



**THE GRID CODE
FOR THE
NIGERIA ELECTRICITY TRANSMISSION
SYSTEM**

GRID CODE

INDEX

CHAPTER 1: GENERAL CONDITIONS	7
1. SECTION: BACKGROUND	7
1.1. Title	7
1.2. New Arrangement for the Nigerian Electricity supply industry	7
1.3. The Grid Code	7
1.4. Application of the Grid Code	7
1.5. Role of the TCN	8
2. SECTION: ORGANISATION AND OBJECTIVES	9
2.1. Objective	9
2.2. Unforeseen circumstances	9
2.3. Enforcement	10
2.4. Definitions	10
2.5. Interpretation	10
2.6. Derogations	11
2.7. Hierarchy	13
2.8. Data and Notices	14
2.9. Effectiveness	14
3. SECTION: REVIEW PROCESS AND CODE DISPUTES	15
3.1. Review Panel	15
3.2. Amendments to grid code	15
3.3. Disputes on the grid code	15
4. SECTION: MONITORING, TESTING AND INVESTIGATIONS	17
4.1. General	17
4.2. Monitoring	17
4.3. Testing	18
4.4. Investigations	19
4.5. Consequences of Monitoring, Testing and Investigations	19
CHAPTER 2: PLANNING	20
5. SECTION: OBJECTIVES, PURPOSE AND SCOPE	20
5.1. Objectives	20
5.2. Purpose	20
5.3. Scope	21
6. SECTION: LOAD FORECAST	21
6.1. Objective	21
6.2. Long term Demand Forecast	22
7. SECTION: EXPANSION PLANNING	22
7.1. Planning standards	22

7.2.	<i>Long Term Expansion Plan</i>	22
7.3.	<i>User involvement</i>	24
8.	SECTION: DATA REQUIREMENTS FOR LONG TERM PLANNING	26
8.1.	<i>Information Required</i>	26
8.2.	<i>Standard Planning Data</i>	27
8.3.	<i>Generating Unit Data</i>	32
8.4.	<i>Demand and Active Energy Data</i>	35
8.5.	<i>Detailed Planning Data</i>	36
8.6.	<i>Transient Over-voltage Assessment Data</i>	41
8.7.	<i>User's Protection Data</i>	41
8.8.	<i>Network Data</i>	44
	CHAPTER 3: CONNECTION CONDITIONS	45
9.	SECTION: PURPOSE AND SCOPE	45
9.1.	<i>Objective</i>	45
9.2.	<i>Purpose</i>	45
9.3.	<i>Scope</i>	46
10.	SECTION: TRANSMISSION SYSTEM PERFORMANCE CHARACTERISTICS	47
10.1.	<i>Frequency and Voltage</i>	47
10.2.	<i>Voltage Perturbations</i>	48
11.	SECTION: CONNECTION PROCESS	50
11.1.	<i>Application for connection</i>	50
11.2.	<i>Process of the application</i>	52
11.3.	<i>Grid Connection Agreement</i>	54
12.	SECTION: TECHNICAL CRITERIA FOR PLANT AND APPARATUS AT THE CONNECTION POINT	56
12.1.	<i>General</i>	56
12.2.	<i>SCADA, Measurement and Data Exchange</i>	56
12.3.	<i>Telecommunication Installations</i>	57
12.4.	<i>Power System control</i>	58
12.5.	<i>Protection Criteria and Metering</i>	58
12.6.	<i>Additional Requirements for Power Stations</i>	59
	CHAPTER 4: OPERATION	79
13.	SECTION: PURPOSE AND SCOPE	79
13.1.	<i>Objective</i>	79
13.2.	<i>Scope</i>	79
14.	SECTION: POWER SYSTEM CONTROL	81
14.1.	<i>Objective</i>	81
14.2.	<i>General</i>	81
14.3.	<i>Power System Control Actions</i>	82
14.4.	<i>Notification to all Users</i>	82
14.5.	<i>Control under fault or emergency conditions</i>	82

14.6.	<i>De-energisation of Plant</i>	83
14.7.	<i>System Operation procedures including Fault Reporting</i>	84
15.	SECTION: FREQUENCY CONTROL AND OPERATING RESERVE	86
15.1.	<i>Objective</i>	86
15.2.	<i>General</i>	86
15.3.	<i>Frequency limits</i>	86
15.4.	<i>Frequency Control</i>	87
15.5.	<i>Components of Operating Reserve</i>	87
15.6.	<i>Operating Reserve Policy</i>	91
15.7.	<i>Amount of Operating Reserve</i>	93
15.8.	<i>Operating Reserve Procurement</i>	93
16.	SECTION: VOLTAGE CONTROL	95
16.1.	<i>Objective</i>	95
16.2.	<i>General</i>	95
16.3.	<i>Voltage Control</i>	95
16.4.	<i>Voltage Control policy</i>	95
16.5.	<i>Voltage Control methods</i>	96
16.6.	<i>Voltage Control during emergencies</i>	96
16.7.	<i>Provision of Voltage control</i>	97
17.	SECTION: BLACK START	99
17.1.	<i>Objective</i>	99
17.2.	<i>General</i>	99
17.3.	<i>Ancillary Service</i>	99
17.4.	<i>Requirements</i>	99
18.	SECTION: EMERGENCY OPERATION AND RESTORATION	101
18.1.	<i>Objective</i>	101
18.2.	<i>General</i>	101
18.3.	<i>Emergency operation</i>	102
18.4.	<i>Restoration of supply</i>	103
18.5.	<i>Back-up Control Centre</i>	104
18.6.	<i>Emergency co-ordination facility</i>	104
18.7.	<i>Under-Frequency Load Shedding</i>	105
19.	SECTION: OPERATIONAL PLANNING	107
19.1.	<i>Objective</i>	107
19.2.	<i>General</i>	107
19.3.	<i>Functions of the Operational Planning staff</i>	108
19.4.	<i>Data required for Medium Term and operational Planning</i>	109
19.5.	<i>Actual Demand Control data</i>	111
19.6.	<i>Connections</i>	111
19.7.	<i>Changes to Information Already Supplied</i>	112

19.8.	<i>Timing and publication</i>	112
20.	SECTION: INFORMATION EXCHANGE	114
20.1.	<i>Objective</i>	114
20.2.	<i>General</i>	114
20.3.	<i>Requirement to notify</i>	114
20.4.	<i>Notification of an Abnormal operation</i>	114
20.5.	<i>Form of notification of an Abnormal operation</i>	115
20.6.	<i>Recording of an Abnormal operation</i>	115
20.7.	<i>Timing in respect of an Abnormal operation</i>	115
20.8.	<i>Notification of events</i>	116
20.9.	<i>Form of notification of an event</i>	116
20.10.	<i>Provision of further information</i>	116
20.11.	<i>Recording of an event</i>	116
20.12.	<i>Timing in respect of an event</i>	116
20.13.	<i>Operational communication and data retention</i>	116
20.14.	<i>Contact locations</i>	117
20.15.	<i>Communication facilities</i>	119
20.16.	<i>Supervisory control and data acquisition (SCADA)</i>	119
20.17.	<i>Computer equipment</i>	120
20.18.	<i>Telephone</i>	120
20.19.	<i>Access and security</i>	120
20.20.	<i>Time standards</i>	121
20.21.	<i>Communication between the Users</i>	121
20.22.	<i>Data and notices</i>	121
20.23.	<i>Data retention</i>	122
21.	SECTION: SCHEDULING AND DISPATCH	123
21.1.	<i>Objective</i>	123
21.2.	<i>General</i>	123
21.3.	<i>Data and Process</i>	124
21.4.	<i>Dispatch Scheduling</i>	124
21.5.	<i>Generation Dispatch</i>	126
22.	SECTION: OUTAGE COORDINATION	133
22.1.	<i>Objective</i>	133
22.2.	<i>General</i>	133
22.3.	<i>Outage scheduling</i>	133
22.4.	<i>Changes to the committed Outage scheduling programME</i>	135
22.5.	<i>Other information to be notified</i>	136
23.	SECTION: RELIABILITY MEASURES	137
23.1.	<i>Objective</i>	137
23.2.	<i>General</i>	137

23.3.	<i>Applicable Reliability Criteria</i>	137
23.4.	<i>Reliability Indicators</i>	137
23.5.	<i>Reporting</i>	138
24.	SECTION: SYSTEM TESTING ON THE NETWORK	139
24.1.	<i>Objective</i>	139
24.2.	<i>General</i>	139
24.3.	<i>Tests Required by TSP or System Operator</i>	139
24.4.	<i>Tests required by User(s)</i>	140
24.5.	<i>Evaluation of Proposed System Tests</i>	141
24.6.	<i>Approval for System Tests</i>	141
24.7.	<i>Scheduling of System Tests</i>	142
24.8.	<i>Dispatching of System Tests</i>	143
24.9.	<i>Test Reporting</i>	143
24.10.	<i>Disputes</i>	144
25.	SECTION: SAFETY AND CO-ORDINATION	145
25.1.	<i>Objective</i>	145
25.2.	<i>General</i>	145
25.3.	<i>Interpretation</i>	145
25.4.	<i>Procedure</i>	146
25.5.	<i>Record of Network Safety Precautions (RNSP)</i>	147
25.6.	<i>Safety Precautions on High Voltage Equipment</i>	148
26.	SIGNIFICANT INCIDENT AND ACCIDENT REPORTING	152
1.	APPENDIX 1: DEFINITIONS	154
2.	APPENDIX 2: CONDITIONS PRECEDENT	175
3.	APPENDIX 3: RELIABILITY CONCEPTS AND DEFINITIONS	176
4.	APPENDIX 4A – RECORD OF NETWORK SAFETY PRECAUTIONS (RNSP)	188
4.	APPENDIX 4B – RECORD OF NETWORK SAFETY PRECAUTIONS	190
4.	APPENDIX 4C – RNSP ISSUE PROCESS	192
4.	APPENDIX 4D – RNSP CANCELLATION PROCESS	193
4.	APPENDIX 4E – RNSP TESTING PROCESS	194
5.	APPENDIX 5 – DATA REGISTRATION REQUIREMENTS	195
6.	APPENDIX 6 - DISTRIBUTION NETWORK DATA	215
7.	APPENDIX 7 – NETWORK EXPANSION PLANNING DATA	219
8.	APPENDIX 8: CIVIL EMERGENCIES	224
9.	APPENDIX 9: GRID CODE REVIEW PANEL	225

CHAPTER 1: GENERAL CONDITIONS

1. SECTION: BACKGROUND

1.1. TITLE

1.1.1. The Grid Code and guidelines shall be called the Grid Code for the Nigeria Electricity Supply Industry (NESI) (henceforth referred to as the “Code”)

1.2. NEW ARRANGEMENT FOR THE NIGERIAN ELECTRICITY SUPPLY INDUSTRY

1.2.1. The Electric Power Sector Reform Act, 2005 (henceforth referred to as the Act) gave legal backing to the unbundling of the Nigeria Power Sector. The Act stipulates the functional unbundling of the Generation, Transmission and Distribution Sectors.

1.2.2. Pursuant to Sections 8, 65 and 66 of the Act, a Transmission and System Operating Company (TCN) shall be established and licenced to perform the functions of transmission and system operations of the High Voltage network of the Nigerian Electricity Supply Industry.

1.3. THE GRID CODE

1.3.1. The Grid Code contains the day-to-day operating procedures and principles governing the development, maintenance and operation of an effective, well-coordinated and economic Transmission System for the Nigerian Electricity Supply Industry.

1.3.2. The code is designed to:

- (a) Facilitate an efficient production and supply of electricity for all Users of the Transmission System and TCN itself, without any act of discrimination between Users or class of Users.
- (b) Facilitate competition in the generation and supply of electricity in the country.

1.3.3. For complete understanding of the operation of the Nigeria Electricity Supply Industry post -deregulation, this document has to be read in conjunction with the Market Rules, Metering Code, Distribution Code and other documents relating to other operational aspects of the industry.

1.4. APPLICATION OF THE GRID CODE

1.4.1. The Grid Code shall apply to TCN and Users of the Transmission System. TCN shall be responsible for implementation of the Grid Code. All Users, the System Operator and the Transmission Service Provider shall comply with the Grid Code and assist TCN in this regard. Users must provide all the required information and reasonable rights of access, service and facilities necessary for implementation of the Grid Code.

-
- (a) If any User has any difficulty in complying with any of the provisions of the Grid Code, the User shall immediately, without delay, inform the same to the Nigerian Electricity Regulatory Commission and TCN, and thereafter shall remedy his non-compliance promptly.
 - (b) Consistent failure in compliance with the Grid Code may lead to disconnection of the User's Plant, Equipment or Apparatus.
 - (c) Consistent failure by the System Operator or the Transmission Service Provider to comply with the Grid Code shall be dealt with under Subsection 4.5.
 - (d) The operation of the Grid Code shall be reviewed regularly by the Grid Code Review Panel in accordance with the provisions of the relevant Sections of the Code.

1.5. ROLE OF THE TCN

1.5.1. TCN shall perform two different groups of functions in relation to network and system operation activities:

- (a) As Transmission Service Provider (TSP):
 - (i) admit Users in accordance with this Grid Code who satisfy the requirements for connection;
 - (ii) evaluate and accept grid connections;
 - (iii) ensure proper metering at all Connection Points;
 - (iv) obtain necessary information from Users of the Transmission Network to enable it to perform adequate planning operations and development of the Transmission Network.
- (b) As System Operator:
 - (i) dispatch Generating Units or Power Park Modules in accordance with this Code at least cost, on the basis of Nominations by Generators;
 - (ii) procure Ancillary Services and recover the costs of procuring Ancillary Services:
 - such procurement may be directly from a Generator or may be via NBET in which case NBET would recover the costs directly from Off-takers;
 - (iii) handle Power System emergencies and restore the Power System;
 - (iv) perform Demand forecasting;
 - (v) coordinate Generation and Transmission Outages;
 - (vi) supervise compliance with, and enforce, the Grid Code;
 - (vii) test and monitor Users' Equipment to ensure their compliance with the Grid Code;

-
- (viii) report scheduled and planned actions and unexpected occurrences such as faults to Users and the Regulator; and
 - (ix) produce procedures for conducting system tests pertaining to the network.

2. SECTION: ORGANISATION AND OBJECTIVES

2.1. OBJECTIVE

2.1.1. The objectives of these General Conditions are:

- (a) To establish the conditions applicable to all the provisions of the Grid Code and to the extent possible, ensure that the provisions of the Grid Code apply for the benefit of the TSP, System Operator and all Users, and for it to apply consistently to all Users.
- (b) To provide the principles and procedures for the development and application of the Grid Code.
- (c) To establish requirements for monitoring, testing and investigation on whether Users are operating within their design, operating and connection requirements, as specified in the Grid Code, Grid Connection Agreements, Ancillary Services Agreements or any other relevant Agreements between Users and the TCN.

2.2. UNFORESEEN CIRCUMSTANCES

2.2.1. The Grid Code contains procedures for the management of day to day technical situations on the Transmission Network, taking into account a wide range of operational conditions likely to be encountered under both normal and abnormal conditions.

2.2.2. The Grid Code cannot predict and address all the possible operating conditions. Users must therefore understand and accept that the TCN, in such unforeseen circumstances, may be required to act decisively to discharge its obligations under its License conditions within the following general principles and priorities:

- (a) Preserve the safety of Equipment, to prevent damage to Plant and/or Apparatus, and public safety to prevent personal injury.
- (b) Preserve or restore the integrity of the Transmission System, including the avoidance of breakdown, separation or collapse (total or partial).
- (c) Compliance by the System Operator with the Electric Power Sector Reform Act, conditions in its System Operator Licence, and the Grid Code.

2.2.3. In case of an unforeseen circumstance that cannot be resolved with the general principles as defined in the previous condition, the System Operator shall act according to the following:

- (a) The application of a policy aimed at equitable sharing amongst Users of any temporary restriction that might be necessary in exceptional circumstances, and

(b) The application of Good Utility Practice.

2.2.4. If circumstances not envisaged by the provisions of the Grid Code should arise, the System Operator shall, to the extent reasonably practicable in the circumstances, consult promptly and in good faith with the Grid Code Review Panel (the Panel) or all affected Users in an effort to reach agreement as to what should be done. If agreement between the System Operator and the Panel or affected Users cannot be reached in the time available, the System Operator shall determine what shall be done in accordance with Good Utility Practice.

2.2.5. The System Operator shall promptly refer any unforeseen circumstance identified, together with the determinations and interpretations made, to the Panel for consideration.

2.2.6. Each User shall comply with all instructions given to it by the System Operator, following a determination of actions regarding an unforeseen circumstance even if there is a difference in interpretation, provided that such instructions are consistent with the technical characteristics of the User's System and the principles established in the Grid Code, and do not endanger the safety of its Equipment or staff.

2.2.7. Users should note that the provisions of the Grid Code may be suspended in whole or in part during a Security Period or in accordance with a Civil Emergency Direction issued under a Civil Emergency directive by an appropriate authority.

2.2.8. Users shall provide such reasonable cooperation and assistance as TCN may require in any such unforeseen circumstances.

2.3. ENFORCEMENT

2.3.1. The Act assigns to NERC the authority to establish the appropriate technical codes and manuals that may be required for the safe, reliable and efficient operation of the System. Within such powers, the NERC has the authority to establish the initial Grid Code and to approve amendments from time to time, as proposed by the TCN and affected Users.

2.3.2. The provisions of this Code shall be enforced by the System Operator in accordance with the Rule 45 of the Market Rules, guidelines from NERC, and Grid Connection Agreements.

2.4. DEFINITIONS

2.4.1. Capitalised words and expressions used in this Code, unless the context otherwise requires, shall have the meaning assigned to them in Appendix 1.

2.4.2. Where a term is not defined in this document it takes the meaning assigned in the Act or the Market Rules with the Act definition taking precedence.

2.5. INTERPRETATION

2.5.1. In this Code, unless the context otherwise requires:

- (a) a reference to a particular Section, Subsection, or Appendix is to a Section or Subsection of, or Appendix to, this Code;

-
- (b) a reference in a particular Section or Appendix to a paragraph is to a paragraph of that Section or Appendix;
 - (c) the table of contents and Section and Subsection headings are for convenience only and shall be ignored in construing this Code;
 - (d) references to the masculine include the feminine and references in the singular include references in the plural;
 - (e) “N” means Naira;
 - (f) the word “include” shall be construed without limitation;
 - (g) a reference to a “person” includes any individual, partnership, firm, company, corporation (statutory or otherwise), joint venture, trust, association, organisation or other entity, in each case whether or not having separate legal personality;
 - (h) a reference to applicable law shall be construed, at the particular time, as including a reference to any modification, extension, re-enactment or replacement thereof then in force;
 - (i) a derivative term of any defined or interpreted term or expression shall be construed in accordance with the relevant definition or interpretation;
 - (j) a reference to another agreement or any deed or other instrument shall be construed as a reference to that other agreement, deed or other instrument, as the same may have been, or may from time to time be, modified; and
 - (k) “in writing” means typewriting, printing, lithography, electronic mail, facsimile and other modes of reproducing words in a legible and non-transitory form.

2.6. DEROGATIONS

2.6.1. If a User finds that it is, or will be, unable to comply with any provision of this Code, then the User shall, without delay, report such non-compliance to the System Operator and shall make such reasonable efforts as are required to remedy such non-compliance as soon as is reasonably practicable.

2.6.2. When the non-compliance described in the Subsection 2.6.1 arises upon the issuance of this Grid Code, or a revision to this Grid Code relating to Equipment already connected to the Transmission System or Equipment approved to be connected to the Transmission System where the User has commenced the procurement or works prior to the issuance of this Grid Code or the revision to this Grid Code, and the User believes either that it would be unreasonable (including on the grounds of cost and technical considerations) to remedy such non-compliance or that it should be granted an extended period to remedy such non-compliance, the User shall promptly submit to the System Operator a request for derogation from such provision in accordance with this Section. The burden of proof shall rest with the User to show good reason why it cannot comply.

2.6.3. If TCN finds that it is, or will be, unable to comply with any provision of this Grid Code, then it shall, without delay, report such non-compliance to the NERC and shall make such reasonable efforts as are required to remedy such non-compliance as soon as is reasonably practicable.

2.6.4. When the non-compliance described in the previous Subsection arises upon the issuance of this Grid Code, or a revision to this Grid Code relating to Equipment already connected to the Transmission System or Equipment approved to be connected to the Transmission System where TCN has commenced the procurement or works prior to the issuance of this Grid Code or the revision to this Grid Code, and TCN believes either that it would be unreasonable (including on the grounds of cost and technical considerations) to remedy such non-compliance or that it should be granted an extended period to remedy such non-compliance, TCN shall promptly submit to the NERC a request for derogation from such provision in accordance with this Section. The burden of proof shall rest with TCN, to show good reason why it cannot comply.

2.6.5. A request for derogation from any provision of this Grid Code shall contain:

- (a) the detail of the Equipment and if relevant Connection Point in respect of which derogation is sought and the nature and extent of non-compliance;
- (b) the provision of this Grid Code with which the TCN or User that requests the derogation is, or will be, unable to comply;
- (c) the reason for the non-compliance; and
- (d) the remedial actions and the date by which compliance could be achieved (if remedy of the non-compliance is possible).

2.6.6. Every six months, the System Operator shall report to the NERC:

- (a) the list of derogations requested during the previous six (6) months, including requests by the TCN, and the status of each request;
- (b) the list of approved derogations during the previous six (6) months indicating type of derogation and party; and
- (c) for each approved derogation, the progress of remedial actions in achieving compliance.

2.6.7. On receipt of any request for derogation, the System Operator or the NERC, as applicable, shall promptly consider such a request provided that the System Operator or the NERC considers that the grounds for the derogation are reasonable. In its consideration of a derogation request, the System Operator or the NERC, as applicable, may contact the User or System Operator, to obtain clarifications of the request or request additional information or to discuss changes to the request, and review possible remedial actions to achieve compliance as soon as reasonably practicable.

2.6.8. The System Operator shall:

-
- (a) keep a register of all derogations which have been granted, identifying the name of the User in respect of whom the derogation has been granted, the relevant provision of this Grid Code and the period of the derogation; and
 - (b) on request from the NERC or any User, provide a copy of such register of derogations.

2.6.9. The NERC shall:

- (a) keep a register of all derogations that have been granted to the TCN, identifying the relevant provision of this Grid Code and the period of the derogation; and
- (b) on request from any User provide a copy of such register of derogations.

2.6.10. The NERC may initiate on its own initiative or at the request of the System Operator, or in view of a User complaint, a review of any existing derogations, and any derogations under consideration where a relevant and material change in circumstance has occurred.

2.7. HIERARCHY

2.7.1. In the event of any inconsistency between this Grid Code and the Act or the Market Rules, or the license of the TSP or the System Operator or a Licensee that is a User, the Act shall prevail to the extent of such inconsistency.

2.7.2. Nothing in this Grid Code is intended to or shall derogate from any license obligation of a Licensee.

2.7.3. If any provision of this Grid Code should be found to be unlawful or wholly or partially invalid for any reason, the validity of all remaining provisions of this Grid Code shall not be affected.

2.7.4. If part of a provision of this Grid Code is found to be unlawful or invalid but the rest of such provision would remain valid if part of the wording were deleted, the provision shall apply with such minimum modification as may be:

- (a) necessary to make it valid and effective; and
- (b) most closely achieves the result of the original wording but without affecting the meaning or validity of any other provision of this Grid Code.

2.7.5. In the event of any conflict between the provisions of this Grid Code and any contract, agreement or arrangement between TCN and a User, the provisions of this Grid Code shall prevail unless this Grid Code expressly provides otherwise, provided that in the case of Grid Connection Agreements with Users signed prior to the approval of this Grid Code, the conditions in such agreement shall prevail unless:

- (a) the parties agree on amendments to such an agreement: or
- (b) the User registers a non-compliance situation that negatively affects the security of the Transmission System, in which case the User must accept the necessary amendments to ensure full compliance with this Grid Code, except for any derogation.

2.7.6. This Grid Code shall be interpreted so as to avoid, to the extent reasonably possible, findings of inconsistency between this Grid Code and the Market Rules; but where there is such an inconsistency and it relates to financial issues the Market Rules shall prevail and where it relates to engineering issues and/or technical issues this Grid Code shall prevail.

2.8. DATA AND NOTICES

2.8.1. For the purposes of this Code, “Business Day” means a day other than:

- (a) a Saturday or a Sunday; or
- (b) a public holiday in Nigeria;

2.8.2. References to times of the day in these Rules are to official time in Nigeria.

2.8.3. Any notice required to be given by this Grid Code shall be deemed to have been given or received:

- (a) if sent by hand, at the time of delivery;
- (b) if sent by post, from and to any address within Nigeria, four (4) Business Days after posting unless otherwise proven; or
- (c) if sent by facsimile, subject to confirmation of uninterrupted transmission report, or by e-mail, one hour after being sent, provided that any transmission sent after 17:00 hours on any day shall be deemed to have been received at 08:00 hours on the following Business Day unless the contrary is shown to be the case.

2.9. EFFECTIVENESS

2.9.1. The provisions of this Code shall come into effect upon the satisfaction or fulfilment of the events and matters set out or referred to in Appendix 2 (the “Conditions Precedent”), as declared by the Commission.

3. SECTION: REVIEW PROCESS AND CODE DISPUTES

3.1. REVIEW PANEL

3.1.1. A Grid Code Review Panel (GCRP) shall be formed pursuant to Rule 42 of the Market Rules. This Panel shall be in charge of the Grid Code review and amendment.

3.2. AMENDMENTS TO GRID CODE

3.2.1. This Code may be amended in accordance with the provisions of Rule 44 of the Market Rules.

3.3. DISPUTES ON THE GRID CODE

3.3.1. Any Dispute relating to, arising out of or in connection with this Code between:

- (a) a User and the TSP;
- (b) a User and the System Operator;
- (c) a person who applies to be a User and the TSP; and
- (d) between Users,

shall be referred to an Expert as defined in Subsection 3.3.3 below.

3.3.2. In the event that the Dispute cannot be resolved by an Expert it shall be resolved in accordance with the provisions contained in Rule 43 of the Market Rules.

3.3.3. Expert Determination:

- (a) Where this Code provides that any Dispute or other matter shall be referred to an Expert or the parties otherwise so agree the following provisions shall apply:
 - (i) Expert shall be a suitably qualified person with requisite experience jointly appointed by the parties and willing to act. If the parties are unable to agree on the choice of an Expert within 30 days, the Expert shall upon a request in writing by either party, be appointed by NERC.
 - (ii) For a period of 30 days after the appointment of the Expert or such other period as the parties may agree, each party may make such written submissions as it wishes to the Expert and shall simultaneously provide a copy to the other party.
 - (iii) At the end of such 30 day period each party shall have a period of 15 days to make counter-submissions to the Expert (with a copy to the other party) in reply to the other party's written submissions made during the aforementioned 15 day period provided that neither party shall during such 15 day period make any written counter-submission which purports to reply to, raise or refer to, any new matters not raised or referred to in any submission made during the aforementioned 15 day period.

-
- (iv) At the end of the 15 day period referred to in Subsection (iii) above, and no later than 15 days thereafter, either party may, with the consent of the Expert and at a time and place decided by the Expert, make an oral presentation to the Expert in the presence of the other party commenting on or explaining matters previously submitted to the Expert in writing.
 - (v) The Expert shall render his determination in writing within 30 days of the completion of the oral presentations made in accordance with Subsection (iv) and give reasonable details of the reasons for his determination.
 - (vi) The decision of the Expert shall be final and binding on the parties save in the event of fraud or manifest error or mistake.
 - (vii) The Expert shall act as an expert and not as an arbitrator.
 - (viii) The costs of the Expert shall be borne as determined by the Expert or, in the absence of such determination, equally by the parties.
 - (ix) Neither party shall have any right to commence or maintain any legal proceedings pertaining to a Dispute until the Dispute has been resolved in accordance with Subsections (i), (ii) or (v) above, and then only to enforce or execute the award under such procedure.
 - (x) The parties shall each secure that all Experts and arbitrators shall agree to be bound by the provisions on confidentiality of this Code as a condition of appointment.

4. SECTION: MONITORING, TESTING AND INVESTIGATIONS

4.1. GENERAL

4.1.1. The System Operator or the TSP, as applicable, will need to carry out certain monitoring, testing and investigations in respect of the performance and characteristics of Generation and Load Plant in order to discharge its responsibilities in respect of the safe, secure and economic operation of the Transmission System and in respect of Generation Dispatch.

4.1.2. In order to achieve the primary objectives, procedures need to be established for the monitoring, testing and investigation for each of the following:

- (a) Whether centrally Dispatched Generating Units or Power Park Modules comply with Dispatch Instructions;
- (b) Whether Generators are in compliance with registered Availability, Ancillary Services capabilities, operating characteristics and any other data required to be registered by those Generators;
- (c) Whether power quality of Users conforms to the standards and limits agreed upon between the affected parties, with respect to the minimum and maximum fault levels, harmonic current injected limits, harmonic voltage contributions, short-term and long-term voltage Flicker, voltage unbalance, the number and the duration and severity of voltage depressions;
- (d) Whether Users are in compliance with protection requirements and protection settings, Grid Connection Agreements, Ancillary Services Agreements and other relevant support agreements between Users and the System Operator or the TSP, as applicable; and
- (e) Whether Service Providers are in compliance with protection requirements and protection settings, Grid Connection Agreements, Ancillary Services Agreements and other relevant support agreements between Users and the System Operator or the TSP, as reasonably applicable.

4.2. MONITORING

4.2.1. Time

Monitoring may be carried out at any time by the System Operator or TSP, as applicable, and may result, without the application of further testing, in the evaluation by the System Operator or TSP of User non-compliance.

4.2.2. Period

Monitoring may be continuous for a specified or unspecified period and shall be carried out by monitoring, data recording and analysis. It shall not require advance notice from the System Operator or TSP to User.

4.2.3. Recording and analysis system

Where a data recording and analysis system is used, the System Operator shall inform the User that this is so and describe any instrument being used. On request from the User, the System Operator shall make available to the User information in respect of the data recording and analysis system.

4.2.4. Disputes

Disputes shall be handled according to Subsection 3.3 above.

4.2.5. Performance parameters

Performance parameters shall be defined according to Rule 12 of the Market Rules.

4.2.6. Monitoring systems and procedures

The systems and procedures shall be laid out as defined in this Code.

4.3. TESTING

4.3.1. System Operator's or TSP's right to testing

System Operator or TSP may, from time to time, carry out tests to verify that a User is complying with its connection conditions and registered operating characteristics in the Registered Information. Such testing by the System Operator and/or TSP should be done in such way as to minimize risk to personnel, Generating Unit and grid integrity.

The System Operator may:

- (a) Induce controlled Power System Frequency or voltage conditions or variations for the purpose of determining that the Generating Unit's or Power Park Module's response is in accordance with its registered Availability, Ancillary Service capabilities and operating characteristics, and
- (b) Having given three (3) Business Days notice, or less where agreed, send a representative to the User's site to verify by testing in accordance with the test procedures specified, that the User is in compliance with its registered values.
- (c) Initiate an unscheduled Compliance Audit at any time in agreement with NERC if reasonably determined to be necessary to ensure the Registered Entities' compliance with the Grid Code and / or Good Utility Practice.

4.3.2. Dispatch Instruction

Tests shall be carried out to a Dispatch Instruction from the System Operator.

A test may require the User to carry out specific actions in response to a Dispatch Instruction.

In particular in order to test the Generating Units or Power Park Module Availability the System Operator may instruct it to operate at full load and if it is shut down instruct it to start and then operate at full load.

4.3.3. Site attendance

A System Operator or TSP representative shall be allowed at User sites in order to carry out tests in accordance with agreed or generic testing procedures.

4.3.4. Results

The results of a test may be derived from the monitoring of performance during the test.

4.3.5. Subcontracting of testing work

If the System Operator or TSP subcontracts testing work on a User's site, then the User and the System Operator or TSP shall be in agreement on the selection of a suitable subcontractor.

4.3.6. Confidentiality

Confidentiality shall be adhered to in accordance with the Market Rules or the Grid Connection Agreement as applicable.

4.4. INVESTIGATIONS

4.4.1. Refer to Market Rules 45.2 for details on investigations.

4.5. CONSEQUENCES OF MONITORING, TESTING AND INVESTIGATIONS

4.5.1. Enforcement

4.5.2. Refer to Market Rules 45 for issues surrounding enforcement of these Subsections.

4.5.3. Payment

4.5.4. Payment for any costs associated with testing will be in accordance with the Market Rules.

CHAPTER 2: PLANNING

5. SECTION: OBJECTIVES, PURPOSE AND SCOPE

5.1. OBJECTIVES

5.1.1. The objectives of this Planning Chapter are:

- (a) To provide guidelines and address the requirements for the System Operator to perform long-term expansion planning of the Nigeria Transmission System.
- (b) To specify the conditions and guidelines for the Users to provide information to the TSP or the System Operator in order that planning and development of the Nigeria Transmission Network can be undertaken in accordance with relevant standards.
- (c) To specify standards which will be used in the planning and development of the Nigeria Transmission Network.
- (d) To specify the information required by the System Operator from Users in respect of:
 - (i) capability of gas-fired generating units to run using alternative fuels; and
 - (ii) mothballed generating Plants.
- (e) To promote interaction between TSP and Users in respect of any proposed development on the network or on a User's System that might impact on the performance of the Nigeria Transmission Network or interconnection to the network.

5.2. PURPOSE

5.2.1. The Transmission System expansion planning will cater for the connection of new Load/Generation to the Transmission System. It will ensure that the impact of these connections can be handled by the existing Transmission System or, if not, it will identify the need for required expansion. The planning and development of the Transmission System shall be in accordance with the Transmission Planning Criteria and relevant standards applicable in Nigeria.

5.2.2. Reasons for development: The development of the Transmission System, involving its reinforcement or extension, will occur for a number of reasons including, but not limited to:

- (a) A development on a User's System (e.g. a Distribution Company) already connected to the Transmission System;
- (b) The introduction of a new substation or the modification of an existing substation between a User's System and the Transmission System;

-
- (c) Changing requirements for electricity transmission facilities due to changes in factors such as Demand, Generation, technology, Reliability requirements, and/or environmental requirements; and
 - (d) A combination of more than one of the above-mentioned developments.

5.2.3. Work involved: The reinforcement or extension of the Transmission System may involve works:

- (a) At a new or existing substation where the User's Plant and/or Apparatus is connected to the Transmission System;
- (b) On new or existing Transmission lines or other facilities which join that substation to the remainder of the Transmission System; and
- (c) On new or existing Transmission lines or other facilities at or between points remote from that substation.

5.2.4. Timing: The time required for the planning and development of the Transmission System will depend on the type and extent of the necessary reinforcement and/or extension work. The time required for obtaining planning permission and wayleaves, including any associated hearings, and the degree of complexity in undertaking the new work while maintaining satisfactory security and Quality of Supply on the existing Transmission System. Actual implementation should be scheduled in advance and coordinated with Users in accordance with Section 19 (Operational Planning) to minimize the impact and risk to the Transmission System and User's Plant.

5.3. SCOPE

5.3.1. This Planning Chapter applies to the System Operator, TSP and to Users of the Transmission System which in this Part of the Code are:

- (a) Generators;
- (b) Distributors;
- (c) Interconnected parties; and
- (d) Directly Connected Customers.

6. SECTION: LOAD FORECAST

6.1. OBJECTIVE

6.1.1. The objective of this Section is to specify the Generation and Demand Forecasts that the System Operator has to generate for short, medium and long term planning expansion purposes.

6.2. LONG TERM DEMAND FORECAST

6.2.1. Timing and publication: System Operator shall create a new long term (20 years) Demand Forecast for the Transmission Network, at least once every 3 years.

This long term Demand Forecast, shall be updated yearly given the actual Demand in the previous year, and shall form part of the report on long term expansion planning to be supplied to the Commission pursuant to Subsection 7.2.7

6.2.2. Demand Forecasts factors: The System Operator shall take the following factors into account when conducting long term Demand Forecasting:

- (a) Historical Demand data;
- (b) Current and anticipated future land use;
- (c) Population and demographic forecasts;
- (d) Economic growth rates;
- (e) Technological development as it potentially impacts Demand; and
- (f) Other information supplied by Users.

6.2.3. Demand Forecast methodology: System Operator shall use a geographical based Demand Forecast methodology based on the factors in Subsection 6.2.2 to produce unbiased forecasts of the Transmission Network Demand into the future.

The methodology shall allow System Operator to perform sensitivity analysis to determine an optimistic, realistic or pessimistic long term Demand Forecast.

7. SECTION: EXPANSION PLANNING

7.1. PLANNING STANDARDS

7.1.1. Transmission Planning Criteria: The System Operator, in consultation with the TSP shall develop comprehensive Transmission Planning Criteria to guide the expansion planning of the Transmission System. The Transmission Planning Criteria shall be approved by the Commission.

7.1.2. The System Operator shall apply the Transmission Planning Criteria and relevant standards in the planning and development of the Transmission System.

7.2. LONG TERM EXPANSION PLAN

7.2.1. Long term Demand Forecast

The System Operator shall use the long term (20 years) Demand Forecast for the Transmission System, pursuant to Subsection 6.2, as input for long term expansion planning.

7.2.2. Refurbishment

The TSP in consultation with System Operator shall perform refurbishment audits on the existing Transmission System in order to determine the remaining useful life of the Transmission System components.

The TSP shall produce a refurbishment plan to replace ageing and damaged Equipment. Such plan shall take into consideration security of the Transmission System and the impact of such activities on Users.

7.2.3. Analyse current network

The System Operator shall analyse and document the current Transmission System adequacy.

7.2.4. Expansion alternatives

The System Operator in collaboration with the TSP shall hold workshops with stakeholders to determine possible alternatives to address the combination of the following inputs:

- (a) Long term Demand Forecast;
- (b) Refurbishment needs; and
- (c) Current Transmission System performance.

7.2.5. Analyse alternatives

The System Operator in collaboration with the TSP shall evaluate the alternatives determined pursuant to Subsection 7.2.4 for at least five, ten, fifteen and twenty years into the future. At least the following analysis shall be performed:

- (a) Load flow analysis;
- (b) Fault level calculations;
- (c) Stability studies;
- (d) Reliability studies; and
- (e) Financial analysis.

7.2.6. Based on the analysis performed pursuant to Subsection 7.2.5 the System Operator shall develop a financially feasible least cost expansion plan, which meets the approved Transmission Planning Criteria.

7.2.7. Long-term expansion plan report

The System Operator shall document the long-term twenty year expansion plan in a report every year. This report shall include at least the following sections:

- (a) Long-term Demand Forecast;
- (b) Long-term Generation Adequacy Forecast (as required under the Market Rules);
- (c) Long-term Transmission Network Adequacy Forecast;
- (d) Long-term zonal Supply and Demand Margin;

-
- (e) Long-term Statutory outage plan for transmission infrastructure;
 - (f) Long-term Refurbishment plan;
 - (g) Alternatives (Identification and Analysis);
 - (h) Capital investment programme; and
 - (i) Financial motivation.

The Commission shall circulate this report to all Users for comments. The Commission will approve the long-term expansion plan once it is satisfied that the System Operator has taken all relevant comments into account.

7.2.8. Approval

The TSP shall be committed to implement the projects listed in the long-term expansion plan (and only these projects) after the Commission has approved the report.

7.3. USER INVOLVEMENT

7.3.1. User's data

The System Operator shall require Users to provide data and information as detailed in Appendixes 6 and 7 on a regular basis, in order for the System Operator in conjunction with the TSP to undertake the planning and development of the Transmission System in accordance with international standards. Information received for this purpose shall be treated as Transmission System planning data.

7.3.2. Additional data

The System Operator or the TSP shall require additional data or information from a User when the System Operator considers it necessary. The User shall submit the information to the System Operator without delay. Such information may be required so that the System Operator and/or TSP can:

- (a) Plan and develop the Transmission System in accordance with the relevant standards
- (b) Monitor Power System performance and predict Power System performance
- (c) Fulfil its statutory or regulatory obligations.

7.3.3. Plant modification

In planning for the development of the Transmission System, the System Operator or the TSP may require an individual User or group of Users, to modify or install new Plant or Apparatus, where the System Operator can reasonably show that it is prudent or necessary to do so. If the work is to be a significant benefit to the User(s), the expenses shall be borne by the User(s) otherwise by the TSP.

7.3.4. Objection

The User(s) may object on grounds that to modify or install new Plant or Apparatus as required, in accordance with Good Utility Practice, would be technically or financially

infeasible. This may include, but shall not be limited to, for example, the installation of Power System Stabilisers. Such objection shall be dealt with under the terms of the User's Grid Connection Agreement.

7.3.5. Closing down

The User shall give the System Operator at least a 24-calendar-month notice if the User plans for any Generating Unit or Power Park Module with registered capacity greater than 10 MW:

- (a) to close down, retire or withdraw it from service; or
- (b) to cease to maintain and keep it available.

The TSP shall give the System Operator at least a 24-calendar-month notice if the TSP intends to remove any transmission circuit or transformer.

8. SECTION: DATA REQUIREMENTS FOR LONG TERM PLANNING

8.1. INFORMATION REQUIRED

8.1.1. In order to develop the Long Term Expansion Plan, the System Operator shall use the guidelines and data requirements indicated in Appendices 5, 6, 7 to specify the technical, design criteria and procedures to be applied in the planning and development of the Nigeria Transmission Network. This information shall be taken into account by Users, when planning and developing their own Plant and Equipment connected to the network.

8.1.2. For Network Planning, User information required as stipulated in Appendices 5, 6, 7 includes data on:

- (a) Standard Planning Data
- (b) Detailed Planning Data
- (c) Network Planning data (Forecast and Registered)
- (d) Connection Planning Data

8.1.3. Standard Planning Data:

This is the data a User, whether already connected or seeking such connection to the Transmission Network, shall provide the TSP of its Plant or Equipment at the Connection Site, which may have impact on the performance of the Nigeria Electricity Network. In addition each Embedded Generating Unit or Power Park Module with capacity greater than 1.0MW connected to the Distribution Network shall provide the TSP with fault infeed data as specified in this Code.

User shall provide the TSP a Single Line Diagram, depicting both its existing and proposed arrangement(s) of load current carrying Equipment relating to both existing and proposed Connection Points that can impact on the Network performance.

8.1.4. Detailed Planning Data:

These are additional detailed data, where it may apply, of the Users Plant and Equipment required by the TSP to conduct further studies if the Users Plant and Equipment might have serious impact on the Transmission Network or existing Users already connected to the Network before allowing the User to connect to the Network. This data must be provided within 30 Business Days after request.

8.1.5. Network Planning Data:

The data required in this category is in Appendix 7.

8.1.6. Connection Planning Data:

The Grid Code requires that at the time the TSP signs a Grid Connection Agreement with the User, estimated values assumed in the Standard Planning Data for planning purposes are confirmed or where practicable replaced by validated actual values. This

data is then termed Connection Planning Data. Connection Planning Data is divided into:

- (a) Forecast Data – items in the Standard Planning and Detailed Planning Data that will always be forecast data.
- (b) Registered Data – items in the Standard Planning and Detailed Planning Data which upon connection to the network become fixed (subject to any subsequent changes).

Connection Planning Data and other relevant Data held by the TSP when a new application is made shall form the background against which such application shall be considered and against which planning for the entire network will be based. With the exception of other data, Users Registered Data shall be treated as non-confidential.

8.2. STANDARD PLANNING DATA

8.2.1. User's System Layout

Users connected or seeking connection to the Transmission Network shall provide Single Line Diagram, depicting both its existing and proposed arrangement(s) of load current carrying Equipment relating to both existing and proposed Connection Points. The Single Line Diagram to be supplied is in addition to the operational diagram.

The Single Line Diagram must include all parts of the User System operating at Transmission and Subtransmission Voltages at the Connection Site. Such diagram must include all parts of the User's Subtransmission System operating at voltages greater than 20kV which under either intact Network or Planned Outage conditions:

- (a) normally interconnects separate Connection Points, or busbars at a Connection Point which normally run in separate sections; or
- (b) connects Embedded Generating Units or Power Park Modules connected to the User's Subtransmission System to a Connection Point.

The Single Line Diagram should also contain additional details of the User's Subtransmission System not already included above and also details of the bulk power transformers connecting the User's Subtransmission System to a lower voltage, plus points at which demand Data and fault infeed data are supplied.

8.2.2. The Single Line Diagram shall include:

Electrical circuitry (i.e. overhead lines, identifying which circuits are on the same towers, underground cables, power transformers, reactive compensation Equipment and similar Equipment); and

- (a) Substation names (in full or abbreviated form) with Operating Voltages
- (b) Circuit breakers
- (c) Phasing arrangements

For each circuit shown on the Single Line Diagram, each User shall provide the following details relating to that part of its Users System:

Circuit Parameters:

- Rated voltage (kV)
- Operating voltage (kV)
- Positive phase sequence reactance
- Positive phase sequence resistance
- Positive phase sequence susceptance
- Zero phase sequence reactance (both self and mutual)
- Zero phase sequence resistance (both self and mutual)
- Zero phase sequence susceptance (both self and mutual)

For each transformer shown in the Single Line Diagram, User shall provide the following:

- Rated MVA
- Voltage Ratio
- Winding arrangement
- Positive sequence reactance (max, min, nominal tap)
- Positive sequence resistance (max, min, nominal tap)
- Zero sequence reactance

In addition for all interconnecting bulk transformers between the User's Transmission Voltage System and the User's Subtransmission System, the User shall supply the following

- Tap changer range
- Tap changer step size
- Tap changer type: on load or off circuit
- Earthing method: direct, resistance or reactance
- Impedance (if not directly earthed)

User shall supply the following about the User's Equipment installed at a Transmission Site:

- Switchgear: For all circuit breakers:-
 - Rated voltage (kV)

-
- Operating voltage (kV)
 - Rated 3-phase rms short-circuit breaking current (kA)
 - Rated 1-phase rms short-circuit breaking current (kA)
 - Rated 3-phase peak short-circuit making current (kA)
 - Rated 1-phase peak short-circuit making current (kA)
 - Rated rms continuous current (A)
 - DC time constant applied at testing of asymmetrical breaking abilities (rms)

- Substation Infrastructure

(This includes but not limited to load switches, isolators, current transformers, line traps, busbars, through bushings etc.)

- Rated 3-phase rms short-circuit withstand current (kA)
- Rated 1-phase rms short-circuit withstand current (kA)
- Rated 3-phase peak short-circuit withstand current (kA)
- Rated 1-phase peak short-circuit withstand current (kA)
- Rated rms continuous current (A)

- Lumped System Susceptance

For all parts of the User's Subtransmission System which are not included in the Single Line Diagram, each User shall provide the equivalent lumped shunt susceptance at nominal Frequency. This should include shunt reactors connected to cables which are not normally in or out of service independent of the cable (i.e. they are regarded as part of the cable), but not including independently switched reactive compensation Equipment connected to the User's System, or any susceptance of the User's System inherent in the Demand (Reactive Power) data specified under this Code.

- Reactive Compensation Equipment

For all independently switched reactive compensation Equipment including that shown in the Single Line Diagram, not operated by TCN and connected to the User's System at 11kV and above, the following information is required:

- Type of Equipment (fixed or variable)
- Capacitive and/or inductive rating or its operating range in MVar
- Details of any automatic control logic to enable operating characteristics to be determined
- The Connection Point to the User's System in terms of electrical location and network voltage.

8.2.3. Short Circuit Contribution to the TSP Transmission Network

(a) General

To allow the TSP and System Operator to calculate fault currents, each User is required to provide data, calculated in accordance with best international practice as set out in this Code.

The data should be provided from the User's System with all Generating Units or Power Park Modules (including all Power Park Units) Synchronised to that User's System. The User must ensure that the pre-fault network conditions reflect a credible System operating arrangement.

The list of data items required, in whole or part under the following provisions is set out in Subsection 8.2.4. The fault currents in sub-paragraphs (a) and (b) of the data list in Subsection 8.2.4 should be based on an AC load flow that takes into account any pre-fault current flow across the Connection Point being considered.

Where prospective short-circuit currents on Equipment owned, operated or managed by the TSP are close to the Equipment rating, and in TSP or System Operator's reasonable opinion more accurate calculations of the prospective short circuit currents are required, then the TSP may request additional short circuit data.

(b) Data from Directly Connected Customers

Directly Connected Customers at each Node on the Single Line Diagram provided to the TSP shall provide motor Loads and/or Embedded Generating Units or Power Park Units and other installations of direct current converters which do not form a DC converter Station assuming a fault at that location, as follows:-

The data items listed under the following parts of 8.2.4

- (a) (i), (ii), (iii), (iv), (v) and (vi)

And the data items shall be provided in accordance to detailed provisions of 8.2.4 (c)–(f).

(c) Data from User's Generating Unit / Power Park Module in a Power Station

For each Generating Unit or Power Park Module in a User's Power Station, with one or more associated Unit Transformer(s), the User is required to provide values for the contribution of the Power Station Auxiliaries (including Auxiliary Gas Turbine or Auxiliary Diesel Engines) to the fault current flowing through the Unit Transformer(s). The data items listed under the following parts of 8.2.4 (a) should be provided:-

- (i), (ii) and (v)

(iii) if the associated Generating Unit / Power Park Module step-up transformer can supply zero phase sequence current from the Generating Unit / Power Park Module side to the Transmission Network

- (iv) if the value is not 1.0 p.u.

The data item shall be provided in accordance with the provisions of 8.2.4(c)–(f).

Auxiliary motor short circuit contribution and any Auxiliary Gas Turbine Unit contribution through the Unit Transformers must be represented as a combined short circuit current contribution at the Generating Unit's terminals or Power Park Module Connection Point, assuming a fault at that location.

If the User's Power Station has separate Station Transformers, data should be provided for the fault current contribution from each transformer at its high voltage terminals, assuming a fault at that location as follows:-

The data items listed under the following parts of 8.2.4 (a) (i) to (vi)

And the data items shall be provided in accordance with the detailed provisions of 8.2.4 (b)-(f)

Data for the fault infeeds through both Unit and Station Transformers shall be provided for the normal running arrangement when the maximum number of Generating Units or Power Park Units are Synchronised to the Network. Where there is an alternative running arrangement which can give higher fault infeed through the Station Transformers, then a separate data submission representing this condition shall be made.

No account should be taken of the interconnection between the Station and Unit Board, unless the normal operating arrangement within the Power Station is to have the Station and Unit Boards interconnected within the Power Stations.

Auxiliary motor short circuit current contribution through the Station Transformers must be represented as a combined short circuit contribution through the Station Transformers.

8.2.4. Data Items

- (a) Below is the list of data utilised in this part of the Planning Chapter. It also contains rules on the data which generally apply:-
- (i) Root mean square of the symmetrical three-phase short circuit current infeed at the instant of fault (I_1'').
 - (ii) Root mean square of the symmetrical three-phase short circuit current after the subtransient fault current contribution has substantially decayed (I_1').
 - (iii) The zero sequence source resistance and reactance values of the User's Equipment as seen from Node on the Single Line Diagram provided under 8.2.1 (or Station Transformer high voltage terminals or Generating Unit terminals as appropriate) consistent with the infeed described in 8.2.1
 - (iv) Root mean square of the pre-fault voltage at which the maximum fault currents were calculated;
 - (v) The positive sequence X/R ratio at the instant of fault
 - (vi) The negative sequence resistance and reactance values of the User's Generating unit seen from Node on the Single Line Diagram provided under 8.2.1 (or Station Transformer high voltage terminals or Generating Unit

terminals, if appropriate) if substantially different from the values of positive sequence resistance and reactance which would be derived from the data provided above.

- (b) In considering this data, unless the User notifies TCN accordingly at the time of data submission, TCN will assume that the time constant of decay of the subtransient fault current corresponding to the change from I_1'' to I_1' (T'') is not significantly different from 40ms. The User must inform TCN if the assumption is not correct in relation to an item of data.
- (c) The value for X/R ratio must reflect the rate of decay of the d.c. component that may be present in the fault current and hence that of the sources of the initial fault current. All shunt elements and loads must therefore be deleted from any System model before the X/R ratio is calculated.
- (d) In producing the data, the User may use “time step analysis” or “fixed-point-in-time analysis” with different impedances.
- (e) If a fixed-in-time analysis with different impedances method is used, then in relation to the data submitted under (a) (i) above, the data will be required for “time zero” to give I_1'' . The figure of 120ms is consistent with a decay time constant T'' of 40ms, and if that figure is different, then the figure of 120ms must be changed accordingly.
- (f) Where a “time step analysis” is carried out, the X/R ratio may be calculated directly from the rate of the d.c. component. The X/R ratio is not that given by the phase angle of the fault current if this is based on a System calculation with shunt loads, but from the Thevenin equivalent of the System impedance at the instant of fault with all non-source shunts removed.

8.3. GENERATING UNIT DATA

8.3.1. Directly Connected Generating Unit

Each Generator with an existing, or proposed Power Station directly connected, or to be directly connected, to the Nigeria Transmission System, shall provide the TSP with data relating to that Power Station both current and forecast as specified in Subsections 8.3.2 to 8.3.3.

On receipt of this data, the Generator may be further required by the TSP or System Operator to provide details of Embedded Generating Unit data.

Where Generating Units which term includes CCGT Units are connected to the Transmission Network via a busbar arrangement which is or is expected to be operated in separate sections, the section of busbar to which each Generating Unit is connected is to be identified in the submission.

8.3.2. Output Data

Items (a) to (i) listed below shall be supplied by each User for its Generating Units, in accordance with the type of Generating Unit involved:

-
- Power Stations and Generating Units:
Data items 8.3.2 (a) to (h) are required with respect to each Power Station and each Generating Unit of each Power Station.
 - Embedded Generating Units
Data item 8.3.2 (a) is required with respect to each Embedded Generating Unit and Generating Unit.
 - CCGT Units/Modules
Data item 8.3.2 (g) is required with respect to each CCGT unit.
Data item 8.3.2 (a) is required with respect to each CCGT Module.
Data item 8.3.2 (b), (c), (d) and (e) are required with respect to each CCGT Module unless TCN informs relevant User in advance of the submission that it needs the data item with respect to each CCGT Unit. Where any definition utilised or referred to in relation to any of the data items does not reflect CCGT Units, such definition shall be deemed to relate to CCGT Units for the purpose of these data items.
 - Hydro schemes
Data items as listed in Appendix 5 particularly 5B, 5H and 5L.2 are required with respect to each hydro scheme.
 - Power Park Modules
Data items as listed in Appendix 5 in 5J, 5K and 5L are required with respect to each Power Park Module.
 - (a) Data Items: Registered Capacity (MW)
 - (b) Output Usable (MW) on a monthly basis
 - (c) Network Constrained Capacity (MW) which may be placed on the capacity of an Embedded Generating Unit due to Distribution Network Operator's System in which it is embedded. Where the Embedded Generating Unit connected to a Distribution Network via a busbar arrangement which is or is expected to be operated in separate sections, details of the busbar arrangements and connected circuits at the substation to which the Embedded Generating Unit is connected must be provided to TCN to determine where the power generated by the Embedded Generating Unit would appear on the Transmission Network.
 - (d) Minimum Generation (MW)
 - (e) MW obtainable from User's Generating Units in excess of Registered Capacity.
 - (f) Generating Unit Capability Chart:
 - (i) at the synchronous Generating Unit stator terminals
 - (ii) at the electrical points of connection to the Transmission Network (or User System if embedded) for a non-synchronous Generating Unit

-
- (g) A list of CCGT Units within a CCGT Module, identifying each CCGT Unit and the CCGT Module of which it forms part, this must be unambiguous in the case of a Range CCGT Module:
 - (i) details of the possible other CCGT Module configurations should also be submitted,
 - (ii) for each case details of the single Grid Connection Point at which power is provided from the Range CCGT Module shall be submitted,
 - (iii) these requirements apply to Embedded Range CCGT Modules.

(Nothing shall prevent the busbar at the relevant point being operated in separate sections)

- (h) Expected running regime(s) at each Power Station and type of Generating Unit (e.g. Steam Unit, Gas Turbine Unit, Combined Cycle Gas Turbine Unit, etc.)
- (i) A list of Power Stations and Generating Units within a cascade hydro scheme, identifying each Generating Unit and Power Station and the cascade hydro scheme of which each form part unambiguously. In addition:
 - (i) details of the Transmission Network Entry Point at which Active Power is provided, or if embedded the Transmission Network Supply points within which the Generating Unit is Connected.
 - (ii) where the Active Power output of a User Generating Unit is split between more than one Transmission Network Supply Point the percentage that would appear under normal and Outage conditions at each Transmission Network Supply point.

Without prejudice to paragraph (g) above, identification of CCGT Units within a CCGT Module can only be amended in accordance with the following provision:

If the CCGT Module is a Normal or Range CCGT Module, the CCGT Units within that Module can only be amended if TCN gives its prior consent in writing. At least 6 months notice of desire to amend the CCGT Units within such CCGT Module must be given before the amendment can take effect.

8.3.3. Rated Parameter Data

The following information is required to facilitate an early assessment of the need for more detailed studies:

- (a) For all User's Generating Units – Rated MVA, Rated MW
- (b) For each synchronous Generating Unit:
 - (i) Short circuit ratio
 - (ii) Direct axis transient reactance
 - (iii) Inertia constant for whole machine, MWsecs/MVA
- (c) For each synchronous Generating Unit step-up transformer:

-
- (i) Rated MVA
 - (ii) Positive sequence reactance (at max, min and nominal tap)

8.4. DEMAND AND ACTIVE ENERGY DATA

8.4.1. Introduction

Each User directly connected to the Transmission Network with Demand shall provide TCN with Demand data – historic, current and forecast, as specified in this Code, which applies equally to Active Energy requirements and to Demand unless the context otherwise requires.

Data will need to be supplied by

- (a) Users, in relation to Demand and Active Energy requirements on the User's System
- (b) Directly Connected Customer in relation to its Demand and Active Energy requirements

8.4.2. Active Power and Energy Data

Forecast daily Demand (Active Power) profiles as specified in (a), (b) and (c) below, in respect of each of the User's Systems (each summed over the Transmission Network Supply Points in each User System) are required for:

Peak day on each of the User's Systems giving the numerical value of the maximum Demand (Active Power) that in the Users' opinion could reasonably be imposed on the Transmission Network.

- (a) Day of peak Demand on the Transmission Network (Active Power) as notified by System Operator.
- (b) Day of minimum Demand on the Transmission Network (Active Power) as notified by System Operator.
- (c) In addition, the total Demand (Active Power) in respect of the time of peak of the Transmission Network Demand in the preceding year for each of the User's Systems summed over the Transmission Network Supply points, for actual and weather corrected values shall be supplied.

8.4.3. In order that Users can provide the above data the SO shall by calendar week 20, inform Users of the Transmission Network in writing of the following, for the current year and each of the subsequent 5 years, which will apply until replaced by the following year's notification:

- (a) The date and time of the annual peak of the Transmission Network Demand.
- (b) The date and time of the annual minimum of the Transmission Network Demand.

-
- (c) Total Active Demand used on each of the grid Supply Points in the preceding year, together with a prediction of the current financial year, is required.

8.4.4. Each Active Energy submission required in Subsection 8.4.2 shall be subdivided into the following categories of Customer tariff:

- (i) Domestic customers
- (ii) Commercial customers
- (iii) Industrial customers
- (iv) Customers connected at 33kV and above
- (v) Traction
- (vi) Street lighting and special customers

In addition, the total User losses and Active Energy provided by Embedded Generating Units shall be supplied.

8.5. DETAILED PLANNING DATA

8.5.1. Introduction

- (a) Directly Connected

Each User with existing Power Station(s) directly connected or to be directly connected to TCN network shall provide TCN with data relating to the Plant and Equipment, both current and forecast as in Subsection 8.5.2 as applicable.

- (b) Embedded

Users with existing or proposed Embedded Generating Unit(s) or Power Park Module(s) shall provide TSP with data relating to the Embedded Generating Unit(s) or Power Park Module(s) both current and forecast.

- (c) Demand

For each User's Generating Unit or Power Park Module which has an associated Unit Transformer, the value of the Demand supplied through this Unit Transformer when the Generating Unit or Power Park Module is at Rated MW output is to be provided.

Where the Power Station has associated Demand additional to the unit supplied Demand which is supplied from either the Transmission Network or the Generator's User's Equipment the Generator User shall supply forecasts for each Power Station of:

The maximum Demand that in the User's opinion could reasonably be imported from grid network or the Generator's User Equipment as appropriate;

- (i) The Demand at the time of peak TCN Network Demand;
- (ii) The Demand at the time of minimum TCN Network Demand.

In order that Users can provide the above data, the SO shall by calendar week 20, inform Users of the Transmission Network in writing of the following, for the current year and each of the subsequent 5 years, which will apply until replaced by the following year's notification:

- (iii) The date and time of the annual peak of the Transmission Network Demand
- (iv) The date and time of the annual minimum of the Transmission Network Demand

8.5.2. Synchronous Generating Unit and associated control system data

The following synchronous Generating Unit and Power Station data should be supplied

- (a) synchronous Generating Unit Parameters
 - (i) Rated terminal volts (kV)
 - (ii) Rated MVA
 - (iii) Rated MW
 - (iv) Minimum generation MW
 - (v) Short circuit ratio
 - (vi) Direct axis synchronous reactance
 - (vii) Direct axis transient reactance
 - (viii) Direct axis sub-transient reactance
 - (ix) Direct axis short-circuit transient time constant
 - (x) Quadrature axis synchronous reactance
 - (xi) Quadrature axis sub-transient reactance
 - (xii) Quadrature axis short-circuit sub-transient time constant
 - (xiii) Stator time constant
 - (xiv) Stator leakage reactance
 - (xv) Armature winding direct-current resistance
 - (xvi) Turbogenerator inertia constant (MWsec/MVA)
 - (xvii) Rated field current (amps) at rated MW, rated MVA_r export and at rated terminal voltage
 - (xviii) Field current (amps) open circuit saturation curve for Generating Unit terminal voltages ranging from 50% to 120% of rated value in 10% steps as derived from appropriate manufacturer's test certificates.
- (b) Parameters for Generating Unit Step-up Transformer(s)
 - (i) Rated MVA

-
- (ii) Voltage ratio
 - (iii) Positive sequence reactance (at max, min & nominal tap)
 - (iv) Positive sequence resistance (at max, min & nominal tap)
 - (v) Zero phase sequence reactance
 - (vi) Tap changer range
 - (vii) Tap changer step size
 - (viii) Tap changer type-on load or off load
- (c) Excitation control system parameters
- (i) Excitation Equipment nominal response
 - (ii) Rated field voltage
 - (iii) No-load field voltage
 - (iv) Excitation Equipment on-load positive ceiling voltage
 - (v) Excitation Equipment no-load positive ceiling voltage
 - (vi) Excitation Equipment no-load negative ceiling voltage
 - (vii) Details of excitation Equipment described in block diagram form showing transfer functions of individual elements
 - (viii) Details of over-excitation limiter described in block diagram form showing transfer functions of individual elements
 - (ix) Details of under-excitation limiter described in block diagram form showing transfer functions of individual elements
- (d) Governor parameters
- (i) Incremental droop values (in %) are required for each Generating Unit at six MW loading points (MLP1 to MLP6).
 - (ii) Governor and associated prime mover parameters – All Generating Units
 - Governor Block diagram showing transfer function of individual elements including acceleration sensitive elements
 - Governor time constant (in seconds)
 - Speeder motor setting range (%)
 - Average gain (MW/Hz)
 - Governor deadband – maximum setting (+/- Hz), normal setting (+/- Hz), minimum setting (+/- Hz)
(where the Generating Unit governor does not have a selectable deadband facility, then the actual value of the deadband need only be provided)

-
- (iii) Governor and associated prime mover parameters (Steam Units):
 - HP valve time constant (in seconds)
 - HP valve opening limits (%)
 - HP valve opening rate limits (% /second)
 - HP valve closing rate limits (%/second)
 - HP turbine time constant (in seconds)
 - IP valve time constant (in seconds)
 - IP valve opening limits (%)
 - IP valve opening rate limits (% /second)
 - IP valve closing rate limits (%/second)
 - IP turbine time constant (in seconds)
 - LP valve time constant (in seconds)
 - LP valve opening limits (%)
 - LP valve opening rate limits (% /second)
 - LP valve closing rate limits (%/second)
 - LP turbine time constant (in seconds)
 - (iv) Governor and associated prime mover parameters (Gas Turbine Units):
 - Inlet guide vane time constant (in seconds)
 - Inlet guide vane opening limits (%)
 - Inlet guide vane opening rate limits (%/second)
 - Inlet guide vane closing rate limits (% /second)
 - Fuel valve constant (in seconds)
 - Fuel valve opening limits (%)
 - Fuel valve opening rates limits (%/second)
 - Fuel valve closing rate limits (%/second)
 - (v) Governor and associated prime mover parameters – hydro Generating Units
 - Guide vane actuator time constant (in seconds)
 - Guide vane opening limits (%)
 - Guide vane opening rate limits (%/second)
 - Guide vane closing rate limits (%/second)
 - Water time constant (in seconds)

-
- (vi) Unit control options
 - Maximum droop %
 - Normal droop %
 - Minimum droop %
 - Maximum Frequency deadband +/- Hz
 - Normal Frequency deadband +/- Hz
 - Minimum Frequency deadband +/- Hz
 - Maximum output deadband +/-MW
 - Normal output deadband +/-MW
 - Minimum output deadband +/-MW
 - (vii) Frequency settings between which Unit load controller droop applies:
 - Maximum Hz
 - Normal Hz
 - Minimum Hz
 - (viii) Plant Flexibility Performance
 - Run-up rate to registered capacity
 - Run-down rate from registered capacity
 - Synchronising generation
 - Regulating range
 - Load rejection capability while still Synchronised and able to supply Load.
 - (ix) Response data for Frequency changes

Prior to the Generating Unit being first Synchronised, the MW loading points must take the following values:

 - MLP1 Designed minimum operating level
 - MLP2 Minimum generation
 - MLP3 70% of Registered Capacity
 - MLP4 80% of Registered Capacity
 - MLP5 95% of Registered Capacity
 - MLP6 Registered Capacity
 - (x) Primary and Secondary Response to Frequency Fall

Primary and Secondary Response values for a -0.5Hz step are required at six MW Loading Points (MLP1 to MLP6) as detailed above.

-
- (xi) High Frequency Response to Frequency Rise

High Frequency Response valves for a +0.5Hz step are required at six MW loading points (MLP1 to MLP6)

8.5.3. Power Park Module and Associated Control System Data

The data required for Power Park Modules is broadly in line with those of synchronous machines with some technology specific modifications. The User should submit the specific Power Park Module data as detailed in Appendix 5 in particular Sections 5J, 5K and 5L.

8.6. TRANSIENT OVER-VOLTAGE ASSESSMENT DATA

8.6.1. Each User is required to provide the following data with respect to the Connection Site, current and forecast, together with a Single Line Diagram if not already provided:

- (a) Busbar layout plan(s), including dimension and geometry showing positioning of any current and voltage transformer, through bushings, support insulators, isolators, circuit breakers, surge arrestor etc. Electrical parameters of any associated current and voltage transformer, stray capacitance, off wall bushings and support insulators, and giving capacitances of circuit breakers;
- (b) Electrical parameters and physical construction details of lines and cables connected at the busbar. Electrical parameters of all Plant (e.g. transformers-including neutral earthing impedance or zigzag transformers if any), series reactors and shunt compensation Equipment connected at that busbar (or to the tertiary of a transformer) or by lines or cables to the busbar;
- (c) Basic insulation levels of all Equipment connected directly by lines or by cables to the busbar;
- (d) Fault levels at the lower voltage terminals of each transformer connected directly or indirectly to the TSP Network without intermediate transformation; and
- (e) All transformers operating at 132kV and over, three or five limb cores or single phase units to be specified and operating peak flux density at nominal voltage.

8.7. USER'S PROTECTION DATA

8.7.1. Protection

The following information is required, which relates only to protection Equipment which can trip or inter-trip or close any Connection Point circuit breaker or any TCN circuit breaker. This information need to be supplied once and regular updates made afterwards:

-
- (a) Full description, including estimated settings, for all relays and protection systems installed or to be installed on the User's System;
 - (b) Full description of auto-reclose facilities installed or to be installed on the User's System, including type and time delays;
 - (c) Full description, including estimated settings, for all relays and Protection systems installed or to be installed on the Generating Unit, Generating Unit transformer, station transformer and their associated connections;
 - (d) Generating Units having (or intended to have) a circuit breaker at the generator terminal voltage, clearance times for electrical faults within the Generating Unit zone; and/or
 - (e) Most probable fault clearance time for electrical faults on any part of the User's System directly connected to TCN Network.

8.7.2. Harmonic Studies

In the course of operating the Transmission Network, the System Operator or the TSP will have to evaluate the occurrence of harmonic distortion on the Network or User's Systems, especially when Equipment like capacitor banks is involved. For proper evaluation, in respect of the Connection Site, Users are required to submit current and forecast data if not already submitted under 8.2 for any Subtransmission System for overhead and underground cable circuits:

- Positive phase sequence resistance
- Positive phase sequence reactance
- Positive phase sequence susceptance

For transformers connecting the User's Subtransmission System to a lower voltage:

- Rated MVA
- Voltage Ratio
- Positive phase sequence resistance
- Positive phase sequence reactance

And at the lower voltage points of those connecting transformers:

- Equivalent positive phase sequence susceptance
- Connection voltage and MVA_r rating of any capacitor bank and component parameters if designed as a filter
- Equivalent positive phase sequence interconnection impedance with other lower voltage points
- The minimum and maximum Demand (both MW and MVA_r) that could occur
- Harmonic current injection sources in Amps at the Connection voltage points

-
- Details of traction Load (e.g. connection phase pairs, continuous variation with time etc.)
 - An indication of which items of Equipment may be out of service simultaneously during planned Outage condition

8.7.3. Voltage Assessment Studies

In the course of operating the Transmission Network, the System Operator will have to undertake voltage assessment studies on the Network to examine potential voltage instability, Voltage Control co-ordination or calculate voltage step changes. Users are required, to submit current and forecast data if not already submitted under Subsection 8.2 for any Subtransmission System for overhead and underground cable circuits:

(a) For User's Subtransmission System:

- Positive phase sequence resistance
- Positive phase sequence reactance
- Positive phase sequence susceptance
- MVA_r rating of any reactive compensation Equipment

(b) For bulk transformers connecting the User's Subtransmission System to a lower voltage:

- Rated MVA
- Voltage Ratio
- Positive phase sequence resistance
- Positive phase sequence reactance
- Tap-changer range
- Number of tap steps
- Tap-changer type: on-load or off-circuit
- AVC/tap-changer time delay to first tap movement
- AVC/tap-changer inter-tap time delay

(c) And at the lower voltage points of those connecting transformers:

- Equivalent positive phase sequence susceptance
- MVA_r rating of any reactive compensation Equipment
- Equivalent positive phase sequence interconnection impedance with other lower voltage points
- Maximum demand (MW, MVA_r) that could occur.

8.8. NETWORK DATA

8.8.1. If a User wants to model the Transmission Network, the TSP shall provide the Network data indicated in Subsection 8.8.2 to allow the User properly calculate conditions on the Network.

8.8.2. Single and Multiple Point Connection

The TSP, or System Operator as applicable, shall provide User with the following data:

- (a) Symmetrical three phase short circuit current infeed at the instant of fault from the Transmission System (I_1'')
- (b) Symmetrical three phase short circuit current from the Transmission System after the subtransient fault current contribution has substantially decayed (I_1')
- (c) Zero sequence source resistance and reactance values at the Connection Point, consistent with the maximum infeed
- (d) Pre-fault voltage magnitude at which the maximum fault currents were calculated
- (e) Positive sequence X/R ratio at the instant of fault
- (f) Negative sequence resistance and reactance values of the Transmission System seen from the Connection Point
- (g) Initial positive sequence resistance and reactance values of the two or more sources and the linking impedances derived from a fault study constituting the π equivalent and evaluated without the User network and load
- (h) Corresponding zero sequence impedance values of the π equivalent
- (i) The TSP or System Operator, as applicable, shall provide additional reasonable and relevant information as requested by User.

The positive sequence X/R ratio and zero sequence impedance will correspond to the Transmission Network only.

CHAPTER 3: CONNECTION CONDITIONS

9. SECTION: PURPOSE AND SCOPE

9.1. OBJECTIVE

9.1.1. This Connection Conditions Chapter specifies the minimum technical, design and certain operational criteria which must be complied with by the Users connected to, or seeking connection to the Transmission Network. They also set out the Procedure by which the Transmission Service Provider (TSP) will process an application for connection to the Transmission System, seeking to ensure compliance with these criteria as a requirement for the granting of approval for the connection of a User to the Transmission System.

9.1.2. The provisions of the Connection Conditions shall apply to all connections to the Transmission Network:

- (a) existing at the date when this Grid Code comes into effect;
- (b) existing at the date of commencement of the TSP's approval, where these dates precede the date in (a) above; and
- (c) as established or modified thereafter.

9.1.3. The Connection Conditions are designed to ensure that:

- (a) No new or modified connection will impose unacceptable effects upon the Transmission System or on any User network nor will it be subject itself to unacceptable effects by its connection to the Transmission System.
- (b) The basic rules for connection treat all Users within an equivalent category in a non-discriminatory fashion.

9.2. PURPOSE

9.2.1. The purpose of this Connection Conditions is:

- (a) to specify the technical, design, and operational criteria at each Connection Point;
- (b) to ensure that there is no undue discrimination in the application of the Grid Code between Users or classes of User;
- (c) to facilitate the use of the Transmission System by any User connected to or seeking connection to the Transmission System, in accordance with a Grid Connection Agreement;
- (d) to define the requirements for a User seeking connection and/or for a modification of the current connection; and
- (e) to enable the TCN to develop, maintain and operate the Transmission System in a coordinated and economic manner in compliance with its licence.

9.3. SCOPE

9.3.1. The Connection Conditions apply to the System Operator, TSP and to Users of the Transmission System which in this Connection Conditions are:

- (a) Generators;
- (b) Distributors;
- (c) Interconnected parties;
- (d) Directly Connected Customers.

10. SECTION: TRANSMISSION SYSTEM PERFORMANCE CHARACTERISTICS

10.1. FREQUENCY AND VOLTAGE

10.1.1. In order to maintain the security and integrity of the Transmission System, it is necessary that the System Operator operates the Transmission System and Dispatches it in such a manner as to provide adequate Frequency Control to achieve operation within applicable Frequency limits at all times.

10.1.2. The nominal Frequency of the System shall be 50Hz. The National Control Centre will endeavour to control the System Frequency within a narrow operating band of +/- 0.5% from 50Hz (49.75 – 50.25 Hz), but under System Stress the Frequency on the Power System could experience variations within the limits of 50 Hz +/- 2.5% (48.75 – 51.25 Hz).

10.1.3. All Equipment and Apparatus connected directly or indirectly to the National Grid must operate at 50Hz Frequency mode.

10.1.4. Under extreme System fault conditions all Generating Units or Power Park Modules are permitted to disconnect (unless otherwise agreed in writing with the System Operator):

- (a) at a Frequency greater than or equal to 51.50 Hz, provided that for frequency excursions up to 51.75Hz of no more than 15 seconds it shall remain synchronised with the system; or
- (b) at a Frequency less than or equal to 47.5 Hz.

10.1.5. The System Operator shall endeavour to control the different busbar voltages to be within the Voltage Control ranges specified in Table 1:

Voltage level	Minimum Voltage kV (pu)	Maximum Voltage kV (pu)
330 kV	280.5 (0.85)	346.5 (1.05)
132 kV	112.2 (0.85)	145.2 (1.10)
66 kV	62.04 (0.94)	69.96 (1.06)
33 kV	31.02 (0.94)	34.98 (1.06)
11 kV	10.45 (0.95)	11.55 (1.05)

Table 1: Voltage Control ranges

Under System Stress or following System faults, voltages can be expected to deviate outside the above limits by a further +/-5% (excluding transient and sub-transient disturbances).

10.1.6. Due to the effect of travelling waves on the Transmission Network as a result of atmospheric disturbances or the switching of long transmission lines, transient over-voltage can occur at certain Node points of the network. The insulation level of all Apparatus must be coordinated to take account of transient over-voltages and sensitive User Equipment, such as computer and other solid state Equipment, which should be suitably isolated from this effect.

10.1.7. The transient over-voltage during lightning strikes is typically experienced over a voltage range of $\pm 20\%$ of nominal voltage. Connection Points close to a network lightning strike will experience voltages higher than this.

10.1.8. Unless otherwise agreed by the TSP, the basic insulation value (BIL) for User Apparatus shall be as follows:

- (a) For the 330 kV System, the BIL is 1050 kV.
- (b) For the 132 kV System, the BIL is 650 kV.

10.2. VOLTAGE PERTURBATIONS

10.2.1. “Voltage Flicker” is a rapid change in voltage that is typically caused by User Equipment that distorts or interferes with the normal sinusoidal voltage waveform of the Transmission System. Such interference is a product of a relatively large current inrush when Apparatus, such as a large motor, is suddenly switched on, or resulting from the sudden increased demand from for example welding Equipment. Such distortions can disturb Users Equipment and cause, for instance through flickering lights, consumer annoyance. The current inrush acting over the network impedance is the mechanism that produces the voltage dip (sudden fall) and the corresponding voltage swell (sudden rise) when the Apparatus concerned is offloaded. Hence, it is the cause of the “Voltage Flicker”.

10.2.2. Users are required to minimise the occurrence of Voltage Flicker on the Transmission System as measured at the User’s Connection Point. The Flicker Severity at the Connection Point of any User shall not be above the maximum values stated in IEC 61000-3 Standard for more than 3 % of the period. The maximum emission limits produced by any User shall be below the maximum values stated in IEC 61000-3 Standard.

10.2.3. In cases where, in the reasonable opinion of the System Operator, variations in generation or demand constitute a risk to Transmission System operation, strict conformity with the IEC 61000-3-7 flicker curve will be required.

10.2.4. Harmonics are normally produced by User’s Apparatus generating waveforms that distort the fundamental 50 Hz wave. Such harmonic generation can damage User Apparatus and can result in failure of Transmission System Apparatus. The limits for harmonic distortion levels are given in the following documents:

- (a) EN 50160:2010 “Voltage characteristics of electricity supplied by public distribution Systems”.
- (b) IEC/TR3 61000-3-6 ed2.0 (2008) “Assessment of emission limits for distorting loads in MV and HV Power Systems”.

10.2.5. In general, the maximum total levels of harmonic distortion on the System under Normal Operation conditions, planned outages and fault outage conditions (unless during System Stress) shall not exceed following values:

- (a) 330 kV a Total Harmonic Distortion of 1.5% with no individual harmonic greater than 1%
- (b) 132 kV a Total Harmonic Distortion of 2% with no individual harmonic greater than 1.5%.

10.2.6. Under Normal Operation, the maximum negative phase sequence component of the phase voltage of the Transmission System should remain below 1%.

10.2.7. Under planned outage conditions, infrequent short duration peaks with a maximum value of 2% are permitted for phase unbalance.

11. SECTION: CONNECTION PROCESS

11.1. APPLICATION FOR CONNECTION

11.1.1. **Application:** Users proposing a connection to the Transmission System, either through a new substation, a modification of an existing substation, or in an existing substation shall send an application to the TSP. If this demand for new connection falls outside the approved Regulatory Long Term Transmission Plan, the cost for such works shall be borne by the User.

11.1.2. **Application information:** Users shall submit the application on an application form for a connection to the Transmission System. Amongst other information, the application form shall include:

- (a) A description of the Plant or Apparatus to be connected to the Transmission System or, the modification relating to the User's Plant or Apparatus already connected to the Transmission System
- (b) Confirmation that the User's Plant and Apparatus at the Connection Point will meet the required technical standards in this Grid Code, as agreed with the TSP where appropriate.
- (c) Confirmation that User's Plant, Apparatus and Procedures will meet the safety provisions in Section 25.
- (d) The technical data as stipulated in Appendixes 5, 6 anticipated for the User's modified or new Plant or Apparatus, specifying the Load characteristics and other data. The TSP shall compile a standard list of details required from the User; and
- (e) The desired connection date and operational date of the proposed User's development.
- (f) A proposed commissioning schedule, including commissioning tests, for the final approval of the System Operator and the TSP.

11.1.3. **Preliminary planning data:** Data supplied in the application form or data submitted along with the application form that is directly relevant to the application and has been submitted in support of it shall be treated as preliminary planning data until such time as the offer for a connection has been made and accepted.

11.1.4. To allow adequate time for consideration of the request, the User shall make this application well in advance prior to the proposed connection date, and in any case not less than 3 months before such date. It shall be taken into account that typical time periods required by TCN to undertake the execution of Transmission System expansion projects necessary for a new connection are:

- (a) overhead transmission lines – 18 months; and
- (b) substation – 24 months.

11.1.5. Planning data: Transmission System planning data, together with other data held by the TSP relating to the Transmission System shall form the basis from which new applications by any User shall be considered and from which planning of the Transmission System shall be undertaken. Transmission System planning data shall not be treated as confidential to the extent that the TSP is obliged:

- (a) To use it in the preparation of the forecast;
- (b) To use it when considering and/or advising other Users;
- (c) To use it for the SO planning purposes; and
- (d) Under the terms of a Grid Connection Agreement to pass it on as part of System information on the Power System.

11.1.6. Type of data: Transmission System planning data is divided into the following type of data:

- (a) Which will always be forecast, known as forecast data;
- (b) Which upon connection becomes fixed, known as Registered Information; and
- (c) Which relate to Plant, Equipment or Apparatus for the purposes of the Plant concerned as at the date of submission, known as Registered Information, but which for the ten succeeding years shall be an estimate of what is expected, known as estimated Registered Information.

11.1.7. Actual data: Users shall supply the TSP with all outstanding data as stipulated in Appendixes 6 and 7 not later than the operational date if not previously requested by the TSP. This shall include confirming any estimated values assumed for planning purposes or, where practical, replacing them by validated actual values and by updated estimates for the future and by updating forecasts for forecast data items.

11.1.8. Additional information: The TSP shall request that a User supply additional information, as the TSP deems necessary to verify the accuracy of the data received, if in the opinion of the TSP it is incorrect.

11.1.9. Tests for data verification: The TSP or the System Operator shall request that the User carry out specific tests, at the User's expense, to verify the data, if it maintains that the additional information is insufficient to verify the accuracy of the original. Where such a test or tests are requested, they shall be subject to the provisions of the relevant Section of the Grid Code.

11.1.10. Costs for tests:

- (a) The TSP shall carry all costs incurred as a result of the test or tests in the event that the initial data as submitted by the User is verified by the test or tests to be correct.
- (b) The User shall carry all costs incurred as a result of the test or tests in the event that the data as submitted by the User is verified by the test or tests to be incorrect. If the TSP has to redo or perform additional System studies then the

User shall also bear the costs reasonably incurred as a result of the said additional work.

11.2. PROCESS OF THE APPLICATION

11.2.1. The TSP shall establish a Procedure for the processing of applications for connection or modification of an existing connection to the Transmission System. This shall include the time frames required to process the application and to submit to the User an offer for connection. This Procedure will be approved by the NERC.

11.2.2. System studies: Based on the data supplied by the User, the TSP will coordinate with the System Operator to perform the System impact studies required to evaluate in detail the impact of the proposed User development on the Transmission System (the magnitude and complexity of any Transmission System extension or reinforcement varies according to the nature, location and timing of the proposed User's development).

11.2.3. Users' studies: Upon request of the User, the TSP shall provide to the User adequate and sufficient information regarding the Transmission System, to enable the User to conduct impact studies on the User's System, and/or the Transmission System as it considers appropriate.

11.2.4. Plant parameters: The Users shall provide the TSP with all the relevant Plant or Apparatus parameters as required from Appendixes 5, 6 and 7 before SO shall proceed with the above-mentioned System studies.

11.2.5. During the application for connection process, based on the results of the System Studies, the TSP will agree with the User the voltage level and Connection Point to the Transmission System. The TSP may, eventually, specify a different Connection Point or connection voltage in order to avoid potential disturbance caused by the User's Equipment to other Users of the Transmission System or for other technical reasons, or may agree alternative methods for minimizing the effects of disturbing Loads.

11.2.6. In determining the Connection Point, including the voltage level, the following aspects shall to be taken into consideration:

- (a) No discrimination: In assessing the technical requirements of a User's connection, the TSP shall not unfairly discriminate between Users of a similar category, location or size, although it shall not be technically or economically practicable to achieve uniformity of method of connection at all times.
- (b) Generating Unit voltage level: the Transmission System voltage level and the busbar configuration at which a Generating Unit shall be connected to the Transmission System shall depend upon, but shall not be limited to the following:
 - (i) The size of the Generating Units / Power Park Module(s) and the number of Generating Units / Power Park Unit(s) comprised in the potential User's System, together with a Single Line Diagram of the site showing all main electrical Equipment up to and including the Connection Point;

-
- (ii) Consistency with future development of the Transmission System;
 - (iii) Proximity to the existing Transmission System; and
 - (iv) The cost of the proposed connection.
- (c) Directly Connected Customers voltage level: The Transmission System voltage level at which a Directly Connected Customers shall be connected to the Transmission System shall depend upon, but shall not be limited to the following:
- (i) The size of the Active Power Demand at the Connection Point;
 - (ii) Consistency with future development of the Transmission System;
 - (iii) Proximity to the existing Transmission System; and
 - (iv) The cost of the proposed connection.
- (d) Distribution voltage level: The Transmission System voltage level at which a Distributor shall be connected to the Transmission System shall depend upon but shall not be limited to the following:
- (i) The size of the Active Power Demand at the Connection Point;
 - (ii) Consistency with future development of the Transmission System;
 - (iii) Consistency with coordinated planning of the Transmission System and of the Distribution System;
 - (iv) Proximity to the existing Transmission System; and
 - (v) The cost of the proposed connection.
- (e) Method of connection: The method of connection used may exceed the relevant standards where the User requires it. In this case the TSP shall accept this provided:
- (i) it has no consequent negative impacts on the System or on other Users; and
 - (ii) the User pays all relevant costs associated with this higher standard.

11.2.7. After evaluating the application submitted by the User, the TSP shall inform the User whether the proposed application is acceptable or not. The TSP may disapprove an application for connection or a modification of an existing connection to the Transmission System only if it is determined through System Studies that the proposed connection or modification does not fulfil the technical requirements or results in the degradation of the Transmission System.

11.2.8. If the application of the User is not acceptable:

- (a) The TSP shall notify the User as to why its application is not acceptable.
- (b) The TSP shall include in its notification details of the amendments required to make the User's application acceptable to the TSP.
- (c) The TSP shall immediately report any rejected application to the NERC.

11.2.9. Offer detail: In case the application is accepted, the TSP shall submit to the User an offer to connect to the Transmission System. This Connection Offer shall include, but shall not be limited to the following:

- (a) Details of how the connection shall be made, including details of the Plant and Apparatus that shall be required to implement the connection;
- (b) A description of any modification that the applicant User shall be required to pay for;
- (c) An indication of the connection date and the operational date; and
- (d) An estimate of the charges for connection.

11.2.10. Acceptance of the offer: A connection offer shall provide that the applicant User accepts it within the period stated in the offer, which shall never be less than forty five (45) days, after which the offer shall automatically lapse. Acceptance of the offer shall be effected by execution of the Grid Connection Agreement by both parties, which renders the TSP works relating to that User development committed and shall bind both parties in accordance with its terms. The User shall supply the data pertaining to the User's development within sixty (60) days of acceptance of the connection offer.

11.2.11. Committed planning data: Once a connection offer has been accepted, all data supplied in the application form and any other data submitted along with the application form, shall be treated as committed project planning data.

11.3. GRID CONNECTION AGREEMENT

11.3.1. The acceptance by the User of the TSP proposal shall lead to the signing of a Grid Connection Agreement. If TSP and the User cannot reach agreement on the proposed connection, or modification to an existing connection, the User shall have the right to bring the matter before the NERC for resolution. The NERC shall have reasonable right of access to any information that it deems fit in order to resolve such disagreement.

11.3.2. Before entering into a Grid Connection Agreement and before connecting a User's System at a Connection Point, it will be necessary for the TSP to be reasonably satisfied that the User's System at the boundary with the Transmission System will comply with all appropriate requirements of this Grid Code.

11.3.3. The Grid Connection Agreement is a site specific Agreement between TSP, System Operator and a User of the Transmission Network. The agreement shall cover all technical issues involving connection, energisation and operation of generating units or Power Park Modules connected to the Transmission Network and/or centrally despatched by the System Operator. Amongst other topics, the agreement shall cover the following areas:

- (a) Construction or upgrading of substation and /or Transmission Network
- (b) Connection of Generating Unit / Power Park Module or Equipment to substation and / or Transmission Network

-
- (c) Commissioning and Decommissioning of Generating Units / Power Park Modules or Equipment
 - (d) Commercial and Technical Boundaries
 - (e) Protection, Control and Metering.
 - (f) Ownership boundaries and access
 - (g) Operational diagrams
 - (h) Connection charges.
 - (i) Supplementary Agreements – Use of System, Ancillary Services
 - (j) Emergency operations, Health and Safety.
 - (k) Reporting and recording of incidence at site.
 - (l) Emergency, Force Majeure, Disputes Resolution

11.3.4. The Grid Connection Agreement shall include, and shall not be limited to, provisions for the submission of information and reports, Safety Rules, Test and Commissioning programmes, electrical diagrams, statement of readiness to connect, certificate of approval to connect, and other requirements agreed between the parties.

12. SECTION: TECHNICAL CRITERIA FOR PLANT AND APPARATUS AT THE CONNECTION POINT

12.1. GENERAL

12.1.1. At the Connection Point all User's Plant and Apparatus shall meet acceptable technical design and operational criteria. Detailed information relating to a particular connection will be made available by the TSP on request by the User. Such information will include, but not be limited to, the following:

- (a) Load flow studies.
- (b) Short circuit studies.
- (c) Power System stability analysis.
- (d) Annual/monthly Load curves.
- (e) Line Forced Outage rates, for the network associated with the proposed Connection Point.
- (f) Telecommunications network associated with the proposed Connection Point.

12.1.2. All Plant and Apparatus connected to or proposed for connection to the Transmission System are required to meet relevant current international and pan-European technical standards, such as IEC, ISO, and EN.

- (a) Furthermore, Plant and Apparatus shall be designed, manufactured and tested in accordance with IEC or equivalent approved standard, and quality assurance requirement of ISO 9001 or equivalent.
- (b) The User shall ensure that the specification of Plant and Apparatus at the Connection Point shall be such to permit operation within the applicable safety procedures agreed between the User and SO as required in Section 25.

12.2. SCADA, MEASUREMENT AND DATA EXCHANGE

12.2.1. Technical facilities shall be installed on all interconnecting circuits between different parties' networks and different Control Areas for exchange of the following information to both parties in real time:

- (a) Status indications of circuit breaker, isolator switches, and earth switches
- (b) Measurement of Active and Reactive Power flow, Voltages and Frequency
- (c) Selected protection information.

12.2.2. The above information shall be made available to all Control Centres that have a responsibility to monitor or control the applicable circuits or is affected by the operation thereof.

12.2.3. Requirements: The technical facilities provided shall adhere to the following minimum requirements:

- (a) Double bit status indications measurement;
- (b) Three phase Active Power and Reactive Power measurement;
- (c) Single-phase Voltage measurement; and
- (d) Support open SCADA protocols to allow interface with other vendor's Equipment.

12.2.4. Recording facilities: Transient recording facilities shall be installed on the Interconnecting circuits between different parties' networks. These facilities shall be Synchronised to the Universal Time Coordinated reference time (UTC time).

12.2.5. Power interchange: Each Control Centre responsible for a Control Area shall provide the Facilities to schedule the power interchange with other Control Areas effectively on a frequent and continuous basis.

12.3. TELECOMMUNICATION INSTALLATIONS

12.3.1. Telecommunication facilities at Control Centres: Each Control Centre shall install adequate and reliable telecommunication facilities for their own needs and those of other parties to ensure that the effective exchange of information necessary to maintain the Reliability of the Interconnected network can take place. Wherever possible, there will be back-up facilities and route diversity.

12.3.2. Hot Line: Direct telecommunication channels ("Hot Line") shall be provided between a Control Centre and the Control Centre of each adjacent network, Generators within the Control Area, and co-ordination centres.

12.3.3. Alternative telecommunication channels: Alternative and physically independent telecommunication channels shall be provided to back up the direct circuits, including a Switched Voice Circuit via the Transmission System network, as well as a Switched Voice Circuit via the public telecommunications network where available.

12.3.4. Data communication: Data communication channels shall be provided to support the metering, SCADA, and protection systems. Automated channel monitoring and failure alarms shall be provided for protection communication channels if such failure can cause undesired protection operation.

12.3.5. Voice recording: A voice recording system shall be provided in each Control Centre to record all voice communications between Operators during network operation. The recording of these voice communications should be kept at least 2 months for reference when needed.

12.3.6. Communication system Reliability and Availability: The Reliability and Availability of the communication system(s) shall be of acceptable quality levels and in accordance with the prevailing telecommunication standards.

12.4. POWER SYSTEM CONTROL

12.4.1. Generator installations: Technical facilities must be installed on all Generator networks to provide the following information to the responsible Control Centre:

- (a) Status indications of circuit breaker, isolator switches, and earth switches insofar as they are required for operation of the network
- (b) Measurement of Active and Reactive Power flow in both the import and export directions, as well as Voltages and Frequency
- (c) Where applicable, reference values for control (activation/deactivation of primary/secondary control) and instantaneous Demand value of the secondary control.
- (d) Reference value of the Reactive Power in the form of the schedule or as an instantaneous value (e.g. for Voltage and Reactive Power Control).
- (e) Selected protection information
- (f) Power Park Modules should provide the appropriate signals (as agreed by the System Operator) from the following list:
 - (i) Wind speed (m/s) (for Power Park Modules comprised of wind turbines)
 - (ii) Wind direction (degrees (0 = North)) (for Power Park Modules comprised of wind turbines)
 - (iii) Solar irradiation (W/m^2) (for Power Park Modules comprised of PV modules)
 - (iv) Percent of Plant in operation (%) (for all Power Park Modules)
 - (v) Available power estimation (MW) (for all Power Park Modules)

12.4.2. Generator Control Centre: The Control Centre of each Generator shall provide the facilities to effectively schedule the power interchange with the Control Centre of the Interconnected Network.

12.5. PROTECTION CRITERIA AND METERING

12.5.1. Minimum protection requirements: The minimum requirements for any new and existing connection will vary depending on many factors such as Load type, earthing methods and others. However, the minimum requirements shall encompass three-phase over current, earth fault (to suite earthing requirements); and inter-tripping.

12.5.2. International standards: All protective schemes and systems shall be in accordance with internationally accepted standards, philosophies and performance.

12.5.3. Protection Schemes: Protection Schemes shall be designed for reliable clearing of all network faults in an effective manner and within an acceptable time duration, and shall be secured against unwanted operation for out-of-zone faults, brief overloads, transient surges or power swings.

12.5.4. The requirements for inter-tripping of protection Apparatus at the Connection Point shall be coordinated between the User and the TSP. This shall be specified in the respective Grid Connection Agreement.

12.5.5. Fault Clearance Times: Fault clearance times at the Connection Point and the method of System earthing including, where relevant, the recommended Generating Unit neutral earthing configuration, will be provided by the TSP on request.

Typical fault clearance times for main protection schemes are as follows:

- (a) 60 ms for faults cleared by busbar protection at 330 kV and 132 kV.
- (b) 80 ms for faults cleared by distance protection on 330kV and 132 kV overhead lines.
- (c) 80 ms for faults cleared by transformer protections on HV transformers.

Total fault clearance time shall be from fault inception until the time to arc extinction, which therefore includes relay operation, circuit breaker operation and telecommunications signalling times.

12.5.6. Users will be expected to coordinate their protection times according to the clearance times specified by the TSP. Prospective Users whose proposed protection scheme cannot achieve these times, or whose Power Station cannot continue operations whilst line faults on the Transmission System are cleared, may be required to resubmit their proposals for final approval by the TSP.

12.5.7. Protection philosophy: Each party shall implement the prevailing protection philosophy, standards and preventive maintenance procedures that shall improve their System Reliability with the least adverse effects on the Interconnected Network.

12.5.8. Grading: All protection schemes and all modifications to existing protection schemes that affect the neighbouring System in any way shall be technically coordinated and graded with the other party's System.

12.5.9. Back-up protection: Backup protection facilities shall be provided in accordance with the prevailing protection standards in case of the main protection failing to operate.

12.5.10. Network stability and integrity: High speed relays, high speed circuit breakers and automatic re-closing Facilities shall be used where studies show that their application shall enhance the network Stability. Automatic re-closing under out-of-step conditions shall be prevented by blocking relays.

12.5.11. Under-Frequency Load Shedding relays shall be coordinated to ensure System Stability and integrity.

12.5.12. Metering: Metering installations at the Connection Point shall be designed in accordance with the Metering Code.

12.6. ADDITIONAL REQUIREMENTS FOR POWER STATIONS

Performance Requirements

12.6.1. The Generating Units shall have, at least, following performance requirements:

- (a) Each Generating Unit must be capable of supplying rated power output (MW) at any point between the limits of 0.85 power factor lagging and 0.95 power factor leading, at the Generating Unit terminals at rated Voltage level in the Transmission Network within the Power System Frequency range given in Subsection 10.1.2.
- (b) Each Generating Unit must be capable of continuously supplying its registered output within the Power System Frequency range given in Subsection 10.1.2.
- (c) The Active Power output under steady state conditions of any Generating Unit directly connected to the Transmission Network should not be affected by Voltage changes in the operating range as per Table 1 in Subsection 10.1.5.
- (d) The Reactive Power output of a Generating Unit having a synchronous alternator must, under steady state conditions, be fully available within the Voltage range $\pm 10\%$ of nominal Voltage at the Connection Point.
- (e) A Generating Unit having a synchronous alternator must be capable of start-up, synchronize and pick up load:
 - (i) From cold, within 14 hours.
 - (ii) From warm, within 6 hours.
 - (iii) From hot within 3 hours.
- (f) A steam-turbine or gas-turbine Generating Unit which has been Synchronised must be capable of ramping up pursuant to a Dispatch Instruction at a rate of at least 3% of Registered Capacity per minute. A steam-turbine or gas-turbine Generating Unit must be capable of de-loading at a rate of at least 3% of Registered Capacity per minute.

12.6.2. All Generating Units must be fitted with a turbine controller, which is designed and operated to the requirements of IEC 60045, or equivalent standards. All Generating Units must be fitted with a turbine Governor Control System which must operate on a power related speed droop characteristic of between 4% and 6%.

- (a) Each Generating Unit must be fitted with a fast acting Governor Control System. The turbine speed control principle shall be that the Generating Unit output shall vary with rotational speed according to a proportional droop characteristic (“Primary Control”). Superimposed load control loops shall have no negative impact on the steady state and transient performance of the turbines rotational speed control.
- (b) The Governor Control System shall be sufficiently damped for both isolated and interconnected operation modes. Under all operation conditions, the damping coefficient of the Turbine Speed Control shall be above 0.25 for speed droop settings above 3% for gas turbines and 5% for steam turbines. For Generating Unit oscillations with frequencies below 2 Hz, the Governor

Control System shall have no negative effect on Generating Unit oscillation damping.

- (c) The Governor Control System and any other superimposed control loop (Load control, gas turbine temperature limiting control, etc.) shall contribute to the Primary Control to maintain the unit within the Generating Unit capability limits.
- (d) The Primary Control characteristics shall be maintained under all operational conditions. Additionally, in the event that a Generating Unit becomes isolated from the System but is still supplying Demand the Generating Unit must be able to provide Primary Control to maintain Frequency and Voltage.

12.6.3. A continuous Automatic Voltage Regulator (AVR) acting on the excitation system is required to provide constant terminal Voltage of the Generating Unit without instability over the entire operating range of the Generating Unit. Control performance of the Voltage Control loop shall be such that under isolated operating conditions, the damping coefficient shall be above 0.25 for the entire operating range.

- (a) The Automatic Voltage Regulator (AVR) shall have no negative impact on Generating Unit oscillation damping. If required, the appropriate Power System Stabiliser (PSS) shall be provided. Control principle, parameter setting and switch on/off logic shall be coordinated with the System Operator and specified in the Grid Connection Agreement.

12.6.4. Each Generating Unit shall be required to withstand, without tripping, the negative phase sequence loading experienced during clearance of a close-up phase-to-phase fault by System back-up protection on the Transmission Network.

12.6.5. The System Frequency could rise to 51.5 Hz or up to 51.75Hz for no more than 15 seconds or fall to 47.5 Hz and Generating Units/ Power Park Modules must continue to operate within this Frequency range unless the System Operator has agreed to any Frequency-level relays and/or rate-of-change-of-Frequency relays which shall trip such Generating Units or Power Park Modules within this Frequency range, as stated in the Grid Connection Agreement.

12.6.6. Generators shall be responsible for protecting all their Generating Units and Power Park Modules against damage should System Frequency variations exceed 51.75 Hz or over 51.5 Hz for up to 15 seconds or go below 47.5 Hz or such limits agreed with the System Operator. In the event that such variations occur, the Generator shall disconnect the Generating Unit for reasons of safety of personnel, Apparatus, and/or Plant.

12.6.7. Power Park Module diagram

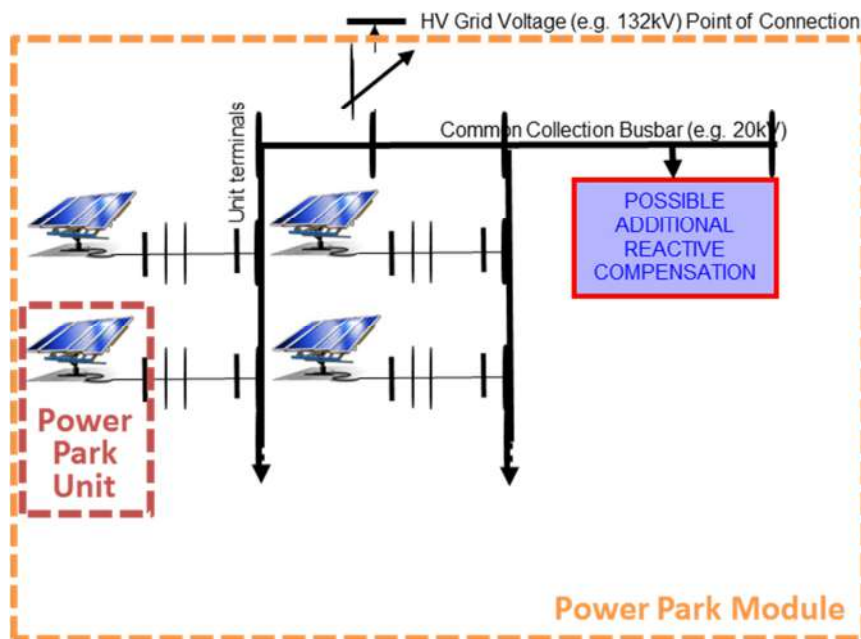

12.6.8. Power Park Module performance requirements during normal Voltage operating range

- (a) Power Park Modules must remain connected for Voltage changes at the Connection Point in the normal operating range as per Table 1 in Subsection 10.1.5.
- (b) The Active Power output under steady state conditions of any Power Park Module should not be affected by Voltage changes in the operating range as per Table 1 in Subsection 10.1.5.

12.6.9. Power Park Module performance requirements during Voltage disturbances

- (a) Power Park Modules shall be designed to withstand Voltage drops and peaks, as illustrated in Figure 1.
- (b) V_{min} and V_{max} in Figure 1 correspond to the appropriate ranges as per Table 1 in Subsection 10.1.5, based on the Connection Point rated Voltage.
- (c) The Power Park Module shall be able to withstand Voltage drops to zero, measured at the Connection Point, for a minimum period of 0.15 seconds without disconnecting, as shown in Figure 1.
- (d) The Power Park Module shall be able to withstand Voltage peaks with a maximum Voltage of up to 120% of the nominal Voltage, measured at the Connection Point, for a minimum period of 2 seconds without disconnecting, as shown in Figure 1.
- (e) Figure 1 shall apply to all types of faults (symmetrical and asymmetrical) and the bold line shall represent the minimum Voltage of all the phases.

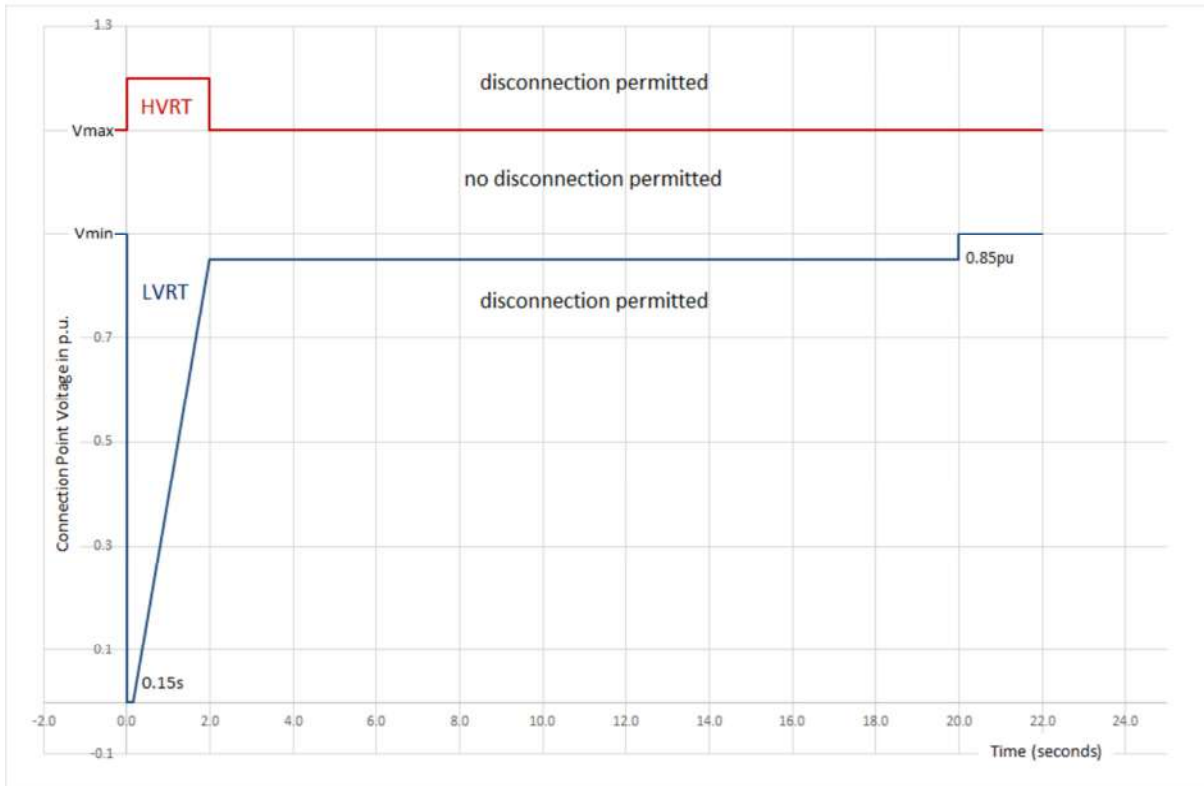

Figure 1: Voltage Fault Ride Through requirement for Power Park Modules

- (f) If the Voltage (V) reverts to the normal operating range (as per Table 1 in Subsection 10.1.5) during a fault sequence, subsequent Voltage drops shall be regarded as a new fault condition. If several successive fault sequences occur and the Voltage remains outside of the normal Voltage operating range, the successive series of faults shall be considered to be one continuing fault condition. In addition, desynchronisation of the Power Station from the TCN Transmission Network will be permitted if the operating point falls below the LVRT line to the ‘desynchronisation permitted’ area or above the HVRT line to the ‘desynchronisation permitted’ area, as illustrated in Figure 1.

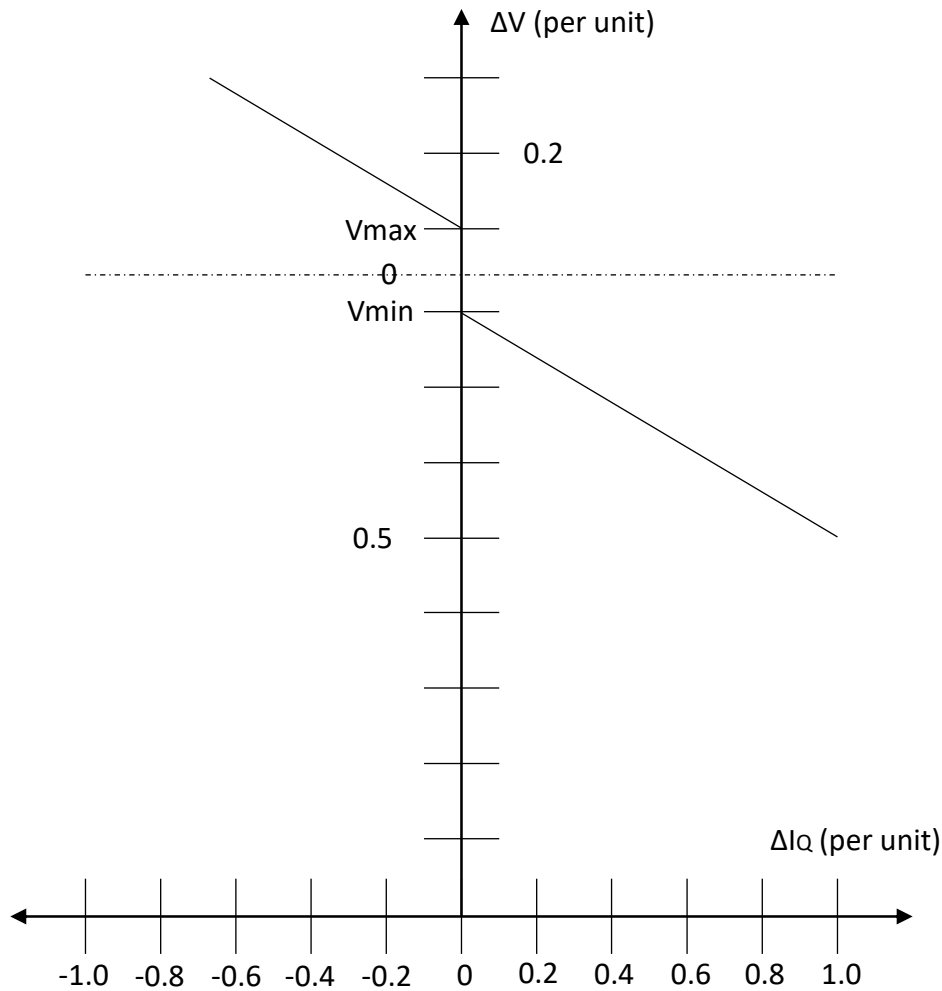

Figure 2: Requirements for Reactive Power support, ΔIQ , during Voltage drops or peaks at the Power Park Unit terminals

12.6.10. Voltage support during grid faults (see Figure 2). Note that due to the timescales involved, this requirement is applied at the Power Park Unit level. Therefore, this Subsection shall also apply at the terminals of any additional dynamic Reactive Power Equipment which may form part of the Power Park Module. This may include, but is not limited to, such Equipment as a SVC or STATCOM.

- (a) The Power Park Unit shall have the capability of delivering an additional reactive current in proportion to the Voltage change ΔV at its terminals, as illustrated in Figure 2.
- (b) V_{min} and V_{max} in Figure 2 correspond to the appropriate ranges as per Table 1 in Subsection 10.1.5, based on the Connection Point rated Voltage but applied to the Power Park Unit terminal Voltage.

-
- (c) The factor of proportionality between additional reactive current and Voltage deviation is named K ($\Delta I_Q = K\Delta V$). The factor K must be settable in the range of $0 < K < 4$.
 - (d) The default setting for the K factor shall be 2 as shown in Figure 2.
 - (e) The additional reactive current ΔI_Q according to Figure 2 shall be injected in addition to the pre-fault reactive current.
 - (f) The Voltage deviation ΔV is defined as being the difference between the pre-fault Voltage and the Voltage during the fault.
 - (g) Both pre-fault current and pre-fault Voltage are defined by the 1-minute average of the positive sequence component of the fundamental frequency value of current and Voltage respectively.
 - (h) The post-fault Voltage on which basis the Voltage deviation ΔV is calculated is the positive sequence component of the Voltage at the Power Park Unit terminals.
 - (i) The additional reactive current shall be injected as a positive sequence component.
 - (j) 60ms after fault inception, the additional current shall remain within a tolerance band of $\pm 20\%$ around the value according to Figure 2.
 - (k) The absolute value of the current in each phase that is injected into the grid can be limited to the rated current of the Power Park Unit.
 - (l) The reactive current requirement applies to retained Voltages (during the fault) greater than 10%. Below 10% the current of the Power Park Unit can be set to zero.
 - (m) As long as the Power Park Unit operates below V_{min} , reactive current will have priority over active current, and active current should therefore be reduced if required to meet the characteristic shown in Figure 2.
 - (n) Upon the termination of a LVRT event, when Voltage is back into the normal operating range as per Table 1 in Subsection 10.1.5, each Power Park Unit shall restore Active Power to it at least 90% of its pre-fault value within 1s.
 - (o) During Voltage recovery, a Power Park Unit must not absorb more Reactive Power than prior to the fault (reference for pre-fault Reactive Power: 1 minute average).

12.6.11. The following points detail the minimum requirements for Reactive Power capability for Power Park Modules:

- (a) A Power Park Module must have the capability of varying Reactive Power at the Connection Point within the reactive capability limits defined by Figure 3 when the Connection Point Voltage is at 1 per unit.

-
- (b) These Reactive Power limits will be reduced pro rata to the amount of Plant in service.
 - (c) The Power Park Module shall be designed in such a way that the operating point can lie anywhere within its maximum and minimum capability according to Figure 3.
 - (d) The Reactive Power capability defined in Figure 3 is modified depending on the Voltage at the Connection Point as per Figure 4. This requirement applies once automatic Tap Changer(s) of the grid transformer(s) and / or any switched shunts in the Power Park Module have operated. In the period(s) that the Automatic Tap Changer is not functional the Power Park Module is required to reduce Active Power export from the Power Park Module so that Reactive Power capability can be provided.
 - (e) For Active Power levels below 5% of rated MW output (point C in Figure 3), there is no Reactive Power capability requirement. In this range, it is required that the Power Park Module operates within the tolerance range specified by point A and point B in Figure 3. Point A is equivalent (in MVar) to -5% of Rated Output and point B is equivalent (in MVar) to 5% of Rated Output. Note that if the Power Park Module can provide full or partial Reactive Power Control capability down to zero Active Power then it may do so without limitation provided that this capability allows operation at zero MVar exchange (unity power factor).
 - (f) Power Park Modules which are comprised of PV inverter modules, and have a Connection Point at 132kV or above, must additionally be designed to deliver the full reactive capability down to zero Active Power or below, including the ability to provide Reactive Power at night time. This mode of operation is sometimes referred to a 'Synchronous Compensation Mode'. For the avoidance of doubt, for Power Park Modules which fall into this category, the clause 12.6.9(e) and the reduction in Reactive Power below 20% shown in Figure 3, does not apply.

12.6.12. For Active Power levels below 5% of rated MW output (point C in Figure 3), there is no Reactive Power capability requirement. In this range, it is required that the Power Park Module operates within the tolerance range specified by point

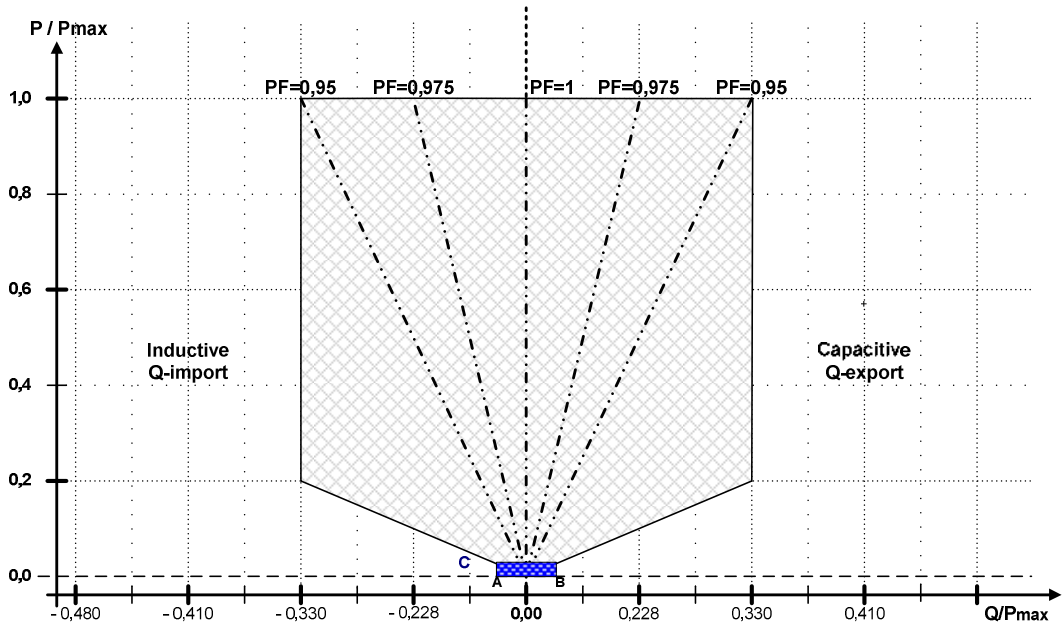

Figure 3: Reactive Power requirements at 1 per unit Voltage at the Connection Point for Power Park Modules

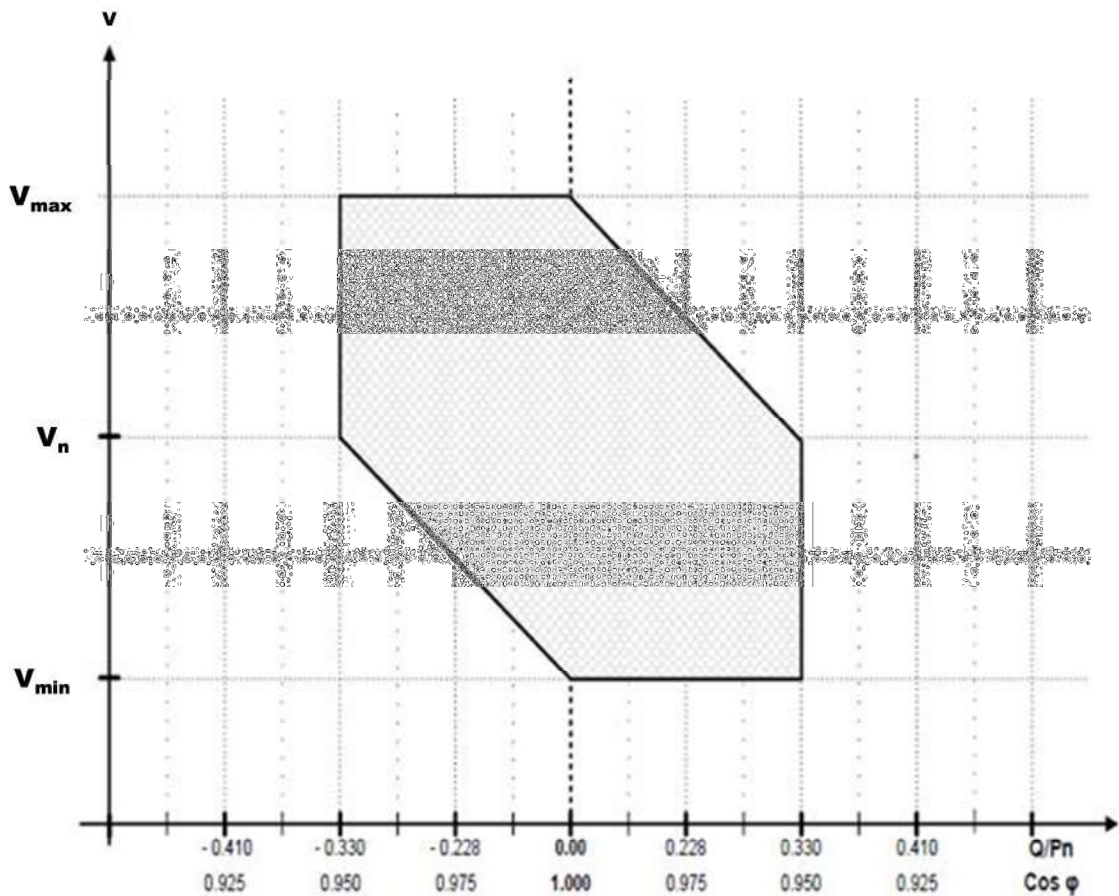

Figure 4: Variation of Reactive Power requirement for different Voltages at the Connection Point for Power Park Modules

12.6.13. Reactive Power Control and Voltage Control Requirements for Power Park Modules:

- (a) The Power Park Module shall be equipped with Reactive Power Control functions capable of controlling the Reactive Power supplied by the Power Park Module at the Connection Point as well as a Voltage Control function capable of contributing to Voltage support at the Connection Point via orders using set-points and gradients.
- (b) The Reactive Power and Voltage Control functions are mutually exclusive, which means that only one of the following three functions can be activated at a time:
 - (i) Voltage Control
 - (ii) Power Factor Control
 - (iii) Reactive Power (Q) Control, including Q(P) Control

-
- (c) The control function and applied parameter settings for Reactive Power and Voltage Control functions shall be determined by the System Operator, and implemented by the Power Park Module Generator. The agreed control functions and initial parameters shall be documented in the Connection Agreement.
- (d) Reactive Power (Q) Control, including Q(P) Control:
- (i) Q control is a control function controlling the Reactive Power supply and absorption at the Connection Point, either independently of the Active Power and the Voltage or in function of Active Power (Q(P) Control). This control function is illustrated in Figure 5 as a vertical, red line (independent of Active Power) or as the green line (in function of Active Power). The indicated Q(P) characteristic is just an example. It is up to the System Operator to define the actual settings of the Q(P) characteristic, however it will always start with unity power factor (0 MVA_r) at low power output.
 - (ii) If the Q control setpoint is to be changed by the System Operator, the Power Park Module shall respond to the new set point within the timescales as detailed in Subsection 21.5 of this Grid Code.
 - (iii) The accuracy of the control performed shall be as per the tolerance values detailed in Subsection 21.5 of this Grid Code.
 - (iv) The Power Park Module shall be able to receive a Q setpoint with a discrimination of at least 1kVA_r.
 - (v) If the operating point of the Power Park Module deviates from the characteristic in Figure 5 the automatic control system should act to restore the operating point onto the characteristic within the following timescales:
 - d.v.1) Response from inverter based Plant should commence within 1 second
 - d.v.2) All transformer and shunt tapping (where applicable) should be completed, and the operating point should be settled onto the characteristic within 2 minutes.

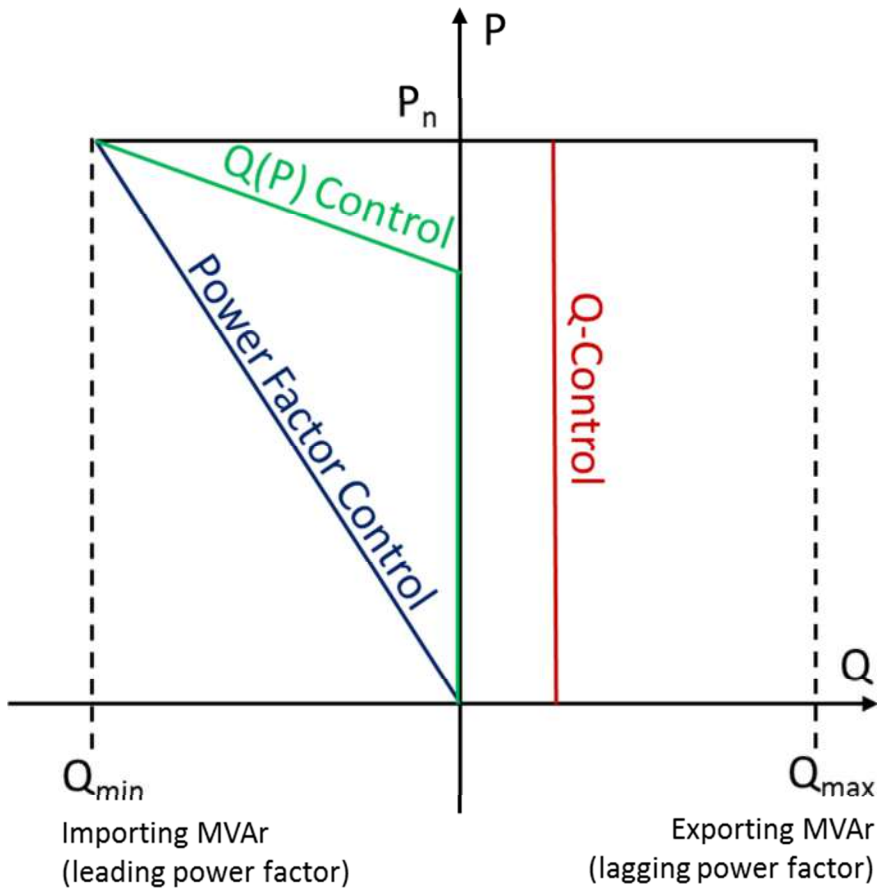

Figure 5: Reactive Power Control functions for the Power Park Module

- (e) Power Factor Control:
 - (i) Power Factor Control is a control function controlling the Reactive Power to maintain a constant power factor at the Connection Point as shown by the blue line in Figure 5.
 - (ii) The Power Park Module shall respond to the new setpoint within the timescales as detailed in Subsection 21.5 of this Grid Code.
 - (iii) The accuracy of the control performed shall be as per the tolerance values detailed in Subsection 21.5 of this Grid Code.
 - (iv) If the operating point of the Power Park Module deviates from the characteristic in Figure 5 the automatic control system should act to restore the operating point onto the characteristic within the following timescales:
 - e.iv.1) Response from inverter based Plant should commence within 1 second

-
- e.iv.2) All transformer and shunt tapping (where applicable) should be completed, and the operating point should be settled onto the characteristic within 2 minutes.
 - (f) Voltage Droop Control:
 - (i) Voltage Droop Control is a control function which helps to control the Voltage at the Connection Point based on a target and slope (droop) approach.
 - (ii) If the Voltage setpoint is to be changed, such change will be enacted within the timescales as detailed in Subsection 21.5 of this Grid Code.
 - (iii) The accuracy of the control performed shall be as per the tolerance values detailed in Subsection 21.5 of this Grid Code.
 - (iv) The individual Power Park Module shall be able to perform the control within its dynamic range and Voltage limit with the droop configured as shown in Figure 6. In this context, droop is percentage change in Voltage from the Voltage setpoint which will cause a change in Reactive Power exchange from zero to Q_{max} or zero to Q_{min} as appropriate.
 - (v) If the operating point of the Power Park Module deviates from the characteristic in Figure 6 the automatic control system should act to restore the operating point onto the characteristic within the following timescales:
 - f.v.1) Response from inverter based Plant should commence within 1 second
 - f.v.2) All transformer and shunt tapping (where applicable) should be completed, and the operating point should be settled onto the characteristic within 2 minutes.
 - (g) When the Voltage Control has reached the Power Park Module's dynamic design limits, the control function shall maintain this position (maximum or minimum reactive current) and await possible overall control from the tap changer or other Voltage Control functions. The Power Park Module should be designed not to trip at this time unless permitted to do so as per Subsection 12.6.7 or 12.6.9 of this Grid Code.

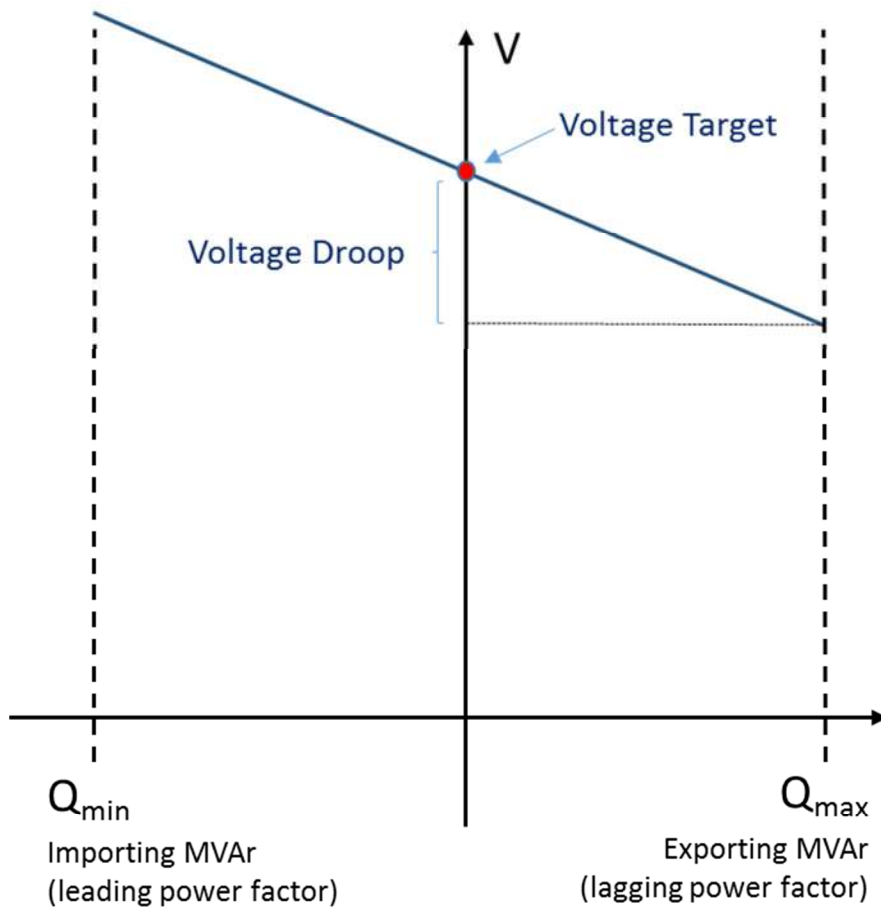

Figure 6: Voltage Droop Control for the Power Park Module

12.6.14. Active Power Curtailment for Power Park Modules:

- (a) All Power Park Modules should be capable of setting an Active Power curtailment setpoint given in MW to limit Active Power following receipt of an instruction from the System Operator.
- (b) Following an instruction to set an Active Power curtailment setpoint the Power Park Module should begin to respond to the new setpoint within 2 minutes.
- (c) The Power Park Module should ramp to the new Active Power curtailment setpoint at the ramp rate agreed with the System Operator.
- (d) Any Active Power curtailment setpoint shall apply until such times as the System Operator releases the Active Power curtailment setpoint. For the avoidance of doubt, should the Active Power of the Power Park Module decrease below the Active Power curtailment setpoint, the Active Power

curtailment setpoint will still apply as a maximum limit until released by the System Operator.

12.6.15. High Frequency Active Power reduction requirement for Power Park Modules

- (a) During excessive high frequency operating conditions, Power Park Modules shall be able to provide the mandatory Active Power reduction requirement in accordance with Figure 7 in order to assist with stabilisation of the frequency.
- (b) When the frequency on the System exceeds 50.5 Hz, the Power Park Module shall reduce the Active Power as a function of the change in frequency as illustrated in Figure 7.
- (c) If the frequency reaches 51.75 Hz the Power Park Module output should reduce to zero, at which times the requirements of 12.6.5 will apply.
- (d) The required reduction in Active Power output should commence within 2 seconds of the frequency exceeding 50.5 Hz and be continuously and linearly proportional, as far as is practicable to the characteristic in Figure 7.

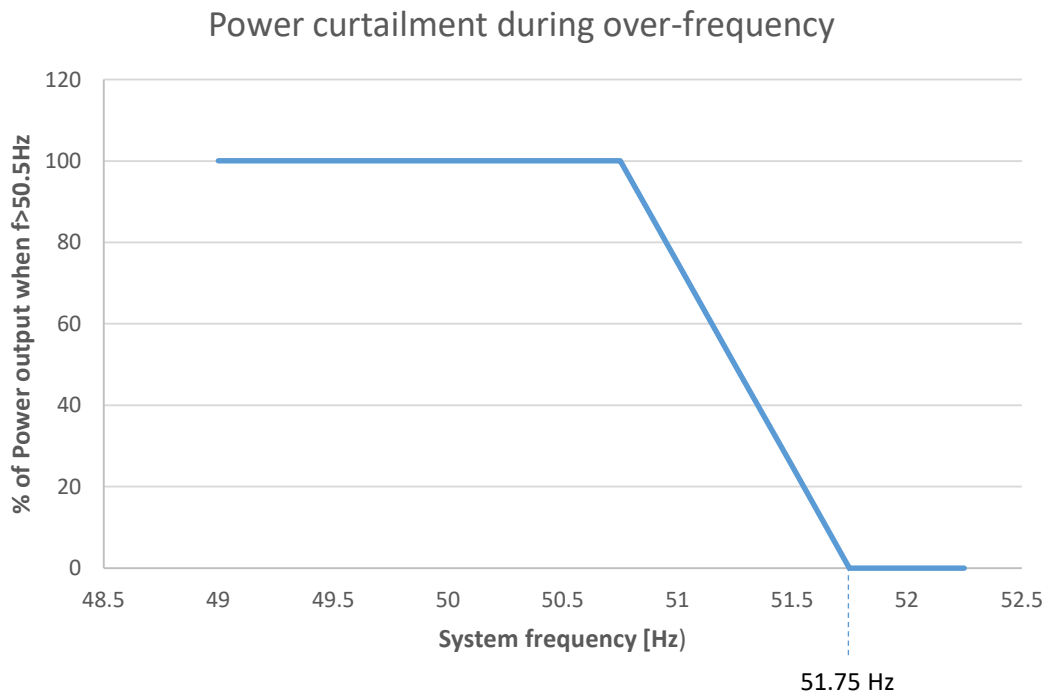

Figure 7: Power curtailment during over-Frequency for Power Park Modules

Protection Arrangements

12.6.16. Each connection between a Generating Unit or Power Park Module and the Transmission Network must be controlled by a circuit breaker capable of interrupting the

maximum short circuit current at the Connection Point as determined by the System Operator and/or the TSP.

12.6.17. The System Operator and/or the TSP shall provide each Generator at each Connection Point where its Power Station is connected with the appropriate voltage signals to enable the Generator to obtain the necessary information to Synchronise its Generating Units or Power Park Modules to the Power System.

12.6.18. Electrical protection of the Generating Unit or Power Park Module shall take precedence over operational controls (e.g. Voltage Controllers, excitation Equipment) and the Generating Unit or Power Park Module shall disconnect from the network should unacceptable Operational States arise as a result of failure of the operational controls. This shall apply in particular when spontaneous faults occur (e.g. earth faults, short-circuits).

12.6.19. The settings for the electrical protection Equipment must be agreed upon between the TSP and the Generator, and reflected in the Grid Connection Agreement. The possibility of protection and switchgear failures must also be taken into account. Consideration must be given to the following points:

- (a) For Generating Units:
 - (i) External short-circuits
 - (ii) Load unbalance
 - (iii) Stator and rotor overload
 - (iv) Under-excitation
 - (v) Over Frequency, Under-Frequency
 - (vi) Asynchronous operation
 - (vii) Torsional strain
 - (viii) Drive failure (operation as motor)
 - (ix) Measures against breaker failure
 - (x) Back-up protection
- (b) For Power Park Modules:
 - (i) Short Circuit protection
 - (ii) Over Frequency, Under-Frequency
 - (iii) Over Voltage, Under Voltage
 - (iv) Measures against breaker failure
 - (v) Back-up protection (for short circuit protection)
 - (vi) Protection against Unintentional Islanding (as detailed in 12.6.2212.6.23)

12.6.20. To cater for the possibility that the indicated fault clearance times are not met as a result of failure in the operation of the main protection systems, the Generator shall provide

the necessary back up protection. The TSP shall also provide back-up protection which shall be coordinated to provide discrimination and protect Equipment from damage.

12.6.21. Where System requirements dictate, the TSP and/or the System Operator shall specify in the Grid Connection Agreement a requirement for Generators to fit pole slipping protection on their Generating Units.

12.6.22. Unless agreed with the System Operator, Power Park Modules shall be equipped with effective protection to detect islanded operation in all System configurations and to disconnect the Power Park Module within 2 seconds. Islanded operation with part of the Transmission System is not permitted unless specifically agreed with the System Operator. Where System requirements dictate, the TSP and / or the System Operator requirement may also apply to select Generating Units.

12.6.23. Power Park Modules should ensure that protection schemes do not conflict with under and over Voltage Fault Ride Through requirements, or under and over frequency range requirements.

Work on Protection Apparatus at the Connection Point

12.6.24. No busbar protection, circuit breaker fail protection, AC or DC wiring on the Connection Facilities may be worked upon or altered:

- (a) by the TSP personnel in the absence of a representative from the Generator; and
- (b) by Generator personnel in the absence of a representative from the TSP.

Compliance Process

12.6.25. Generating Units and Power Park Modules shall follow a compliance process as detailed below. This shall apply prior to the connection and for the life of the Generating Unit or Power Park Module.

12.6.26. STAGE 1: During application for connection the Generator shall provide the System Operator with the Standard Planning Data as detailed in Section 8 of this Grid Code and Appendix 5 – Data Registration Requirements. In addition the Generating Unit or Power Park Module shall provide any additional information which may be reasonably requested by the System Operator which is necessary for assessing the application.

12.6.27. STAGE 2: After detailed Generating Unit or Power Park Module designs have been completed, at least 6 months before energisation of the Generating Unit or Power Park Module, the Generator shall provide any update of the Standard Planning Data information plus the Detailed Planning Data, including Planning Data Generation if requested, as detailed in Section 8 of this Grid Code and Appendix 5 – Data Registration Requirements. In addition, the Generator shall provide any additional information which may be reasonably requested by the System Operator at this stage. This information must be supplied and approved by the System Operator before permission to energise will be granted.

12.6.28. As part of Stage 2 compliance, Power Park Modules should submit a number of reports to the System Operator (noting that the SO will provide the necessary System data for the studies). These shall include:

-
- (a) Short circuit information for the Power Park Module detailing the short circuit currents at the Connection Point for balanced and unbalanced faults of differing severity at the Connection Point. This report should also contain information detailing how the Power Park Module should be represented in short circuit studies performed by the System Operator
 - (b) Reactive capability load flow report demonstrating compliance at 1 per unit (nominal) Voltage, and at the extremes of Voltage range, with the Power Park Module operating at full Active Power output
 - (c) Dynamic performance of the Voltage Control / Reactive Power Control system to small and large changes in Connection Point Voltage within the normal operating range
 - (d) Fault Ride Through simulation report showing balanced and unbalanced faults for depths and durations as agreed with the System Operator. The pre-fault operating condition of the Power Park Module should be the most onerous for the purpose of the study. The model used should be the same as supplied to the System Operator under Subsection 12.6.29
 - (e) Harmonic studies test report based on information and procedure as agreed with the System Operator. Power Park Unit harmonic data used for the study should be in accordance with IEC64100-21

12.6.29. A suitable and accurate dynamic model (in a format to be agreed with System Operator) of the Power Park Unit and Power Park Module is required in order to assess the impact of the Power Park Module proposed installation on the dynamic performance, security and stability of the Power System is required as part of Stage 2 compliance process. The required Power Park Module manufacturer-specific models should have the following characteristics:

- (a) Be suitable for RMS simulations typically operating with a time step of 1 – 10ms
- (b) Be suitable for symmetrical and asymmetrical network conditions
- (c) Be capable of an aggregated representation of the Power Park Module
- (d) Be validated against real Fault Ride Through type test results
- (e) And should adequately represent the following:
 - (i) Fault ride through performance including:
 - e.i.1) Fault current injection during fault period
 - e.i.2) Active power recovery post-fault
 - (ii) Voltage and Reactive Power Control performance
 - (iii) Frequency response performance (if required)

12.6.30. STAGE 3: Following energisation and commissioning of the Generating Unit or Power Park Module (or stage thereof) the Generator shall:

- (a) Provide an update of all information provided in Stage 1 or Stage 2 of the Compliance Process with the actual 'as installed' data
- (b) Perform compliance tests in accordance with Section 4 of this Grid Code which shall be agreed in detail with the System Operator. For the avoidance of doubt, these tests may include but are not limited to:
 - (i) For Generating Units:
 - i. Reactive capability test
 - ii. AVR step tests and transformer tap tests
 - iii. Power System Stabiliser tests (both time and frequency domain)
 - iv. Governor tests
 - v. Any other tests as detailed in Section 4 of this Grid Code
 - vi. Any other tests which may be reasonably requested by the System Operator to determine compliance with this Grid Code
 - (ii) For Power Park Modules:
 - i. Reactive capability test
 - ii. Voltage Control / Reactive Power Control step test and upstream transformer tap test
 - iii. Frequency response control system test
- (c) Prior to the tests conducted in (b), the Generator shall provide a schedule of tests, including a proposed methodology, to the System Operator for approval.
- (d) Following the tests conducted in (b), the Generator shall produce a report demonstrating the suitability of the submitted model (further model validation)
- (e) The Generator shall submit an approved Fault Ride Through type test report from the Power Park Unit manufacturer in lieu of a Fault Ride Through test on site as per Appendix 5 of this Grid Code
- (f) The Generator must supply certain analogue signals as per Subsection 12.4 of this Grid Code. These signals must be tested to confirm that they are functioning and suitably scaled. This can be achieved by monitoring response during the compliance tests conducted in b), or by separate Dispatch Instructions / operational monitoring. Failure of these signals must be notified to the System Operator immediately.

12.6.31. The System Operator may apply Stage 3 compliance procedures to stages / parts of a Power Park Module if it is deemed appropriate, for example due to long commissioning / construction times.

12.6.32. If at any time during the life of the Plant the Generating Unit or Power Park Module data supplied under this compliance process is no longer valid, the Generating Unit or Power Park Module shall inform the System Operator immediately. This discrepancy shall be resolved within one month, unless otherwise agreed with the System Operator.

12.6.33. Should the System Operator deem that the Generating Unit or Power Park Module is no longer compliant with any part of this Grid Code (for example through monitoring of operational performance) the System Operator may require a repeat of all or part of the Stage 3 compliance procedures (for example re-submission of data or repeat testing procedures).

CHAPTER 4: OPERATION

13. SECTION: PURPOSE AND SCOPE

13.1. OBJECTIVE

13.1.1. The general objective of this part of the Chapter is to specify the required System Operator and User actions in order to ensure that the Power System in Nigeria is operated in a way to maintain adequate and safe transportation of Energy, plus System security at all times.

13.1.2. This adequate and secure operation is achieved through:

- (a) Adequate and economic ancillary services:
 - (i) Frequency Control and Operating Reserve (Section 15)
 - (ii) Voltage Control (Section 16)
 - (iii) Black Start Capability (Section 17)
- (b) Outline the general restoration strategy adopted by the System Operator in the event of a Partial or Total Shutdown (Section 18)
- (c) Specifying Procedures for Operational Planning in the short to medium term (Section 19)
- (d) Provision of information regarding risks or events in the Transmission System (Section 20)
- (e) Determining the actions that the System Operator shall undertake to perform the economic dispatch, and to provide Generators with running orders for the Dispatch Day. (Section 21)
- (f) Defining the requirements for notification of Generation Outages to the System Operator (Section 22).
- (g) Defining the Reliability criteria that the System Operator and the TSP have to adhere to in operating and developing the Transmission System (Section 23).
- (h) Establishing central co-ordination and control of System Tests required by the System Operator, TSP or Users (Section 24)
- (i) Setting safety procedures for works to be carried out at the interface between User networks and the Transmission Network (Section 25)

13.2. SCOPE

13.2.1. The Operation Chapter applies to the System Operator, TSP and Users of the Transmission System which are:

- (a) Generators;

-
- (b) Distributors;
 - (c) Interconnected parties;
 - (d) Directly Connected Customers.

14. SECTION: POWER SYSTEM CONTROL

14.1. OBJECTIVE

14.1.1. The objective of this Section is to specify the required System Operator and User actions in order to ensure that the Power System in Nigeria is operated in such a way as to maintain adequate and safe transportation of Energy, plus System security at all times.

14.2. GENERAL

14.2.1. The System Operator shall carry out Power System Planning, Switching and Control Actions, which may from time to time affect User operations or the security of supply to Users.

- (a) Power System Planning is required for technical and design criteria and procedures to be applied by the System Operator for adequate and secure development of the Transmission Network by the TSP for the benefit of all Users.
- (b) Network switching is required to implement the Transmission Outage scheduling programme, routine operation of the Transmission Network and in response to emergency and fault situations on the Transmission Network.
- (c) Additionally, network switching may occur automatically and without advance warning due to operation of protection Equipment in isolating or clearing faults on the Transmission System or on User's Apparatus that is connected to the Transmission System.

14.2.2. All network Control Actions carried out on the Transmission System have the potential to affect Users. To attempt to inform Users of every Control Action is not practicable and in most cases the information will not be of value to the User, as the User will not take or cause any specific action as a result of receipt of the information.

- (a) It may not always be possible for the System Operator to inform Users in advance of the switching or other Control Actions. This would be the case when the System Operator needs to carry out urgent switching or other network Control Actions resulting from a Power System condition or fault. The System Operator shall endeavour to inform Users where time permits, but this shall not delay timely implementation of Control Actions as required.
- (b) In the event of a Power System fault or protection operation or other automatic operation, it will not be possible for the System Operator to invoke standing procedures prior to the occurrence of the Control Action.

14.3. POWER SYSTEM CONTROL ACTIONS

14.3.1. The System Operator shall be responsible for operating the Power System in such a way as to maintain System security, achieve highest degree of Reliability practicable and take appropriate remedial action promptly to relieve any abnormal condition that may lead to dangerous operation.

14.3.2. Consultation

The System Operator shall consult with Users and take into consideration Users' reasonable requirements in controlling the Transmission System.

14.3.3. Network switching

The System Operator shall carry out operational network switching for a number of purposes, which shall include:

- (a) Outages of Transmission Apparatus for maintenance, new works, System Tests, protection testing and work by Users;
- (b) Outages of Transmission Apparatus due to suspected or potential faults and emergency repairs;
- (c) Voltage Control; and
- (d) Limiting power flows on the Transmission System to levels consistent with the capabilities of the Transmission Plant and System security.

14.3.4. Identification of Control Actions

The System Operator shall identify the Control Actions that may be needed to carry out maintenance and operation of the Transmission System and respond to Transmission System faults and emergencies.

14.3.5. Automatic switching sequences

The System Operator shall establish automatic switching sequences to limit power flows or Voltage dip or Frequency deviations in the event of faults on the Power System.

14.4. NOTIFICATION TO ALL USERS

14.4.1. The System Operator shall notify Users of the Transmission Network of a Control Action (if planned and where time permits), in accordance with this Code.

14.5. CONTROL UNDER FAULT OR EMERGENCY CONDITIONS

14.5.1. Notification after action

In the event that the System Operator needs to implement Control Actions urgently and without informing Users, then unless the situation is of a temporary nature and has been

rectified to normal, the System Operator shall inform Users of the occurrence of the actions.

Generators shall promptly inform System Operator of the tripping of a Generating Unit, with reasons, in accordance with the guidelines in Section 21 of the Grid Code and other operational event/incident reporting Procedures operating at the time. The System Operator shall keep a written log of all such tripping, including the reasons for the purpose of demonstrating the effect on System performance and identifying the need for remedial measures. The Generators shall submit a detailed report of their Generating Unit tripping to the System Operator every month.

14.5.2. Duration of condition

The System Operator shall also inform Users as to the likely duration of the condition and shall update this prognosis as appropriate. Additionally, the System Operator shall inform Users when the condition has ended.

14.6. DE-ENERGISATION OF PLANT

14.6.1. The System Operator shall have the right to De-energise a Generating Unit or Power Park Module, as stated in the Grid Connection Agreement if it identifies any of the following causes, or any other causes detailed in the Grid Connection Agreement:

- (a) Risk to the safety of personnel;
- (b) Risk to the stability of the Power System;
- (c) Risk to the Power System or any User's Apparatus;
- (d) Power System elements that are or could become loaded beyond their emergency limits;
- (e) Voltage Fluctuations on the Power System outside the specified ranges;
- (f) Any behaviour outside normal Power System operating range;
- (g) Any material breach of a connection condition; and
- (h) Any action (or inaction) that places the System Operator in breach of any legal, statutory or regulatory obligation.

14.6.2. On a similar basis, a Generator shall have the right to De-energise a Generating Unit, as stated in the Grid Connection Agreement if it identifies any of the following causes, or any other causes detailed in the Grid Connection Agreement:

- (a) Risk to the safety of personnel;
- (b) Risk to the Generating Unit;
- (c) Frequency variations outside specified limits
- (d) Voltage Fluctuations on the Power System outside the specified ranges;

-
- (e) Any behaviour outside normal Power System operating range;
 - (f) Any material breach of a connection condition; and
 - (g) Any action (or inaction) that places the Generator in breach of any legal, statutory or regulatory obligation.

14.7. SYSTEM OPERATION PROCEDURES INCLUDING FAULT REPORTING

14.7.1. Approach

- (a) The System Operator shall develop and maintain System Operation Procedures for the safe operation of the Transmission Network, and for Apparatus connected to the Transmission Network. These System Operation Procedures shall be adhered to by Users when operating Apparatus on the Transmission Network or connected to the Transmission Network.
- (b) Each User shall be responsible for his own safety rules and Procedures at least in compliance with the relevant safety legislation. Users shall ensure that these rules and Procedures are compatible with System Operation Procedures.
- (c) Users shall enter into Operating Agreements as defined in the Grid Connection Agreement with System Operator.

14.7.2. Fault reporting and analysis/incident investigation

- (a) Generator operators shall report loss of output, tripping and pole slipping of Units and change of status of Generating Unit or Power Park Module (as appropriate) Governing / Active Power control within 15 minutes of the event occurring.
- (b) In the event of a multiple unit trip (either more than one unit tripping at the same time or one unit tripping many times), the relevant Generator shall take the following action:
 - (i) The Generator shall submit a written report to the System Operator within 48 hours of the cause of any unit trip that could in future cause that unit to trip or another unit to trip, identifying the root causes of the incident and the corrective actions taken.
 - (ii) In addition, provide a full report as per this Grid Code (in particular item (e)(ii) below).
- (c) Off-takers, shall report the loss of major Loads (>10MW) to the System Operator within 15 minutes of the event occurring. Notification of intent to reconnect such Loads shall be given at least 30 minutes in advance.
- (d) Incidents on the Power System involving sabotage or suspected sabotage, as well as threats of sabotage, shall be reported to the System Operator.

-
- (e) The System Operator shall investigate any incident that materially affected the quality of service to a User. These include interruptions of supply, disconnections, under or over Voltage or Frequency incidents, quality of supply contraventions, etc.
 - (i) a preliminary incident report shall be available after three working days and a final report within three months.
 - (ii) the System Operator shall initiate and coordinate such an investigation, arrange for the writing of the report and involve all affected Users. All these Users shall make all relevant information available and participate where reasonably required.
 - (iii) the System Operator shall make the report available to any requesting User within the confidentiality constraints, and submit it to the NERC.
 - (f) Any User shall have a right to request an independent audit of the report, at its own cost. If these audit findings disagree with the report, the User may follow the dispute resolution mechanism. If the audit agrees with the report, the report recommendations shall stand.
 - (g) User shall implement NERC-approved recommendations to reduce the likelihood of a recurrence of the incident within the time frames specified.

15. SECTION: FREQUENCY CONTROL AND OPERATING RESERVE

15.1. OBJECTIVE

15.1.1. The objectives of this Section are:

- (a) To specify the System Operator requirements to ensure that adequate Frequency Control capability is provided on the Transmission System to enable operational Frequency Control by the System Operator, so as to achieve the applicable limits, and
- (b) To specify the Operating Reserve and Reliability Must-run requirements the System Operator has to adhere to in order to achieve the mentioned Frequency Control and adequate System Reliability.

15.2. GENERAL

15.2.1. In order to maintain the security and integrity of the Transmission System it is necessary that the System Operator operate the Transmission System and Dispatch it in such a manner in order to provide adequate Frequency Control so as to achieve operation within applicable Frequency limits at all times. Frequency Control can be obtained by using primary or secondary Reserve.

15.2.2. Depending on network condition, Generating Units will be required to move to or from Frequency Sensitive mode in combinations agreed in the relevant Ancillary Services Agreement or as instructed by the System Operator.

15.2.3. In order to achieve this Control, the System Operator shall operate the System with adequate Operating Reserve. Operating Reserve is additional Active Power output provided from Generating Units, or a reduction in consumer Demand, which must be realisable in real-time operation to contain and correct any potential Power System Frequency deviation to an acceptable level.

- (a) Operating Reserve is required to secure capacity that will be available for reliable and secure balancing of supply and demand.

15.3. FREQUENCY LIMITS

15.3.1. The Frequency shall be maintained at 50 Hz. The National Control Centre will endeavour to control the System Frequency within a narrow operating band of +/- 0.5% (49.75 – 50.25 Hz) from 50 Hz, at least 97 % of the time during Normal Conditions. Under System Stress the Frequency Control on the Power System will be exercised within the limits of 50 Hz +/- 2.5% (48.75 – 51.25 Hz).

15.4. FREQUENCY CONTROL

15.4.1. During Normal Conditions, Frequency Control will be exercised utilizing the Quick Reserve (Primary, Secondary and Tertiary Reserve). Occasionally, also the Emergency Reserve will be used.

15.4.2. The Nigerian Power System requires a minimum Primary Reserve that is sufficient to cover the Largest Credible Trip in order to secure the network. The “Largest Credible Trip” is the largest loss of power inflow that could be caused by a single trip, which will normally be the largest Generating Unit Synchronised to the System; however it could be an inflow from an exporting area that flows through a double circuit. (As at 2012 the largest Generating Unit on the System is 220MW.) The level of Secondary Reserve should at least be equal to the allocated Primary Reserve. The level of Tertiary Reserve should at least be equal to the allocated Secondary Reserve plus that required for managing Load and Power Park Module forecast errors.

- (a) The System Operator shall distribute the required Primary, Secondary and Tertiary Reserve power among the contributing Generating Units.
- (b) The Generators shall be responsible for continuous secure maintenance of their Frequency Control Equipment and communication Equipment required for providing Secondary Reserve and Tertiary Reserve, as instructed by the System Operator.

15.4.3. Shortfall: The System Operator shall evaluate the Frequency Control performance during the day of operation and identify any shortfall. The System Operator shall instruct a Generator(s) to perform Frequency Control to counteract the shortfall.

15.5. COMPONENTS OF OPERATING RESERVE

15.5.1. Operating Reserve is inclusive of all reserves in the Power System. These are shown in Figure 8 below.

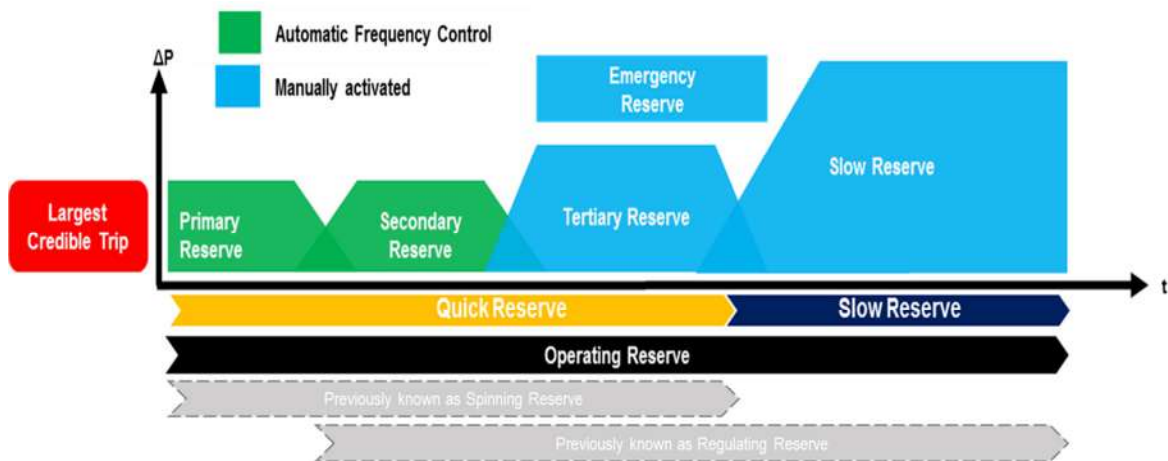

Figure 8: Different types of Operating Reserves in Nigeria with indicative timescales of response and volumes required

15.5.2. There are two types of Operating Reserve, namely Quick Reserve and Slow Reserve. Quick reserve is used to maintain the balance of supply and demand when an unexpected System event occurs. These reserves provide capacity the System controller can call on at short notice to correct any imbalance. These reserves can come from the supply side (Generating Units) or from the demand side (Load management). Quick reserves are the fastest acting contingency reserve. Generating Units or Loads providing quick reserves are synchronized to the grid and are partially loaded. This feature allows the reserve to be provided very quickly. In addition to the ability to respond very quickly, quick reserves also provide frequency support to the Power System. Slow reserves on the other hand are not necessarily required to be synchronized to the grid and are slower to respond when called.

15.5.3. **Quick Reserve** is used for balancing the System within one Dispatch Period. During Normal Operation, Primary, Secondary and Tertiary Reserve are used for this service. During Emergency situations, Emergency Reserve can be used additionally.

- (a) Primary Reserve and Secondary Reserve are activated automatically for controlling the Frequency of the System.
 - (i) Note that Primary and Secondary Reserve have previously been referred to as regulating reserve.
- (b) Tertiary Reserve and Emergency Reserve are manually activated by the System Operator and are used for substituting Primary and Secondary Reserve and for balancing the System in the time frame of several minutes
- (c) **Normal Operation**
 - (i) **Primary Reserve:** Primary Reserve is an automatic increase or decrease in Active Power output of a Generating Unit in response to a System

Frequency fall or rise, in accordance with the primary control capability and additional mechanisms for controlling Active Power. This change in Active Power output must be in accordance with the technical characteristics and loading of the Generating Unit, without any time delays other than those necessarily inherent in the design of the Governor Control System. Primary Reserve (positive and negative) must respond immediately and must be fully active within 10 seconds and sustained for at least one hour. All online generation resources must have their turbine governors in service and unblocked as specified in the Subsection 12.6.2 of this Grid Code.

- (ii) **Secondary Reserve:** Secondary Reserve is the automatic response to Frequency changes which is fully available within 30 seconds from the time of Frequency change to take over from the Primary Reserve, and which is sustainable for a period of at least one hour.
 - (iii) **Tertiary Reserve:** Tertiary Reserve is required to balance supply and demand for changes within a one-hour dispatch interval. Tertiary Reserve is used to restore Secondary Reserve when required. Tertiary Reserve must be fully activated within 10 minutes from the instruction of the SO and shall be sustained for at least two hours.
- (d) **Emergency Conditions**
- (i) **Emergency Reserve:** Emergency Reserve is typically made up from contracted interruptible Load, gas turbines and Emergency Generation. Emergency Reserve is a less frequently used reserve and is used when the Transmission Network is not in a normal condition and to return the Transmission Network to normal conditions while slower reserves are being activated. Emergency Reserve can be used by the System Operator for supply and demand balancing, network stability and Voltage constraints. Emergency Reserve shall be fully active within ten minutes from an instruction of the SO and shall be sustained for at least two hours.

15.5.4. **Slow Reserve:** Slow Reserve is the component of the Operating Reserve not synchronized to the Transmission System but capable of serving demand within a specified time. Slow Reserve is used to restore Quick Reserve when required. Slow Reserve is required for compensating imbalance resulting from day-ahead prediction errors or unexpected Generating Unit trips. Slow Reserve must be fully activated within a specified time (e.g. one hour) and must be sustained for at least 4 hours. Actual times for activation and sustained availability are subject to bilateral agreements.

15.5.5. **Negative Reserve:** Negative Reserve is the ability of power Plants to reduce their Active Power output for balancing the System in the case of excess of Generation (situations of high Frequency).

- (a) **Negative Primary Reserve:** Generating Units providing Primary Reserve must always be capable of providing the same amount of Negative Reserve without breaching the operating limits of the Generating Unit.

-
- (b) **Negative Secondary & Tertiary Reserve:** Generating Units providing Secondary & Tertiary Reserve must be capable of providing Negative Secondary & Tertiary Reserve.
 - (c) **Negative Emergency Reserve:** All Generating Units in operation must provide negative Emergency Reserve, meaning that they follow the instructions of the System Operator for reducing their Load if required.

15.5.6. **Reserve Requirements:** All Generators, and Off-Takers providing any of the above defined reserves must comply with the following reserve requirements:

- (a) Primary Reserve:
 - (i) Activation Time (fully active): 10s
 - (ii) Sustained for: 1h
 - (iii) Continuously adjustable
 - (iv) Controller/communication: local Frequency Controller
- (b) Secondary Reserve:
 - (i) Activation Time (fully active): 30s
 - (ii) Sustained for: 1h
 - (iii) Continuously adjustable
 - (iv) Controller/communication: communication interface for integration into AGC/secondary controller of the System Operator
- (c) Tertiary Reserve:
 - (i) Activation Time (fully active): 10 minutes
 - (ii) Sustained for: 4h
 - (iii) Continuously adjustable
 - (iv) Controller/communication: communication interface for instructions of the System Operator or dedicated telephone line for instructions of the System Operator ensuring that the required Activation Time of 10 minutes can be met.
- (d) Emergency Reserve:
 - (i) Activation Time (fully active): 10 minutes
 - (ii) Sustained for: 4h
 - (iii) Continuously adjustable or discrete steps.
 - (iv) Controller/communication: communication interface for instructions of the System Operator or dedicated telephone line for instructions of the System Operator ensuring that the required Activation Time of 10 minutes can be met.

-
- (e) Slow Reserve:
 - (i) Activation Time (fully active): mutually agreed (>1h)
 - (ii) Sustained for: mutually agreed (at least 4h)
 - (iii) Continuously adjustable or discrete steps
 - (iv) Controller/communication: communication interface for instructions of the System Operator or dedicated telephone line for instructions of the System Operator ensuring that the required Activation Time can be met.

15.6. OPERATING RESERVE POLICY

15.6.1. The System Operator shall, in consultation with the Users, specify the Operating Reserve Policy, including its allocation of the permissible mix of Quick Reserve and Slow Reserve, and the Procedure for applying Operating Reserve in practice, and the limitations, if any, upon the amount of Interruptible Load which may be included. The System Operator shall submit the Operating Reserve Policy to the NERC for approval.

15.6.2. In developing the Operating Reserve Policy, due consideration shall be taken of relevant factors, including, but not limited to the following:

- (a) The cost of providing Operating Reserve at any point in time;
- (b) The magnitude and number of the largest Generation in-feeds to the Transmission System at that time, including in-feeds over Interconnections and also over single Transmission feeders (which may be single or double circuit) within the Transmission System;
- (c) Ambient weather conditions, insofar as they may affect (directly or indirectly) Generating Unit and/or Transmission System Reliability;
- (d) The predicted Frequency drop on loss of the Largest Credible Trip as determined through simulation using a dynamic model of the Power System;
- (e) Constraints imposed by agreements in place with externally interconnected parties;
- (f) Historical Availability and Reliability performance of individual Generating Units;
- (g) Notified risk to the Reliability of individual Generating Units; and
- (h) Imbalance power requirements resulting from uncertainties of Demand and Power Park Module forecasts.
- (i) Load following requirements resulting from the continuous variation of Demand and Power Park Module output during a Dispatch Period.

15.6.3. Unless proved to be technically impossible, or the economic burden imposed on the dispatch cost is excessive, the precise methodology for allocating reserve must be defined by TCN and agreed with NERC, and must be in-line with the following principles:

-
- (a) **Primary Reserve:** the SO shall ensure that enough Primary Reserve is available to maintain System Frequency within acceptable limits, following a contingency such as a unit trip or a sudden surge in Load, without any Under-Frequency Load Shedding. The requirement on the SO is to keep the frequency above 48.75 Hz following all credible single contingency losses. The SO shall ensure that the same volume of Negative Primary Reserve is available. Those Generating Units that are contracted for Primary Reserve are also required to provide the same capacity for Negative Primary Reserve for high frequencies.
 - (b) **Secondary Reserve:** sufficient Secondary Reserve shall be carried to ensure that any decay in Primary Reserve is replaced. The same volume of Negative Secondary Reserve shall be carried, however this may come from other sources.
 - (c) **Tertiary Reserve:** the SO must ensure that sufficient Tertiary Reserve is available to restore Primary and Secondary Reserve following a contingency or to compensate the maximum residual load variability value within any one-hour interval (maximum difference between instantaneous value of Load or residual Load and one hour average value) minus the allocated Secondary Reserve. The same volume of Negative Tertiary Reserve shall be carried, however this may come from other sources.
 - (d) **Emergency Reserve:** the SO must ensure that sufficient Emergency Reserve is available for compensating the worst-case credible multiple contingency loss (e.g. simultaneous outage of two large gas turbine Generating Units).
 - (e) **Slow Reserve:** The SO must ensure that sufficient Slow Reserve is available to restore Tertiary Reserve plus Emergency Reserve following a contingency and to compensate for the worst-case imbalance error resulting from day-ahead forecast errors of the available generation and Load. Slow reserve should be procured on an hour-by-hour basis. It should predominantly be procured from hydro power Plants, operating under water management and gas turbine Generating Units that operate under fuel management.
 - (f) Operating Reserve shall be considered the effective use of capacity in an emergency and shall be dispersed throughout the System taking into account the time required to be effective, transmission limitations, and local area requirements.

15.6.4. The System Operator shall, in consultation with the other Users, review probable contingencies frequently to determine the adequacy of Operating Reserve Policy, maintain it permanently under review. On an annual basis, it shall submit to the NERC an amended version for approval, taking into consideration the previous year's Frequency recovery performance.

15.6.5. **Record keeping:** The System Operator shall keep records of significant alterations to the Operating Reserve Policy.

15.7. AMOUNT OF OPERATING RESERVE

15.7.1. The System Operator shall be responsible for determining the amount of Operating Reserve required for each Dispatch Period of the Dispatch Day, to be carried at any time to ensure System security, according to the Operating Reserve Policy approved by the NERC.

15.7.2. In order to adequately and efficiently determine the amount of Operating Reserve:

- (a) Each Generator shall keep the System Operator informed of the Availability of its Generating Units.
- (b) The System Operator shall keep proper records of the Availability of its transmission resources.
- (c) The System Operator shall have information, including weather forecasts and past Load patterns available to predict the Power System's future Load.

15.7.3. The System Operator shall operate the Power System to provide for a level of Operating Reserve sufficient to account for such factors as errors in forecasting, generation and Transmission Equipment unavailability, number and size of Generating Units, System Equipment Forced Outage rates, maintenance schedules and regulating requirements. The System Operator shall take appropriate steps to protect the Power System against the next contingency, following the loss of Generation resources or Load.

15.8. OPERATING RESERVE PROCUREMENT

15.8.1. Not all components of Operating Reserve are Ancillary Services. The System Operator is mandated to procure this Ancillary Service and shall contract for those components of Operating Reserve that constitute Ancillary Service as listed in Subsection 15.6 to enable it to operate the Transmission System securely at all times.

15.8.2. Primary Reserve is not an Ancillary Service and is defined in the following paragraph, Subsection 15.8.3.

15.8.3. **Governor Control System:** in order that adequate Frequency Control is maintained on the Power System at all times, Generators are required to provide the Primary Reserve specified by the System Operator, complying with the following requirements:

- (a) Generating Units, when Synchronised to the Power System, shall operate at all times under the control of a Governor Control System, unless otherwise specified by the System Operator, with characteristics within the appropriate ranges as specified in connection conditions.
- (b) No time delays other than those necessarily inherent in the design of the Governor Control System shall be introduced.
- (c) No Frequency dead bands shall be applied to the operation of Governor Control Systems.
- (d) Power Park Modules are not required to provide Primary Reserve, however if agreed between the Generator and the System Operator, they may participate

and will be bound by the requirements in this Subsection 15.8 of the Grid Code as per Generating Units.

15.8.4. **Restriction of governor action:** The Generator shall only restrict governor action where:

- (a) the action is essential for the safety of personnel and/or to avoid damage to Plant; or
- (b) in order to secure the Reliability of the Generating Unit; or
- (c) the restriction has been agreed upon between the System Operator and the Generator in advance; or
- (d) the restriction is in accordance with a Dispatch Instruction given by the System Operator. The System Operator shall record the nature of the restriction, the reasons, and the time of occurrence and duration of the restriction.

15.8.5. For all other types of Operational Reserve:

- (a) Reserve Responsibilities: The System Operator shall agree on an annual basis with the Generators all the conditions relating to Frequency Control. This shall include the possible range that each participating Generating Unit can comply to and the time of the year when it shall be possible technically. The System Operator shall decide on the scheduling of the different Generating Units to perform Frequency Control. The System Operator shall base this on an economic evaluation and Availability of the Generating Units. The System Operator shall instruct the Generating Units one day before they will be required to perform Frequency Control.
 - (i) The System Operator shall ensure that there is a balance between Generation and Load. The System Operator shall achieve this by ensuring adequate reserve at all times.

15.8.6. **Reliability Must-Run Requirements:** The System Operator shall contract Reliability Must-run Generating Units to cater for situations where Emergency Reserve power is needed to keep the Power System secure.

- (a) The System Operator shall determine the needed Reliability Must-run requirements by performing extensive Reliability studies on the Power System, taking the scheduled Outages into account.
- (b) The System Operator shall quantify the risk the Transmission System is exposed to due to unanticipated Outages. Based on this risk assessment, additional Reliability Must-run Agreements might be needed.
- (c) The System Operator shall report on all Reliability Must-run Agreements by including the details in the Reliability annual assessment report on an annual basis to the NERC. This report shall address the reasoning for each Reliability Must-run Agreement and the achieved performance of each Reliability Must-run Unit.

16. SECTION: VOLTAGE CONTROL

16.1. OBJECTIVE

16.1.1. The objective for Voltage Control is to achieve a healthy Voltage profile for the Power System.

16.2. GENERAL

16.2.1. The System Operator shall endeavour to maintain sufficient Availability of dynamic and static Reactive Power in order to maintain the Power System Voltages at Connection Points within the levels specified, at all times.

16.2.2. The System Operator should use the effects of Power System capacitance in controlling the Power System Voltage.

16.2.3. The System Operator can operate the Power System Voltage towards the upper portion of the allowable control range at times of high Reactive Power Demand (normally times of high Active Power Demand).

16.2.4. The System Operator can operate the Transmission System Voltage towards the lower portion of the allowable control range at times of low Reactive Power Demand (normally times of low Active Power Demand).

16.3. VOLTAGE CONTROL

16.3.1. Responsibility: The System Operator shall be responsible for:

- (a) maintaining Voltage stability of the Power System; and
- (b) maintaining Power System Voltages at User Connection Points within operational limits.

16.3.2. **Dispatch:** The System Operator shall, by means of Dispatch Instructions, instruct Generators to adjust the Voltage level at the Connection Point or the Reactive Power output of Generating Units or Power Park Modules.

16.3.3. **Control facilities:** The System Operator shall adjust Power System Voltages, using available control facilities. This is to achieve the Reactive Power capacity necessary in order to maintain Power System Voltages at Connection Points within the specified levels.

16.4. VOLTAGE CONTROL POLICY

16.4.1. **Transmission System losses:** The System Operator shall control System Voltages in order to maximize the Reliability of the Power System, trying, when possible, to minimise Transmission System losses and the cost of the Ancillary Services.

16.4.2. **Procedures:** The System Operator shall determine and modify, as appropriate, general Procedures for controlling Voltages on the Power System. The Procedures shall be

formulated considering the relevant economics of Power System operation and Power System Reliability. In determining these Procedures, the System Operator shall consider daily, weekly and seasonal factors. The System Operator shall determine:

- (a) suitable target Voltages in order to limit/control the effect of Transmission Capacitance;
- (b) best utilisation of dedicated Voltage Control facilities; and
- (c) Reactive Power dynamic reserve requirements.

16.5. VOLTAGE CONTROL METHODS

16.5.1. The System Operator shall use the following Voltage Control methods:

- (a) Transformer tap-changing, cable switching, reactor and capacitor switching, and other control methods which involve utilisation of Transmission System Plant only;
- (b) Tap-changing on Generating Unit transformers;
- (c) Demand power factor correction;
- (d) Utilisation of Generating Unit or Power Park Module Reactive Power capability, both by means of AVR control and also Reactive Power Dispatch Instructions or Power Factor Dispatch Instructions issued by the System Operator to Generators; or
- (e) Eventually, and only if Reliability of the Transmission System is not heavily affected, the switching of Transmission Lines in order to reduce the capacitive contribution of the Transmission System.

16.5.2. **Monitoring:** The System Operator shall monitor the Transmission System Voltages continuously. Appropriate Voltage operating points shall be determined by the System Operator, taking account of the Voltage Control policy and in particular of System conditions prevailing at the time of operation.

16.6. VOLTAGE CONTROL DURING EMERGENCIES

16.6.1. The System Operator shall utilise additional Voltage Control mechanisms in the event of System Emergency Conditions. These shall include the following:

- (a) Generators may be requested to operate Generating Units at Reactive Power levels (delivering or absorbing) outside their currently registered operating characteristics. This will be done by agreement between the Generators and the System Operator and Generators will not be penalised for non-compliance with this Subsection;
- (b) System wide restoration of Voltages by instructing Generators to carry out a tap-change on the main Generating Unit transformer of several Generating Units simultaneously; and

-
- (c) Load shedding may be used to prevent Voltages from contravening Low Voltage limits at Connection Points.

16.7. PROVISION OF VOLTAGE CONTROL

16.7.1. The System Operator may establish contract for Voltage Control with some Users in order to enable the Power System to be operated efficiently and securely at all times.

- (a) Each Generator shall inform the System Operator of the Capability Chart of each Generating Unit or Power Park Module. In case there exists a seasonal or permanent technical restriction that could prevent the Generating Unit or Power Park Module from producing Reactive Power within the limits of this curve, this situation shall be reported to the System Operator.
- (b) The Generating Unit shall normally be operated under the control of a continuously acting AVR, which shall be set so as to maintain a constant terminal Voltage within the Voltage range specified by the System Operator. While the Reactive Power produced by the Generating Unit is within the limits indicated in the Capability Chart, the Generator may only disable or restrict AVR action:
 - (i) where the action is essential for the safety of personnel and/or Plant;
 - (ii) in order to secure the Reliability of the Generating Unit; or
 - (iii) where the restriction has been agreed upon between System Operator and the Generator in advance.
- (c) When a Generator identifies that, due to technical or operational problems or constraints, its capability to provide Reactive Power has reduced compared to the normal capability informed to the System Operator, then it shall inform as soon as practicable the System Operator of this constraint.
- (d) **Generating Unit restrictions:** The System Operator may impose restrictions on the operation of the Generating Unit in accordance with Good Utility Practice in the event of a Generating Unit not operating under AVR. This shall provide for safe and secure operation of the Power System and operation within prescribed standards, including where necessary instructing the Generator to De-energise the Generating Unit.
- (e) **Minimum Requirements for Off-takers:** the Off-takers shall maintain a lagging Power Factor not less than 0.90 at the Connection Point.

16.7.2. During the Medium Term Stage:

- (a) Minimum Requirements for Generating Units
 - (i) The minimum amount of Reactive Power each Generating Unit shall be able to produce, if required by the System Operator, is defined by the following limits:

-
- a.i.1) Inductive: 25 % of the rated Active Power ($\cos \phi = 0.97$ at full output)
 - a.i.2) Capacitive: 15 % of the rated Active Power ($\cos \phi = 0.989$ at full output)

The Generating Unit shall be able to deliver this Reactive Power within the whole range of generated Active Power (from technical minimum to rated capacity)

- (ii) Each Generating Unit shall normally be operated under the control of a continuously acting AVR, which shall be set so as to maintain a constant terminal Voltage within the Voltage range specified by the System Operator. The Generator shall not disable or restrict the operation of the AVR except for the conditions identified below, in which event the Generator shall notify the System Operator without delay.
 - (iii) **AVR restriction:** While the Reactive Power produced by the Generating Unit is within the limits indicated in Section 12 of the Connection Conditions the Generator may only disable or restrict AVR action-
 - a.iii.1) where the action is essential for the safety of personnel and/or Plant;
 - a.iii.2) in order to secure the Reliability of the Generating Unit; or
 - a.iii.3) where the restriction has been agreed upon between System Operator and the Generator in advance.
 - (iv) **Generating Unit restrictions:** The System Operator may impose restrictions on the operation of the Generating Unit in accordance with Good Utility Practice in the event of a Generating Unit not operating under AVR. This shall provide for safe and secure operation of the Power System and operation within prescribed standards, including where necessary instructing the Generator to De-energise the Generating Unit. The System Operator shall consult with the Generator as soon as possible after such actions had been taken in order to determine a safe operating regime, which causes minimum restriction on the operation of the Generating Unit.
- (b) **Minimum Requirements for Off-takers**
 - (i) The Off-takers shall maintain a Power Factor not less than 0.95 at the Connection Point.
 - (c) **Additional requirements for Voltage Control**
 - (i) In case the System Operator considers that additional means of Voltage Control are required in the Transmission System (in excess of those previously stated), it can procure them, establishing contracts with Users.

17. SECTION: BLACK START

17.1. OBJECTIVE

17.1.1. The objective of this Section is to stipulate the Black Start requirements the System Operator has to cater for.

17.2. GENERAL

17.2.1. Generating Units have to be identified that can start on own resources from a total De-energised state which may be due to emergency condition declared by System Operator as in Section 18 or Appendix 8 of this Code. Such Generating Units may be necessary to start other Generating Units and revive the Power System following a Total Shutdown. The necessary contracts must be executed between the System Operator and Generators to provide Black Start Capability and appropriate tests must be done on a regular basis to ensure that the Power System can be reactivated following such an extreme emergency situation.

17.3. ANCILLARY SERVICE

17.3.1. Black Start is a mandatory Ancillary Service. The System Operator shall contract for Black Start to enable it to operate the Power System securely at all times.

- (a) Existing Generators can appeal to the SO for derogation from this duty; or
- (b) New Generators can appeal to SO/TSP for derogation on the basis of: technological incapability (e.g. wind and photo-voltaic), size (e.g. small hydro) or excessive cost (note in this case the SO may choose to cover the extra cost in the Ancillary Service Agreement).

17.4. REQUIREMENTS

17.4.1. The System Operator shall set out the requirements for Black Start Stations to enable recovery of the Power System from a Partial Shutdown or Total Shutdown.

17.4.2. Requirements for Black Start Stations:

- (a) Black Start Stations shall have the ability for at least one of its Generating Units to start-up from shutdown and to energise a part of the total System, or be Synchronised to the System.
- (b) The Black Start Stations shall perform Black Start upon instruction from the System Operator, without an external electrical power supply.
- (c) The Black Start Power Station shall inform the System Operator if during the Demand restoration process any Black Start unit cannot, because of the Demand being experienced, keep within its safe operating parameters.
- (d) The System Operator shall where possible, either instruct Demand to be altered or will re-configure the Transmission System or will instruct a User to re-

configure its System in order to alleviate the problem being experienced by the Generator.

- (e) However, the System Operator may decide to keep a Generating Unit in a Power Station operating outside its safe operating parameters, for a limited period of time. The System Operator shall accept that the Generator operator may change Generation on that unit if it believes it is necessary for safety reasons. The Generator shall inform the System Operator as soon as reasonably practicable if such a change is made without prior notice.

18. SECTION: EMERGENCY OPERATION AND RESTORATION

18.1. OBJECTIVE

18.1.1. The objective of this Section is to outline the general restoration strategy, which shall be adopted by the System Operator in the event of a Partial or Total Shutdown of the Transmission System, emergency condition or that indicated in Appendix 8. This includes the need for a restoration plan and an Under-Frequency Load Shedding scheme.

18.2. GENERAL

18.2.1. The Operating States of a Power System are classified into five Operating States, namely normal, alert, emergency, extreme and restorative.

18.2.2. The different Operating States can be defined as follows:

(a) Normal Operating State

The Power System variables, Voltage and lines, are within the normal range and no Equipment is being overloaded. The Power System operates in a secure manner and can withstand any single contingency without violating any of the limits.

The Power System should be in this mode of operation for most of the time. The System Operator shall endeavour to operate the Power System such that it is in the normal Operating State.

(b) Alert Operating State

The Power System will move into this state of operation once the security level falls below a certain limit. This could also be due to the possibility of a disturbance due to bad weather conditions, such as a severe storm.

The Power System variables, Voltage and lines, are within acceptable operating range and limits. However, the Power System is weakened and the next contingency could cause an overload or Voltage violation.

(c) Emergency Operating State

The Power System will move into this state of operation if a severe disturbance occurs or under a civil emergency situation as in Appendix 8, when the System is in the alert operating state. Some of the busbar Voltages will be low and/or Equipment will exceed its short-term emergency ratings. The System will still be intact and can return to the alert Operating State once the emergency actions have been initiated, such as fault clearing, excitation control, generating tripping and Load curtailment.

(d) Extreme Operating State

The Power System will move into this state of operation once the emergency actions have failed to be effective. This will result in a possible cascade tripping of the transmission lines and Generating Units and a possible Shutdown of a part of the Power System. The Power System can then be saved by the initiation of Under-

Frequency Load Shedding and controlled separation of portions of the Power System.

(e) Restorative Operating State

The System Operator shall reconnect all the facilities and restore the System Load during this Operating State either through the approach in this Section 18 or any other safe method deemed necessary by System Operator. The Operating State of the Power System will then move from Extreme Operating State to Restorative Operating State until it has once again reached the Normal Operating State.

18.3. EMERGENCY OPERATION

18.3.1. Operating State Responsibility

System Operator shall always be in a position to determine the Operating State of the Power System. The System Operator shall be responsible for informing all Users involved once the Operating State changes from one Operating State to another.

18.3.2. System Operator shall develop and maintain contingency plans to manage System contingencies and emergencies that are relevant to the performance of the Transmission Network. Such contingency plans shall be developed in consultation with all Users, which shall be consistent with the actual situation of the Nigerian Power System and international utility best practices. It shall include but not be limited to:

- (a) Under-Frequency Load Shedding
- (b) meeting System disaster management requirements including the necessary minimum Load requirements
- (c) Forced Outages at all points of interface, and
- (d) supply restoration.

18.3.3. Emergency plans shall allow for quick and orderly recovery from a partial or complete System collapse, with least cost solution and minimum impact on Users and customers.

18.3.4. The System Operator shall periodically verify contingency and/or emergency plans by actual tests to the greatest practical extent possible. In the event of such tests causing undue risk or undue cost to a User, the System Operator shall take such risks or costs into consideration when deciding whether to conduct the tests. Any tests shall be carried out at a time that is least disruptive to the User and customers. The costs of these tests shall be borne by the respective asset owners. The System Operator shall ensure the co-ordination of the tests in consultation with all affected Users.

18.3.5. The System Operator shall specify minimum emergency requirements for Distribution Control Centres, Power Station Control Centres and substations to ensure continuous operation of their control, recording and communication facilities.

Other Users shall comply with the System Operator's reasonable requirements for contingency and emergency plans.

18.3.6. The System Operator shall set the requirements for automatic and manual Load shedding. Users shall make available Loads and schemes to comply with these requirements.

18.3.7. The System Operator, in consultation with the TSP shall be responsible for determining all operational limits on the Transmission Network, updating these periodically and making these available to the Users.

18.3.8. The System Operator shall conduct load flow studies regularly (at least monthly) to determine the effect that various component failures would have on the Reliability of the Transmission Network. At the request of the System Operator, Distribution Network Operators shall perform related load flow studies on their part of the network and make the results available to the System Operator.

18.3.9. Procedures and facilities

System Operator shall ensure that the necessary Procedures and facilities are in place to support quick and secure re-establishment of the Shutdown parts and restore supply to Users.

18.3.10. Safety

The System Operator shall De-energise certain Plant in order to provide for safe and secure operation of the Transmission System within prescribed standards, including:

- (a) During a System Emergency Condition;
- (b) During Power System restoration; and
- (c) Following the issue of a declaration of being in an Extreme Operating State.

18.4. RESTORATION OF SUPPLY

18.4.1. Restoration plan

The System Operator shall develop and maintain a well-documented Power System restoration plan for the Nigerian Power System. The System Operator shall consult with all the stakeholders on at least an annual basis to review the restoration of supply in Nigeria. The Power System restoration plan shall include the restoration of the Power System from a Total Shutdown and shall also address a Partial Shutdown.

The System Operator shall inform all the Users of the Procedure for Power System restoration at the time of a Partial or Total Shutdown. Each User shall abide by the System Operator's instructions during the restoration process, subject to the safety of personnel and the Users' Plant.

18.4.2. Training

The System Operator shall be responsible for the training of all personnel who may be involved in Power System restoration. They must be familiar with, and adequately trained and experienced in their standing instructions and other obligations so as to be able to implement the Procedures and comply with any Procedures notified by the System Operator.

18.4.3. Extreme Operating State test

The System Operator shall, in consultation with all stakeholders, issue an Extreme Operating State declaration at least once each year. This will be a test and not a real situation. The purpose of this would be to ensure proper training of all personnel involved. The stakeholders shall be notified in advance of the content of the tests and a date and time for execution of the tests shall be agreed. The stakeholders must, acting in accordance with Good Utility Practice, co-operate with any such testing.

18.5. BACK-UP CONTROL CENTRE

18.5.1. Plan

The System Operator shall have a plan to continue its operations in the case of the National Control Centre becoming inoperable. This plan could include a permanent Back-up Control Centre shadowing the main National Control Centre with the appropriate trained staff on site. In this case the Back-up Control Centre shall be located remote from the site of the National Control Centre.

18.5.2. Training

The System Operator shall also ensure that the staff members of the Back-up Control Centre have been well informed and well trained to enable them to operate the Power System securely. This site shall also be equipped with the required telecommunication infrastructure capable of transferring all relevant data and the required voice communications needed to operate the Power System.

18.6. EMERGENCY CO-ORDINATION FACILITY

18.6.1. The System Operator shall make provision for an emergency co-ordination facility as part of the restoration plan.

18.6.2. The emergency co-ordination facility shall mean a site, remote from the National Control Centre, providing at least the minimum level of communication capabilities necessary for operation of the Power System. The emergency co-ordination facility shall be utilised in the event that an emergency situation or major failure of facilities at the NCC (and/or Back-up Control Centre if applicable) prevents operation from either the NCC or the Back-up Control Centre.

18.6.3. In the event of the emergency co-ordination facility being utilised, the System Operator shall be able to communicate with the following stakeholders during such an emergency:

- (a) All Users;
- (b) The Commission;
- (c) The Federal Government; and
- (d) The Defence force.

18.6.4. The System Operator shall ensure that the emergency co-ordination facility is equipped with up to date Single Line Diagrams, operating diagrams and System Operation Procedures at least once a year.

18.7. UNDER-FREQUENCY LOAD SHEDDING

18.7.1. Policy and analysis

The Under-Frequency Load Shedding shall be the last step during an emergency. All other remedial steps should have been taken already.

The Under-Frequency Load Shedding scheme shall be studied by the Operational Planning staff on an annual basis and it shall be the responsibility of the TSP to promptly implement any modifications.

Under-Frequency Load Shedding shall be in steps related to one or more of the following: Frequency, rate of Frequency decay, Voltage level, and rate of Voltage decay or power flow.

The System Operator shall be responsible for compiling a proper Under-Frequency Load Shedding scheme policy. This policy shall be revised as necessary and the scheme shall be revised on an annual basis or when the policy changes. As initial policy, five Under-Frequency Load Shedding steps can be recommended. However, this needs to be studied in detail by the Operational Planning staff. These five steps are:

- (a) 10 % of the maximum Demand at 49.2 Hz with a 0.3 second delay;
- (b) 10 % of the maximum Demand at 49.0 Hz with a 0.3 second delay;
- (c) 10 % of the maximum Demand at 48.8 Hz with a 2 second delay;
- (d) 10 % of the maximum Demand at 48.5 Hz with a 2 second delay; and
- (e) 10 % of the maximum Demand at 48.2 Hz with a 2 second delay.

[Note: The above-mentioned steps are an example only. The specific conditions in Nigeria need to be studied in order to develop suitable steps for the Nigerian Power System].

18.7.2. Under-Frequency Load Shedding scheme

The System Operator shall ensure that the Power System is equipped with a well-coordinated Under-Frequency Load Shedding scheme.

The Under-Frequency Load Shedding scheme shall automatically be activated by the relays for insufficient Generation or Transmission capacity to safeguard the Power System.

The System Operator shall ensure that the Under-Frequency Load Shedding relays are located on circuits where it is less likely that the Loads can be switched away.

18.7.3. Co-ordination

Under-Frequency Load Shedding shall be coordinated throughout the Power System with other Under-Frequency isolation, such as Generating Unit tripping or isolation, shunt

capacitor tripping, and other automatic actions which occur during abnormal Frequency or Voltage conditions.

18.7.4. Testing

Under-Frequency Load Shedding relays shall be tested at six-monthly intervals to ensure that they are still connected and in good working order.

18.7.5. Manual Load shedding

Should the Under-Frequency Load Shedding not be sufficient, the System Operator shall shed Load manually if the System can still be saved from a Total Shutdown.

18.7.6. Re-Synchronisation

The System Operator shall shed additional Load manually before re-Synchronising the different islands after the Power System separates into various islands and there is insufficient generating capacity in the islands to restore the Power System Frequency following Under-Frequency Load Shedding.

19. SECTION: OPERATIONAL PLANNING

19.1. OBJECTIVE

19.1.1. The objective of Operational Planning is to specify technical, design, information exchange and Procedures to be applied by the System Operator to ensure proper operation of the Transmission System in the short to medium term. This also includes the studying and documentation of short and medium-term events. It shall ensure that the System Operator is prepared for short to medium term situations and emergencies. This Section describes the different technical activities necessary to ensure that Users and System Operator are well informed of the status of the System during maintenance, planned Outage and following a Forced Outage condition.

19.2. GENERAL

19.2.1. The following activities shall be performed by the System Operator to enable it to operationally plan for a stable Power System at all times:

- (a) Create a data base for:
 - (i) Steady state;
 - (ii) Sequence data; and
 - (iii) Dynamic data.
- (b) Compile a representative model for:
 - (i) Peak and minimum loading for present year; and
 - (ii) Peak and minimum loading for the next five years.
- (c) Perform load flow studies for all cases involved, checking the power flow and the Voltage profile for the existing network;
- (d) Calculate maximum and minimum fault levels at all substations on at least an annual basis;
- (e) Use the daily Demand Forecast to conduct n-1 / n-2 contingency studies to prepare for the next operational day, or any other situation in the near future. All the maintenance plans shall be studied to see the feasibility of that Outage in the next day or near future. This shall prepare the National Control Centre for any unexpected conditions that could occur. This is important considering any maintenance on major transmission lines that could be planned for the next day;
- (f) Conduct contingency studies for 2 years in advance and prepare a strategy of how to achieve the Reliability indices pursuant to Subsection 23.4
- (g) The results of the contingency studies shall be documented in a contingency plan. This plan shall be needed when the remaining lines overload or have severe Voltage depression. The contingency plan shall be studied to arrive at a

viable operational solution. The primary aim shall be to maintain supply to the Users;

- (h) In order to prepare the contingency plan, the thermal rating of all the links should be determined for the relevant areas of the network. It should also include the transformer rating and breaker breaking capacity. It is important to have information of both the 75°C and 90°C thermal limits of all the power Equipment involved;
- (i) The results shall be in the form of a load flow diagram, and the contingency plan shall consist of the load flow diagram and detailed switching instructions and precautions that should be taken prior to any operational activity;
- (j) The dynamic data shall be used to perform studies related to Voltage collapse that could occur during certain contingencies. It shall also be used to see the dynamic behaviour of the System during certain major contingencies. It can also be used to check the optimum ARC dead time for the circuits. Some of these times can be optimised and subsequently lead to the improvement of the Quality of Supply to Users;
- (k) Voltage collapse studies should also be performed using steady-state data. This shall be necessary to determine the maximum transfer across a part of the network. These studies shall indicate at what stage more expansion would be needed given the rate of consumer Load growth in a particular area;
- (l) The System Operator's Operational Planning staff shall ensure that the contingency plan documentation is in the control room and that these documents are always updated to the latest expansion of the Power System; and
- (m) System Operator's Operational Planning staff shall study the implementation of the Under-Frequency Load Shedding scheme. These studies shall be updated on at least an annual basis and the new settings and requirements shall be given to the TSP to implement as soon as possible.

19.3. FUNCTIONS OF THE OPERATIONAL PLANNING STAFF

19.3.1. The Operational Planning staff of the System Operator shall perform the following functions.

- (a) Development of plan

The System Operator shall develop a set of operational plans, which are designed to evaluate options and documented Procedures for reliable operation.

- (b) Maintenance of operational plans

The System Operator shall maintain a set of operational plans, which are designed to evaluate options and documented Procedures for reliable operation.

- (c) Plan implementation

The System Operator shall utilise the appropriate staff to implement operational plans and to assure that the System is operated reliably and securely.

(d) Information and training

The System Operator shall also ensure that the National Control Centre and the relevant Control Centre staff are well informed and trained to use this information.

(e) Reviews

The Operational Planning staff of the System Operator shall be responsible for reviewing the Under-Frequency Load Shedding scheme, as defined in Subsection 18.7.2 on at least an annual basis.

19.3.2. The Operational Planning staff shall be experienced in the operation and planning of a Power System. The required areas of expertise are the following:

(a) Technical Operational Studies

- (i) Load flows;
- (ii) Contingency studies;
- (iii) Under-Frequency studies
- (iv) Dynamic studies (Power System stability);
- (v) Voltage collapse;
- (vi) Fault level (short circuit) studies; and
- (vii) Energisation studies.

(b) Operational Documentation

- (i) System operation guidelines;
- (ii) System Operation Procedures; and
- (iii) Database creation, storage and archiving.

(c) Emergency operation and Power System restoration

The System Operator Operational Planning staff will have major inputs into the restoration plans of the System Operator as defined in Subsection 18.4.

19.4. DATA REQUIRED FOR MEDIUM TERM AND OPERATIONAL PLANNING

19.4.1. By week 32 of each Calendar year, each User shall provide the System Operator with the data requested below (except Demand solely related to Power Station Auxiliary Plant when fed in accordance with pre-agreed feeding arrangements), for the next two Calendar years.

19.4.2. Profiles

Users shall supply the following information in writing to the System Operator annually in advance:

- (a) Typical monthly maximum and minimum Demand values of the anticipated Demand per Connection Point over a year;

19.4.3. Generating Units

Users shall supply typical Active and Reactive Power profiles for their operation, and Availability as appropriate, for Generating Units under their control and for Embedded Generating Units where the total registered capacity of Generating Units on a single site exceeds 5MW. The method for submitting these data schedules for such Generating Units shall be the same as provided for in the Market Rules or other agreements with the SO.

19.4.4. On the last Business Day of every calendar week, Users shall provide the System Operator with the data requested below (except Demand solely related to Power Station Auxiliary Plant when fed in accordance with pre-agreed feeding arrangements), for the following 14 days after the submission.

19.4.5. Day-ahead Demand and Availability Forecast

- (a) Demand Forecast factors

The System Operator shall take the following factors into account when conducting Day-ahead Demand Forecasting:

- (i) Historical Demand data;
- (ii) Weather forecasts and the current and historical weather conditions;
- (iii) The incidence of major national and local events or activities that are known to the System Operator in advance;
- (iv) Transmission System losses;
- (v) Embedded Generating Units and Power Park Modules;
- (vi) Demand Control of 1 MW or more proposed to be exercised by any Distribution Network Operator and of which the System Operator has been informed;
- (vii) Other information supplied by Users; and
- (viii) Interconnection transfers.

- (b) Demand Forecast methodology

System Operator shall use a Demand Forecast methodology based on factors in Subsection 19.4.5(a) to produce, by standard utility means, unbiased forecasts of Demand including that to be met by Embedded Generating Units. Demand shall be calculated from these forecasts, but shall also take into account factors (e), (f), (g) and (h) in Subsection 19.2.1

- (c) Demand Profiles

Users shall supply the following information in writing to the System Operator 14 days in advance:

- (i) Typical weekly maximum and minimum Demand values of the anticipated Demand per Connection Point over a 14 day period;
- (d) Demand Off-takers shall supply Active and Reactive Power demand profiles by 8:00 hours on the Pre-Dispatch Day of the amount and duration of anticipated Demand Control per Connection Point that may result in a Demand change of 1 MW or more during each Dispatch Period of the Dispatch Day.
- (e) Generating Units

Users shall supply typical Active and Reactive Power profiles for their operation, and Availability as appropriate, of Generating Units under their control and those Embedded Generating Units where the total registered capacity of Generating Units on a single site exceeds 5MW. The method for submitting these data schedules for such Generating Units shall be the same as provided for in the Market Rules (or by such electronic data transmission facilities as have been agreed upon with the System Operator) or other agreements with the SO.

19.4.6. Power Park Modules

Operators of Power Park Modules shall supply the same data as required in Subsection 19.4.3 for Generating Units, with appropriate modifications unless otherwise agreed by the System Operator.

19.5. ACTUAL DEMAND CONTROL DATA

19.5.1. Off-takers shall supply the following in writing (or by such electronic data transmission facilities as have been agreed upon with the System Operator) to System Operator each day:

- (a) By 01:00hr: Active Power profiles per Connection Point for the previous Dispatch Day of the amount and duration of Demand reduction achieved from the use of Demand Control of 5MW or more (averaged over Dispatch Periods on any Connection Point), for each Dispatch Period.
- (b) by 12:00hr: Off-takers Customers shall notify System Operator of their intending Demand Control including customers demand management which may result in change of 5MW or more power on the Transmission Network.

19.6. CONNECTIONS

19.6.1. New connections

Users shall provide to the System Operator written information pertaining to new connections or additional Generation or Demand greater than 1 MW immediately when this information becomes available. This information shall include:

- (a) Anticipated connection date;

-
- (b) Location of connection;
 - (c) Size of consumers category of connection (e.g. residential, industrial etc.); and
 - (d) The typical profiles of the anticipated Generation or Demand on half hourly basis for defined categories of day type as determined by the System Operator;

19.6.2. Disconnection

Users shall provide to the System Operator written information pertaining to disconnection of existing Generation or Demand immediately and not more than 12 Calendar weeks when this information becomes available. This information shall include:

- (a) Anticipated disconnection date;
- (b) Location of connection;
- (c) Size of connection; and
- (d) The revised typical profiles of the anticipated Generation or Demand on a half hourly basis at the Connection Point for defined categories of day type as determined by the System Operator;

19.7. CHANGES TO INFORMATION ALREADY SUPPLIED

19.7.1. Changes

Users shall inform the System Operator of any changes to the information already supplied as soon as this information is available. This information shall be provided in writing, or as otherwise agreed between Users and the System Operator, such agreement not to be unreasonably withheld.

19.7.2. Monthly confirmation

The Off-takers shall confirm in writing on the 5th Business Day before the end of every month that the most recently submitted Active Power Demand profiles for the following two months are in accordance with their current best estimate of these values.

19.7.3. Weekly Confirmation

Users shall confirm in writing on the last Business Day of every week that the most recently submitted data profiles for the following 14 days are in accordance with their current best estimate of these values.

19.8. TIMING AND PUBLICATION

19.8.1. The System Operator shall provide a day ahead Demand forecast, a day ahead forecast of Power Park Modules, and resulting Residual Load forecast for the Transmission System each Pre-dispatch Day by 11:00 for each Dispatch Period for the next Dispatch Day. This information shall be provided by being posted in the System Operator Website or other agreed medium and shall be in a format reasonably determined by the System Operator and Users as being suitable.

19.8.2. The Demand Forecast shall include Transmission System losses.

20. SECTION: INFORMATION EXCHANGE

20.1. OBJECTIVE

20.1.1. The objective of this Section is to provide for the exchange of information so that the implications of an Operational error and/or Power System Event can be considered. The possible risks must be assessed and appropriate action taken by the relevant party in order to assist in maintaining a secure Power System. The correct information needs to be identified and communicated to the correct structures in the Nigerian Electricity Supply Industry.

20.2. GENERAL

20.2.1. This Section sets out the requirements for the exchange of information particularly in relation to Operations and/or events on the Power System, which have had or shall have an operational effect, and thereby have become Power System incidents (being an “Abnormal Operation” or an “Event”):

- (a) On the Transmission System in the case of an Abnormal Operation and/or Event occurring on a User’s System; and
- (b) On a User’s System in the case of an Abnormal Operation and/or Event occurring on the Transmission System.

20.2.2. The System Operator shall report any Event or Abnormal Operation on the Transmission System to all Users. This notification is expected to report what shall happen or what has happened on the Power System.

20.2.3. The System Operator shall have information available for System incident analyses by means of:

- (a) The System Operator’s SCADA system(s) and other data collection systems; and
- (b) Information provided to the System Operator by Users under other Subsections of this Code.

20.3. REQUIREMENT TO NOTIFY

20.3.1. The System Operator, Transmission Service Provider and the Users shall agree to review from time to time which Abnormal Operations and Events shall be required to be notified.

20.4. NOTIFICATION OF AN ABNORMAL OPERATION

20.4.1. The System Operator shall establish and implement operating instructions, Procedures, standards and guidelines to cover the operation of the network under normal and abnormal conditions.

20.4.2. The System Operator shall notify all Users of any Abnormal Operations on the Transmission System, which shall have, in the reasonable opinion of the System Operator, an operational effect on any User.

20.4.3. The System Operator may proceed with urgent operations without notifying all Users and without the required procedures. This can only be done if it is of a temporary nature and less than 15 minutes. The System Operator shall notify all Users of any operations on the Transmission System without any delay as soon as the System has been restored to normal. The System Operator shall also inform the Users as to the likely duration of the condition and shall update this prognosis as appropriate. The System Operator shall additionally inform the Users as soon as reasonably possible when the condition has ended.

20.4.4. The User shall notify the System Operator of Abnormal Operations on the User's System, which shall have an operational effect on the Transmission System. The System Operator shall notify any Users on whose System(s) the Abnormal Operation shall have an operational effect.

20.5. FORM OF NOTIFICATION OF AN ABNORMAL OPERATION

20.5.1. A notification of an Abnormal Operation shall be of sufficient detail to describe the Abnormal Operation and to enable the recipient of the notification to reasonably consider and assess the implications and risks arising.

20.5.2. A notification shall include the name of the individual reporting the Abnormal Operation on behalf of the System Operator or the User, as the case may be.

20.5.3. The recipient of the notification may ask questions to clarify the notification and the System Operator or the User shall answer any questions raised.

20.6. RECORDING OF AN ABNORMAL OPERATION

20.6.1. The notification shall be given in writing whenever possible before carrying out an Abnormal Operation. The notification shall be given orally if there is insufficient time before the operation is scheduled to take place for notification to be given in writing. If either the User or the System Operator requests it, it shall be submitted as soon as possible, after the System has returned to normal, in writing.

20.6.2. The System Operator shall maintain a database of notifications on the System.

20.7. TIMING IN RESPECT OF AN ABNORMAL OPERATION

20.7.1. A notification shall be given as far in advance as possible and in any event shall be given in sufficient time as will reasonably allow the recipient to consider and assess the implications and risks arising.

20.8. NOTIFICATION OF EVENTS

20.8.1. The System Operator shall notify the Users of Events which in the reasonable opinion of the System Operator are significant System incidents having an operational effect on the Users.

20.8.2. The Users shall notify the System Operator of Events which may be significant System incidents affecting the Transmission System. The System Operator may use this information in notifying any other Users of the Event.

20.9. FORM OF NOTIFICATION OF AN EVENT

20.9.1. A notification of an Event shall describe the Event clearly. The information shall be of sufficient detail to enable the recipient of the notification to consider and assess the implications and risks arising.

20.9.2. A notification shall include the name of the individual reporting the Event on behalf of the System Operator or the User, as the case may be.

20.9.3. The recipient of the notification may ask questions to clarify the notification and the System Operator or the User shall answer any questions raised.

20.10. PROVISION OF FURTHER INFORMATION

20.10.1. The System Operator shall provide additional information to a User after the User has reported an Event. The User may request the fault level at the time of the incident to perform more accurate assessments following an Event.

20.11. RECORDING OF AN EVENT

20.11.1. Notification of an Event shall be given orally in the first instance. Significant System incidents must be reported in writing if requested by either the User's or the System Operator.

20.11.2. The System Operator shall maintain a database of Events on the System.

20.12. TIMING IN RESPECT OF AN EVENT

20.12.1. A notification of an Event shall be given as soon as practicable after the occurrence of the Event. A notification of an Event shall be given within fifteen minutes, except in an emergency.

20.13. OPERATIONAL COMMUNICATION AND DATA RETENTION

20.13.1. It is necessary that adequate communication facilities and procedures be established between the System Operator and Users to allow for the timely transfer of information, in

order that the System Operator may fulfil its obligations with regard to the operation of the Transmission System.

20.13.2.The objectives are:

- (a) To establish contact locations for the System Operator and each class of User;
- (b) To detail the communication facilities required between the System Operator and each class of User;
- (c) To establish the Procedure for communication of information between the System Operator and Users;
- (d) To establish the Procedure for the authorisation of the System Operator personnel to act on behalf of the System Operator, and User's personnel to act on behalf of the Users in the communication of information between the System Operator and Users; and
- (e) To establish the general procedures for the retention of data.

20.13.3.Both the System Operator and Users shall be obliged to adopt the use of new technologies and methodologies for communication of information, where there is a recognisable benefit from doing so, and to do so would be reasonable in the circumstances.

20.14. CONTACT LOCATIONS

20.14.1.The System Operator

The contact location within the System Operator for communication on matters pertaining to the real-time operation of the Transmission System shall be the National Control Centre (NCC) or if designated the Back-up Control Centre.

The System Operator shall, from time to time, notify all the Users of the relevant details for contacting the System Operator.

The System Operator shall, from time to time, distribute to each User an organisational chart and list of personnel and contact numbers in order to assist the Users in communicating with the System Operator.

20.14.2.Generators

The Generators' contact locations and personnel shall be notified to the System Operator by the Generator prior to connection and thereafter it shall be updated as appropriate.

The Generator shall be required to provide a control Facility (control room to control the Power Station). The Generator shall ensure by acting in accordance with Good Utility Practice that the control Facility is staffed at appropriate staffing levels at all times.

The control Facility shall be staffed by a responsible operator(s) who shall respond to communications from the System Operator without undue delay. The operators shall be of suitable experience and training and shall be authorised to perform the following functions on behalf of the Generator:

-
- (a) To accept and execute Dispatch Instructions; and
 - (b) To receive and acknowledge receipt of requests, for amongst other matters, operation outside the registered values of Availability, Ancillary Service capability, or operating characteristics of the Generating Units / Power Park Modules during System Emergency Conditions as stipulated in Appendix 8.

At any point in time, a single person shall be designated as the Responsible Manager by the Generator and notified to the System Operator. The Responsible Manager shall be responsible for dealing with the System Operator on matters relating to the Grid Code. In the event that the Responsible Manager is not a person on duty at the control Facility, then the Responsible Manager must be capable of being contacted from the control Facility at all times. In the event that the System Operator issues a request to the control Facility requiring the Responsible Manager to contact the NCC, the Responsible Manager shall comply with the request without undue delay and in any case within 15 minutes of the request.

The Responsible Manager shall be authorised by the Generator to perform the following functions on behalf of the Generator:

- (a) To make estimates in accordance with Good Utility Practice as to the Availability, Ancillary Service capability and operating characteristics of each Generating Unit or Power Park Module;
- (b) To make declarations for each Generating Unit or Power Park Module; and
- (c) To communicate with respect to issues regarding Outages of each Generating Unit or Power Park Module.

The Generator may, from time to time, notify a replacement contact location and personnel, which meets the foregoing requirements.

The control facility of Power Park Module may or may not be at the same location as the Power Park Module itself. In the case that it is at a different location, then an appropriate communication link between the control facility and the Power Park Module must be designed, installed and maintained by the Generator. This communication link must allow remote control of the Power Park Module(s) with a time delay of less than 1 second.

20.14.3. Directly Connected Customers

The Directly Connected Customer shall notify the System Operator of its contact locations and the detail of its personnel prior to connection and thereafter it shall be updated as appropriate.

The Directly Connected Customer is required to provide the System Operator with the contact information of a responsible operator(s) who shall respond to communications from the System Operator without undue delay. The operators shall be of suitable experience and training and shall be authorised to perform functions on behalf of the Directly Connected Customer.

The responsible operator shall have the ability to attend to the site of the Directly Connected Customer within 60 minutes of an instruction being issued by the System Operator.

At any point in time, the Directly Connected Customer shall notify the System Operator of a single person designated by the Directly Connected Customer as the Responsible Manager. The Responsible Manager shall be responsible for dealing with the System Operator on matters relating to the Grid Code. In the event that the Responsible Manager is not a person on duty at the site of the Customer Connected to the Transmission System, then the Responsible Manager must be capable of being contacted from the site of the Directly Connected Customer at all times. In the event that the System Operator issues a request to the site of Directly Connected Customer requiring the Responsible Manager to contact the NCC, the Responsible Manager shall comply with the request without undue delay and in any case within 60 minutes of the request.

20.14.4. Distribution Network Operators

The Distribution Network Operator shall notify the System Operator of its contact locations and the detail of its personnel prior to connection and thereafter it shall be updated as appropriate.

The Distribution Network Operator shall be required to provide a control Facility.

The Distribution Network Operator shall ensure by acting in accordance with Good Utility Practice that the control Facility is staffed at appropriate staffing levels at all times.

The Distribution Network Operator shall operate its control Facility according to the provisions agreed upon with the System Operator as set out in the Distribution Network Operator's and the System Operator agreement.

20.15. COMMUNICATION FACILITIES

20.15.1. All communication facilities to be provided shall be in accordance with the provisions of this Code.

20.15.2. All Equipment to be provided by the Users shall comply with the applicable International Telecommunications Union (ITU) and International Electrotechnical Commission (IEC) standards. This shall apply for SCADA and communications Equipment and shall meet such standards as notified in advance by the System Operator of their design or procurement and shall be provided at the cost of the Users, except where otherwise specified.

20.16. SUPERVISORY CONTROL AND DATA ACQUISITION (SCADA)

20.16.1. SCADA Remote Terminal Units shall be required in all the control rooms of the System Operator and at the Off-taker's boundary site and the Generator's control room for the transmission of signals and indications to and from the NCC. The signals and indications, which must be provided by Users for transmission by SCADA Equipment to the NCC, shall be the signals and indications as agreed to by the System Operator and may from time to time be changed by agreement.

20.16.2.Interface cabinets shall be installed in the relevant control room and the User shall provide and maintain wiring and signalling from the User's Plant and Apparatus to the interface cabinet. In the case of the System Operator RTUs the TSP shall take this responsibility.

20.17. COMPUTER EQUIPMENT

20.17.1.Each User shall comply with the System Operator requirements and provide appropriate computer and data networking Equipment to allow data exchange, such as electronic mail, Dispatch Instructions etc. between the System Operator and the User. The User shall only use this Equipment for operational communications with the System Operator.

20.17.2.Each User shall be responsible for optimising the Reliability and security of the computer Equipment including the provision, at no charge, of an uninterruptible power supply.

20.18. TELEPHONE

20.18.1.Each User shall be responsible for the provision and maintenance of telephone Equipment.

20.18.2.The System Operator shall provide one or more telephone extension to be connected to the System Operator private operational telephone system. This Facility shall be reserved for operational purposes only, and shall be attended continuously by an authorised operational person and answered without undue delay. Users shall be responsible for optimising the Reliability and security of this telephone service including the provision at no charge of an uninterruptible power supply.

20.18.3.Users shall provide a public switched telephone network circuit to the communications and control room.

20.18.4.Users shall provide no less than two separate public switched telephone network circuits to the control Facility.

20.19. ACCESS AND SECURITY

20.19.1.All SCADA, metering Equipment, computer and communications Equipment that interfaces with the System Operator, and the information carried by it must be secured against unauthorised access. Procedures governing security and access shall be agreed with the Users in the operation instructions, but shall allow for adequate access to the Equipment and information by the System Operator for the purposes of maintenance, repair, testing and the taking of readings.

20.20. TIME STANDARDS

20.20.1. Time shall be set by a standard determined by the System Operator. The time standard shall be broadcast to relevant telecommunications devices in order to maintain time coherence.

20.21. COMMUNICATION BETWEEN THE USERS

20.21.1. Communication between the System Operator, the Users on matters pertaining to the real-time operation of the Transmission System shall take place between the NCC and the User's control Facility, unless where specifically provided for in other Sections of this Code.

20.21.2. The System Operator shall ordinarily notify the Users as soon as practicable after the decision to move the NCC to a different location. This shall be no less than seven (7) days prior to the move, but in the event of an emergency it may instead notify them as soon as practicable after the move.

20.21.3. All instructions given by NCC and communications between NCC and the User's control facilities shall be given by means of the specified communication facilities, unless otherwise specified in the Grid Code.

20.21.4. The System Operator and the Users shall accept any automatic recording of communications given by means of telephony or electronic means, as evidence of instructions or communications.

20.22. DATA AND NOTICES

20.22.1. Data and notices shall be submitted in accordance with relevant rules and procedures.

20.22.2. Data and notices to be submitted to the System Operator or to the Users, under the Grid Code shall be in writing and shall be delivered by hand or sent by pre-paid post or receipted email.

20.22.3. Data and notices to be submitted to the System Operator under the Grid Code shall be addressed to the person, and at the address, notified by the System Operator to the Users for such purpose in their respective Agreements.

20.22.4. Data and notices to be submitted to the Users under the Grid Code shall be addressed to the Users representatives as nominated in the Agreements. Or to such other person or address as the Users may notify to the System Operator from time to time.

20.22.5. All data items, where applicable, shall be referenced to nominal Voltage and Frequency unless otherwise stated.

20.22.6. All operational data shall be supplied in accordance with the timetables as set out in the Grid Code.

20.23.DATA RETENTION

20.23.1.This provision has to be read in conjunction with the Market Rules to form the complete requirement with regard to data retention.

20.23.2.Operational data is all data to be supplied by Users under this Code and any other data expressly provided to be operational data under this Code. Operational data to be supplied by the Users shall be submitted to the department or address as the System Operator may from time to time advise.

20.23.3.The Users shall keep all operational data confidential.

20.23.4.System Operator shall maintain a complete and accurate record of all operational data supplied or maintained under the Grid Code. The format for the retention of records shall be as the System Operator may reasonably determine. All operational data shall be maintained for a period of no less than three (3) years commencing from the date the operational data was first supplied (or first created, if earlier).

20.23.5.The System Operator shall allow the Users access to its records (and copies thereof) of operational data and/or data required to be maintained, on reasonable notice.

21. SECTION: SCHEDULING AND DISPATCH

21.1. OBJECTIVE

21.1.1. The objective of this Section is to provide Generators with provisional running orders for the Dispatch Day ahead, such that Generating Units will be made available in the correct timescale to enable the System Operator to Dispatch them whilst maintaining the required Operating Reserve. In order to achieve the primary objective, this Section details the timescale for the System Operator to make specific information available to Generators and other Users.

21.1.2. A further objective of this Section is to establish a framework to enable the System Operator to issue Dispatch Instructions to:

- (a) Generators with respect to their Generating Units and / or Power Park Modules; and
- (b) Users in relation to Ancillary Services.

21.1.3. Dispatch Instructions are primarily issued such that available Generation is matched to Demand with appropriate margin of Operating Reserve whilst maintaining the integrity and security of the Transmission System with acceptable Quality of Supply.

21.2. GENERAL

21.2.1. The System Operator shall dispatch Generating Units according to Market Rules, subject to constraints of safety of personnel, Equipment, System Security, System Stability, Reliability and the environmental requirements.

21.2.2. The Dispatch of Generating Units is necessary to ensure that the most economical combination of Generating Units and / or Power Park Modules possible is used for each Dispatch Period. This optimal combination of Generating Units and / or Power Park Modules must meet the Demand such that the necessary Frequency Control can be achieved.

21.2.3. In order to achieve this, the System Operator will have to calculate the optimal combination of Generating Units on a continuous basis using specialised software suitable for this. These calculations by the System Operator are based on Day-ahead Nominations from Generators for each Generating Unit and the anticipated Demand, and anticipated Power Park Module Active Power output.

21.2.4. Due to the free fuel costs for Power Park Modules, this type of generation will typically be given priority access to generate onto the System unless other events, for example System conditions or System constraints or other must run requirements prevail.

21.3. DATA AND PROCESS

21.3.1. The System Operator shall forecast the Power System Demand, and the total Power Park Module Active Power output, in accordance with Subsection 19.4.5 that shall be used in the Dispatch process.

21.3.2. System Operator shall set the level of Reserve that shall be used in the Dispatch process.

21.3.3. System Operator shall include in the Dispatch Instructions the Active Power Output level of a Generating Unit or Power Park Module, Synchronising or De-synchronising time, if appropriate and Ancillary Services to be provided.

21.3.4. System Operator shall adjust Generating Unit or Power Park Module Active Power Output by using a merit order based (this may be manual or by using specialist software) on the Day-ahead Nominations provided by Generators for each Generating Unit or Power Park Module as variations occur due to such factors as Demand or Availability variations.

21.4. DISPATCH SCHEDULING

21.4.1. Production of a Dispatch Schedule

Each day between 13:00 hours and 16:00 hours the System Operator shall produce the two Dispatch Schedules pursuant to Subsections 21.4.2 and 21.4.3 for the Dispatch Day. The System Operator may produce the Dispatch Schedule more or less frequently, or reasonably delay its production in response to changes in Availability and other events that may arise. The Dispatch Schedule is utilised by the System Operator in its scheduling and in its preparation for Dispatch of Generating Units or Power Park Modules.

In preparing the Dispatch Schedule, the System Operator shall schedule Day-ahead Nominations to minimise the offered cost of meeting Load forecast according to the principles set out in Subsection 23.3, taking into account the following factors:

- (a) Forecast Demand and geographical Demand distribution, plus a Forecast of Power Park Modules;
- (b) Generating Units' or Power Park Modules' Registered Information, including operating characteristics, Ancillary Service capability and Availability;
- (c) Generator Day-ahead Nominations, including Nominations by Hydro Generating Units;
- (d) Declared abnormal risks to Generating Units or Power Park Modules;
- (e) Ancillary Service requirements, including Frequency Control, Operating Reserve and Voltage Control;
- (f) Reliability Must-run requirements;
- (g) Transmission System constraints, including Network and Generating Unit or Power Park Module constraints;

-
- (h) Transmission System losses;
 - (i) System Operator and Users' monitoring and test requirements;
 - (j) Transmission System stability implications;
 - (k) Interconnector Capacity Entitlements and Interconnector Energy Trade Nominations pursuant to Rule 25 of the Market Rules;
 - (l) Interconnection Agreements;
 - (m) Other factors as may be reasonably considered by the System Operator to be relevant to the Dispatch Schedule.

21.4.2. Pre-dispatch Day constrained Schedule

The System Operator shall produce a Pre-dispatch Day constrained Schedule for each Dispatch Day by 16:00 hours on the Pre-dispatch Day.

The System Operator shall issue provisional running orders based upon the Dispatch Schedule for the Dispatch Day to the Generator for each Generating Unit or Power Park Module by 16:00 hours on the Pre-dispatch Day.

The provisional running orders issued to each Generating Unit or Power Park Module by the System Operator, shall indicate the planned Generating Unit or Power Park Module Active Power Output pattern specifying:

- (a) Forecast start-up and shut-down times, if relevant;
- (b) Forecast Active Power Dispatch levels for each Dispatch Period; and,
- (c) Forecast levels of Operating Reserve provision for each Dispatch Period, if the Generating Unit or Power Park Module is contracted for Operating Reserve requirements.

Provisional running orders are indicative only, provided as a guide to the expected output requirements from Generating Units or Power Park Modules and are not Dispatch Instructions.

21.4.3. Pre-dispatch Day unconstrained Schedule

The System Operator shall produce a Pre-dispatch Day unconstrained Schedule for each Dispatch Day by 16:00 hours on the Pre-dispatch Day. The same principles specified in Condition 21.4.1 shall be applied with the following change:

- (a) The known Transmission System constraints must be excluded.

This Schedule shall be used to forecast the Day-ahead Price consistent with the appropriate Market Rules.

21.4.4. Dispatch Day schedule

If the System Operator forecasts a significant difference between the provisional running orders and anticipated Dispatch Instructions, in the interval between the issue of provisional running orders and the issue of relevant Dispatch Instructions, the System Operator shall endeavour to notify this difference to impacted Generators.

21.4.5. System congestion

System Operator shall install and commission such real time Equipment and software as to calculate Transmission Constraints and Reliability margins per Dispatch Period.

System Operator shall change the Dispatch Schedule of the Generating Units in order to eliminate Transmission System congestion and to ensure the security and Reliability of System operation.

System Operator shall limit the production of Power Park Modules if it was not possible to eliminate congestion by changing the Dispatch of the (Dispatchable) Generating Units.

System Operator shall reduce the Load in the importing region contributing to the congestion if it was not possible to eliminate congestion by changing the Dispatch of the Generating Units, or by limiting the production of Power Park Modules.

System Operator shall further instruct all Users to take specific action in order to avoid more major disturbances in emergency situations.

21.4.6. Ex-post Unconstrained Dispatch Schedule

The System Operator shall produce an Ex-post Unconstrained Dispatch Schedule for each Dispatch Day by no later than 12:00 hours on the Calculation Day. This leaves the System Operator sufficient time to calculate the System Marginal Price for each Dispatch Period pursuant to Rule 33.2 of the Market Rules. The same principles specified in Subsection 21.4.1 shall be applied with the following two changes:

- (a) The actual Load readings must be used; and
- (b) The Transmission System constraints must be excluded.

21.5. GENERATION DISPATCH

21.5.1. Dispatch Instructions to Generators

The System Operator shall issue Dispatch Instructions relating to the Dispatch Day at any time during the period beginning immediately after the issue of the Dispatch Schedule in respect of that Dispatch Day.

The System Operator shall give a Dispatch Instruction to a Generator for a specific Generating Unit or Power Park Module to change the output of Active Power, Reactive Power or an instruction to provide an Ancillary Service.

The System Operator shall give Dispatch Instructions to a Generator orally, by phone or by electronic means including by means of Automatic Generation Control. The Dispatch Instruction shall identify the relevant Generating Unit or Power Park Module by specifying the Generator's and Generating Unit's or Power Park Module's unique identification number pursuant to Rule 15.5.1 of the Market Rules.

A Generator shall immediately and formally acknowledge a Dispatch Instruction in respect of a Generating Unit or Power Park Module by telephone, or immediately provide a reason for

non-acceptance. The reason for non-acceptance shall only be on safety grounds (relating to personnel or Plant) or because the Dispatch Instruction is not in accordance with the Nomination or the Registered Information relevant to the time and period to which the Dispatch Instruction relates.

The System Operator shall be notified without delay by telephone in the event that in carrying out the Dispatch Instruction, an unforeseen problem arises, caused on safety grounds (relating to personnel or Plant).

The System Operator shall maintain a record of all daily Dispatch Instructions issued to Generators.

21.5.2. Generation Synchronising and De-synchronising Times

The System Operator shall determine the required Synchronising and De-synchronising times for Generating Units or Power Park Modules.

The System Operator shall issue Dispatch Instructions to Generators to Synchronise (or De-synchronise) specific Generating Units or Power Park Modules in accordance with their Registered Information.

If a Dispatch Instruction to a Generator to Synchronise a specific Generating Unit or Power Park Module does not also contain an Active Power Output to be achieved then it shall be assumed that the instruction is to increase output (following Synchronisation) up to the level of minimum generation of the Generating Unit or Power Park Module as specified in the Registered Information.

Where a Synchronising time is issued by the System Operator to a Generator for a specific Generating Unit or Power Park Module and the Generator identifies that the Generating Unit or Power Park Module will not be Synchronised within +/- 10 minutes of the instructed time, the Generator shall immediately (at the time the discrepancy is identified) inform the System Operator of the situation and the estimated new Synchronising time.

The allowable tolerance appropriate to Synchronising times shall be based on the times set out in the Registered Information.

21.5.3. Generation Active Power Dispatch

Based on the Day-ahead Nominations of the Generators, on System conditions, and on other factors as may arise from time to time, the System Operator shall issue Dispatch Instructions to a Generator in relation to a specific Generating Unit or Power Park Module, which has been instructed to be Synchronised, to adjust its Active Power Output.

When a Generator has received and accepted a Dispatch Instruction for a Generating Unit or Power Park Module to change the level of Active Power, it shall without delay adjust the level of output of the Generating Unit to achieve the new target in line with its Registered Information and its Quantity Nomination.

A Generating Unit or Power Park Module shall be deemed to have complied with a Dispatch Instruction when it achieves an output within the allowable tolerance as specified in Rule 27.5 of the Market Rules. Deviations outside the allowable tolerance band will be treated according to Rule 27.5 of the Market Rules.

The adjustment of Active Power Output of a Generating Unit or Power Park Module operating in a Frequency sensitive mode for System Frequency other than an average of 50Hz, shall be made in accordance with the current registered value of Governor Droop for the Generating Unit or Power Park Module.

The System Operator shall be notified immediately by telephone in the event that while carrying out the Dispatch Instruction an unforeseen problem arises caused by safety reasons (relating to personnel or Plant).

Note that Active Power of Power Park Modules cannot be set but only be limited. Therefore, Dispatch Instructions for Active Power shall be interpreted as maximum Active Power Limits. In normal operation, Power Park Modules should be permitted to produce up to their maximum instantaneous Active Power generation. Only when System security requires that Power Park Modules must operate in Constraint Operation, they must follow the corresponding instructions of the System Operator (see also Subsection 21.5.8).

When a Power Park Module has received and accepted an instruction to limit the level of Active Power, it shall without delay apply the Active Power limitation at its Connection Point.

21.5.4. Generator Reactive Power Dispatch

The System Operator shall issue Dispatch Instructions to Generators to adjust the Reactive Power output of any Generating Unit or Power Park Module that has been instructed to be Synchronised.

- (a) A Generator shall be able to provide Reactive Power within the Generating Unit or Power Park Module Capability Chart. The System Operator shall control the amount of Reactive Power.
- (b) For the avoidance of doubt the MVAR instruction may be to maintain a specific Voltage utilising the Automatic Voltage Regulator. Where this Voltage target cannot be achieved by the Generator due to its MVAR limits it shall inform the System Operator. In the case of a Power Park Module, the instruction may be to respond accordingly to a specific Voltage target and droop characteristic, a constant power factor characteristic (including a unity power factor instruction), a specific Q(P) Control characteristic, or a constant MVAR characteristic, all applied at the Connection Point.
- (c) Voltage Control and the supply or consumption of Reactive Power are inter-related in the sense that the Voltage is affected by changes in the Reactive Power flow. System stability depends on the Voltage profile across the System. In view of these considerations it is necessary from time to time to employ certain Power Stations to supply or consume Reactive Power, whether or not they are producing Active Power, for the purpose of Voltage Control.

The Reactive Power output of any Generating Unit or Power Park Module in respect of which a Dispatch Instruction is given shall then, without delay be adjusted in accordance with its Registered Information, to the new target Reactive Power so instructed, within, a tolerance of +/- 2% of the target or +/- 2MVAR whichever is greater. The Reactive

Power output of a Generating Unit or Power Park Module shall not be adjusted (other than under AVR or other automatic control action as detailed in (b) above) other than in response to a Dispatch Instruction from the System Operator.

Generators having achieved the new target Reactive Power output should not attempt to sustain this level of Reactive Power output as the System Voltage varies but should, rather, allow the Reactive Power output to vary under AVR or other automatic control methodology as detailed in (b) above control in accordance with registered Ancillary Service capabilities in the Registered Information.

While a Reactive Power Dispatch Instruction shall normally specify a new Reactive Power target for a Generating Unit, the System Operator may also from time to time instruct Generators to perform one or more tap changes on the Generating Unit step-up transformer of a Generating Unit if it has on-load tap-change capability. The instruction for tap changes may be a simultaneous tap change instruction whereby the tap change shall be effected by the Generator in response to an instruction from the System Operator issued simultaneously to relevant Power Stations. The instruction, which is normally preceded by advance warning, shall be effected within 1 minute of receipt from the System Operator of the instruction. For the avoidance of doubt, this does not apply to Power Park Modules as the point of Voltage Control is at the Connection Point located at HV. Tapping of internal Power Park Module transformers should therefore be automatically managed by the Generator to ensure that the full reactive capability of the Power Park Module is available at the Connection Point.

Where a Generating Unit has off-load tap-change capability the SO shall before it Synchronises instruct it to the appropriate tap position.

- a. Where the SO does not give such instruction, the Generator shall request the SO to give this instruction.

Dispatch Instructions in relation to Reactive Power shall include target Voltage levels to be achieved by the Generating Unit on the Transmission System at the Connection Point (or on the Off-taker System at the Off-taker System Entry Point in the case of an Embedded Generating Unit) namely on the higher Voltage side of the Generating Unit step-up transformer). Where a Generating Unit is instructed to a specified target Voltage, the Generator shall achieve that target within a tolerance of 1 kV by tap changing on the Generating Unit step-up transformer unless otherwise agreed with the System Operator. Under normal operating conditions, once this target Voltage level has been achieved, the Generator shall not tap change again without prior consultation with and agreement of the System Operator.

Under certain conditions such as low System Voltage, an instruction to maximum Reactive Power output at instructed Active Power Output shall be given and the Generator shall take appropriate action to maximise Reactive Power output unless constrained by Plant operational limits or safety grounds relating to personnel or Plant.

Under certain conditions such as high System Voltage, a Dispatch Instruction to maximum Reactive Power absorption at instructed Active Power Output shall be given and the

Generator shall take appropriate action to maximise Reactive Power absorption unless constrained by Plant operational limits or safety grounds relating to personnel or Plant.

The issue of Dispatch Instructions for Active Power shall be made with due regard to any resulting change in Reactive Power capability and shall include reduction in Active Power Generation in order to increase Reactive Power capability (i.e. take account of the Generating Unit or Power Park Module Capability Chart).

The excitation system of a Generating Unit, unless otherwise agreed with the System Operator, shall be operated only in its constant terminal Voltage mode of operation with Reactive Power limiters in service, with any constant Reactive Power output control mode or constant power factor output control mode always disabled, unless agreed otherwise with the System Operator. In the event of any change in System Voltage, a Generator shall not take any action to override automatic Reactive Power response which is produced as a result of constant terminal Voltage mode of operation of the automatic excitation control system unless instructed otherwise by the System Operator or unless immediate action is necessary to comply with stability limits or unless constrained by Plant operational limits or safety grounds (relating to personnel or Plant).

The Voltage Control / Reactive Power Control system of a Power Park Module, shall be designed such that operation at extremes of its capability chart for indefinite periods of time shall not cause the Power Park Module to trip. In the event of any change in System Voltage, a Generator shall not take any action to override the Voltage Control / Reactive Power Control systems unless instructed otherwise by the System Operator or constrained by Plant operational limits or safety grounds (relating to personnel or Plant).

A Dispatch Instruction relating to Reactive Power shall be implemented without delay and will be achieved not later than 2 minutes after the instruction time, or such longer period as the System Operator may instruct.

Where Dispatch Instructions relating to Active Power and Reactive Power are given together, and to achieve the Reactive Power output would cause the Generating Unit or Power Park Module to operate outside its Capability Chart as a result of the Active Power instruction being met at the same time, then the timescale of implementation of the Reactive Power instruction shall be extended to be no longer than the timescale for implementing the Active Power instruction but in any case to achieve the Reactive Power Dispatch Instruction as soon as possible.

For Power Stations with on-load tap change capability:

- a) In circumstances where the System Operator issues new instructions in relation to more than one Generating Unit at the same Power Station at the same time tapping shall be carried out by the Generator one tap at a time either alternately between (or in sequential order, if more than two), or at the same time on, each Generating Unit, as the case may be.
- b) Where the instructions require more than two taps per Generating Unit meaning that the instructions cannot be achieved within 2 minutes of the instruction time, (or such longer period at the System Operator may have instructed), the

instructions shall each be achieved with the minimum of delay after the expiry of that period.

- c) On receiving a new Active Power Dispatch Instruction, no tap changing shall be carried out to change the Reactive Power output unless there is a new Reactive Power Dispatch Instruction.

Where an instruction to Synchronise is given, or where a Generating Unit or Power Park Module is Synchronised and an Active Power Dispatch Instruction is given, a Reactive Power Dispatch Instruction consistent with the Generating Unit's or Power Park Module's relevant parameters shall be given. In the absence of a Reactive Power Dispatch Instruction with an instruction to Synchronise, the Reactive Power output should be 0 MVAR.

Where an instruction to De-synchronise is given, a Reactive Power Dispatch Instruction, compatible with shutdown, shall be given prior to De-synchronisation being achieved. In the absence of a separate Reactive Power Dispatch Instruction, it is implicit in the instruction to De-synchronise that Reactive Power output should at the point of Synchronism be 0 MVAR at De-synchronisation.

It should be noted that should System conditions require, the System Operator may need to instruct maximum Reactive Power output to be achieved as soon as possible, but in any event no later than 2 minutes after the instruction is issued.

On receipt of a Dispatch Instruction relating to Reactive Power, the Generator shall take such action as is necessary to maintain the integrity of the Generating Unit or Power Park Module (including, without limitation, requesting a revised Dispatch Instruction), and shall contact the System Operator without delay.

Reactive Power Dispatch Instructions issued by the System Operator shall reflect the limits contained in the Registered Information regarding Ancillary Service capabilities and Quantity Nominations.

Under System fault conditions it is possible for AVR action to drive Reactive Power output for a Generating Unit outside of its limits as contained in its Registered Information. The Generator shall immediately inform the System Operator of the situation. However if the Generator reasonably believes that the situation may be dangerous to personnel or Plant, then limited action shall be taken to improve the situation following which it must inform the System Operator.

Under System fault conditions it is possible for automatic Voltage or Reactive Power Control functions to drive the Reactive Power output for a Power Park Module to, or potentially outside of its Capability Chart. In this case the Generator shall immediately inform the System Operator of the situation. However if the Generator reasonably believes that the situation may be dangerous to personnel or Plant, then limited action shall be taken to improve the situation following which it must inform the System Operator.

21.5.5. System alerts

The System Operator shall notify Generators, by one of several means, of the existence of a System Emergency Condition.

21.5.6. System Emergency Conditions

The System Operator may instruct Generators to operate outside the limits implied by the then current Registered Information in order to maintain Transmission System integrity under System Emergency Conditions.

Where the System Operator has issued an emergency instruction requiring operation of a Generating Unit or Power Park Module outside the limits applied by the then applicable Quantity Nomination and Registered Information, then the Generator shall comply with the emergency instruction if, in the reasonable opinion of the Generator, the safety of personnel, and/or Plant is not compromised in complying with the request.

21.5.7. Failure to Comply with a Dispatch Instruction

The Generator shall inform the System Operator by telephone without delay if at any time a Generating Unit or Power Park Module is unable to comply with any Dispatch Instruction correctly issued by the System Operator in respect of any Generating Unit or Power Park Module.

21.5.8. Constrained Generation

Constrained generation is the service supplied by a Generator at one of its Power Stations to the System Operator by constraining its power output below (alternatively above) the unconstrained schedule level. The service is required to ensure that the Transmission Network remains between appropriate operational limits (e.g. thermal, Voltage or stability limits).

If in providing the service, the Generator experiences a financial loss, for which it shall be compensated by the Transmission Service Provider according to the Market Rules. Constrained generation is required to meet network Reliability as there are no current rules for market splitting across transmission constraints or the handling of Generating Units in strategic positions.

The identification of the specific Transmission Network constraints applicable at any point in time shall be the responsibility of the System Operator.

22. SECTION: OUTAGE COORDINATION

22.1. OBJECTIVE

22.1.1. The objective of this Section is to define the obligations for formal notification of Outages by Users and TSP to the System Operator.

22.2. GENERAL

22.2.1. Secure operation of an electricity System requires that the maintenance of the Generating Units or Power Park Modules should be coordinated with the Outages of critical Transmission lines. This is essential in order to enable the System Operator to fulfil its obligations relating to the operation of the Transmission System, and to enable Users and TSP to plan their Outages in an orderly way. The mechanisms by which this is achieved will be formalised in this Section.

22.3. OUTAGE SCHEDULING

22.3.1. The System Operator and Users and TSP shall establish schedules for inspection and preventive maintenance of their Generation, Distribution, Transmission, protection, control, communication and other Auxiliary Equipment. These maintenance and inspection schedules shall be coordinated to ensure an Equipment Outage pattern that shall not violate Power System Reliability and minimise customer disturbance.

22.3.2. Planning and co-ordination

The System Operator shall coordinate all Outage plans for the Users and TSP, on an annual basis. These plans shall be ready by October of every year. The System Operator shall then be responsible for performing pertinent Reliability studies to ensure the secure operation of the Power System during the Outages as have been agreed in the annual Outage plans.

Scheduled Generation and Transmission Outages that may affect the Reliability of Power System operations shall be planned and coordinated (notification of cancellation at least 24 hours in advance) amongst the affected parties. Special attention shall be given to the results of pertinent studies. The Planned Outage shall be advised at least 2 weeks in advance and confirmed in writing. The System Operator shall advise all Users and TSP of the return of any of the Equipment.

22.3.3. Voltage regulating Equipment

The System Operator shall coordinate all scheduled Outages of System Voltage regulating Equipment, such as AVRs on Generating Units, supplementary excitation control, synchronous condensers, shunt and series capacitors, reactors, etc. These Outages must be coordinated with the Outages of Transmission circuits in the vicinity.

22.3.4. Metering and control Equipment

The System Operator shall coordinate scheduled Outages of metering and control Equipment and associated communication channels.

22.3.5. Generator and TSP obligations

- (a) Generators shall specify with regard to each of their Generating Units or Power Park Modules, the start date, time and duration of each Outage. Statutory Outage plans for Generating Units or Power Park Modules for the year after the current year must reach the System Operator by the 1st of August of the current year pursuant to Subsection 22.3.1.
 - (i) The Generator shall ensure under its fuel supply and fuel transport agreements or under any fuel supply or transport code that it is informed of any outage planned in its fuel supply.
 - (ii) This information should be given sufficiently in advance to the SO such that it can be taken into account in this outage planning process.
- (b) TSP shall specify with regard to each of their items of Equipment the start date, time and duration of each Outage for the year after the current year. This must reach the System Operator by the 1st of August of the current year pursuant to Subsection 22.3.1.
- (c) TSP and each Generator shall act in accordance with Good Utility Practice in planning their Outages, so as to avoid a situation arising in which TSP or a Generator is obliged to schedule an Outage at short notice.
- (d) Generators (and TSP where relevant) shall specify the following, unless they reasonably substantiate that an Outage is inflexible:
 - (i) Alternative preferred windows of opportunity within the year for any Outage;
 - (ii) The minimum Outage duration which would be acceptable, if less than the scheduled Outage duration;
 - (iii) Situations where the paralleling of Outages of two or more of its Generating Units may be required, desirable, undesirable or not possible;
 - (iv) A priority order associated with the various Outages scheduled by the Generator; and
 - (v) Any Outages where it is particularly desirable that they should take place within the year scheduled.
- (e) Any Outage where its timing is dependent on Generating Unit or Power Park Module operating hours, equivalent operating hours or starts.

22.3.6. Distribution Network Operator and Directly Connected Customer Obligations

Each Distribution Network Operator shall act in accordance with Good Utility Practice in planning their circuit Outages. Each Distribution Company (and Directly Connected Customers where relevant) shall furnish by 1st of August of each year the following information:

- (a) Load in MW not to be available from any Connection Point.

-
- (b) Identification of Equipment and /or Apparatus at the Connection Point where there will be an Outage.
 - (c) Period during which a circuit at or near a Connection Point will be unavailable with Start-date and Start-time and End-date and End-time.

22.3.7. Outage scheduling programme

The System Operator shall present the coordinated Outage plans as well as the results of the Reliability studies in report format to the Commission for approval.

22.4. CHANGES TO THE COMMITTED OUTAGE SCHEDULING PROGRAMME

22.4.1. System Operator change request

The System Operator can, providing the relevant reasons, request a Generator to change the timing or duration of any Outage of one of the Generator's Generating Units or Power Park Modules in the Outage scheduling programme.

22.4.2. The System Operator can, providing the relevant reasons, request TSP to change the timing or duration of any Outage.

22.4.3. Generator or TSP response

A Generator may respond either by declining the request, or by agreeing to the request. Generators shall make every reasonable effort to co-operate with reasonable changes requested by the System Operator.

TSP may respond either by declining the request, or by agreeing to the request. TSP shall make every reasonable effort to co-operate with reasonable changes requested by the System Operator.

22.4.4. Agreement to conditions

If a Generator or TSP responds by agreeing to the request subject to specific conditions, the System Operator may respond by either confirming agreement to those conditions or by declining agreement. Where the System Operator agrees to the conditions, then the Outage scheduling programme shall be amended accordingly. Where the System Operator declines to agree to the conditions, then the System Operator may negotiate with the Generator or TSP as to revised or alternative conditions, which would be acceptable.

22.4.5. Generator or TSP change request

A Generator or TSP may at any time request the System Operator for a change in the timing or duration of any Outage of one of the Generator's Generating Units or Power Park Modules or TSP Equipment in the Outage scheduling programme. The System Operator may accept or decline the request. The Outage scheduling programme shall be amended accordingly or the System Operator shall negotiate with the Generator or TSP conditions, which shall be acceptable to both parties.

22.4.6. Deviations from Outage scheduling programme

The System Operator shall compile an annual report to indicate how the Outage scheduling programme of the previous year was adhered to. Specific reasons shall be provided for each deviation to the original approved Outage scheduling programme.

The Commission shall review this report in order to ensure the improvement of the System Operator's performance over a number of years.

22.5. OTHER INFORMATION TO BE NOTIFIED

22.5.1. Ancillary Services

Generators shall inform the System Operator of any proposed maintenance, in addition to Outages, which shall, or is likely to, affect the capability of the Generating Unit or Power Park Modules to provide Ancillary Services.

22.5.2. Security of supply

The System Operator shall request alterations to maintenance, where security of supply or the secure operation of the Transmission System would be at risk. The System Operator shall make reasonable endeavours to give as much notice as possible for such requests for alterations. Where the System Operator makes such a request, the Generator or TSP shall use reasonable endeavours to comply with the request in arriving at the Generator's or TSP's final programme for such maintenance.

23. SECTION: RELIABILITY MEASURES

23.1. OBJECTIVE

23.1.1. The objective of this Section is to define the Reliability criteria and measures the System Operator and the TSP have to adhere to in operating, maintaining and developing the Transmission System.

23.2. GENERAL

23.2.1. In order to maintain reliable operation of the Transmission System, it is necessary that all SO, TSP and Users observe and subscribe to certain minimum planning criteria.

23.2.2. The criteria and principles provided in this document serve as a guideline to develop criteria and methodologies applicable to the TSP, System Operator, Users and related Interconnections.

23.2.3. Reliability measures

Traditionally the measurement of transmission Reliability is achieved through the deterministic N-1 Criteria. This criterion should be regarded as a minimum standard. Additional to this the System Operator should develop probabilistic criteria. The fundamental attributes for Reliability measures to be considered to evaluate risk of probable extreme events include:

- (a) The frequency of events (e.g. frequency of circuit overload – 0.72 events/year);
- (b) Duration of events (e.g. duration of circuit overload – 2.5 hours/year); and
- (c) Severity of events (how does event impact on Load curtailment)

From these attributes other indices to quantify network performance can be calculated. To enable the definition of applicable indices, which may apply to the TSP and System Operator, a number of concepts and definitions related to network, configuration and aspects influencing network performance are discussed in Appendix 3.

23.3. APPLICABLE RELIABILITY CRITERIA

23.3.1. The System Operator shall study and assess the overall Reliability (adequacy and security) of the Power System, both existing and as planned, to ensure that the Power System development conforms to the Transmission Planning Criteria.

23.3.2. The System Operator shall develop Applicable Reliability Criteria for the Transmission System for approval by the Commission.

23.4. RELIABILITY INDICATORS

23.4.1. The Applicable Reliability Criteria as stated in Appendix 3 shall itemise specific measurable Reliability indicators. These can be expanded based on the System Operator, TSP

and Users' needs. All of these indicators must be measurable and calculable for a defined recording period. The length of the period should be measured in years to facilitate comparison.

23.5. REPORTING

23.5.1. The System Operator shall prepare and publish an annual assessment report of the Reliability of the Transmission System for review by the Commission.

23.5.2. To carry out these tasks, sufficient data and input must be made available to evaluate and analyse the Applicable Reliability Criteria.

24. SECTION: SYSTEM TESTING ON THE NETWORK

24.1. OBJECTIVE

24.1.1. The objective of this Section is to establish the approach to central co-ordination and control of a System Test required by the System Operator, the TSP or a User, where such test shall or may:

- (a) Affect the secure operation of the Transmission System;
- (b) Have a significant effect on the operation of the Transmission System or a User's System;
- (c) Affect the economic operation of the Transmission System or a User's System;
or
- (d) Affect the quality or continuity of electricity supply to Users.

24.2. GENERAL

24.2.1. This Section deals with the responsibilities and procedures for arranging and carrying out System Tests that may have an effect on the Systems of the TSP and/or Users.

24.2.2. By their nature, System Tests may have an impact on either or both of:

- (a) The System Operator's responsibilities in respect of the Transmission System, including Dispatch of Generation; and
- (b) The operations of Users and the quality and continuity of supply of electricity to Users.

24.2.3. To minimise disruption to the operation of the Transmission System and to the Systems of other Users, it is necessary that tests that affect the operation of the Transmission System or Users' Systems be subject to central co-ordination and control.

24.2.4. These tests are not intended to deal with tests that may be called for routinely by TSP or SO in order to assess compliance of Users with their defined design, operating and connection characteristics.

24.3. TESTS REQUIRED BY TSP OR SYSTEM OPERATOR

24.3.1. System Operator's responsibility

The System Operator as operator of the Transmission System shall carry out System Tests in accordance with Good Utility Practice, in order to maintain and develop operational procedures, to train staff, and to acquire information in respect of Power System behaviour under abnormal System conditions. The System Operator shall endeavour to limit the frequency of occurrence, scope, extent of effects and type of System Tests to those required by Good Utility Practice.

24.3.2. Range of tests

System Tests required by the System Operator or the TSP from time to time shall include, but shall not be limited to the following:

- (a) Tests involving the controlled application of Frequency and/or Voltage variations aimed at gathering information on Power System behaviour;
- (b) Power System restoration tests (i.e. Black Start test at a Power Station);
- (c) Testing of standing procedures for System Emergency Conditions; and
- (d) Testing or monitoring of power quality under various Power System conditions and Dispatch configurations.

24.3.3. Notice to Users

Where the System Operator or TSP intends to carry out a System Test, and such test will or may have an operational effect on a User's System, the System Operator shall provide notice to the relevant User of the scheduled time and effect of the System Test as is reasonable in all the circumstances and shall keep the relevant User informed as to any changes to the scheduled time and nature of the System Test.

24.3.4. Request for additional time

A User, having been informed about a System Test may contact the System Operator to request additional time to consider the impact of the test on the User. The System Operator shall co-operate with the User to assess the risks. The test shall not proceed until all Users are satisfied unless, in the System Operator's view, a User is acting unreasonably.

24.4. TESTS REQUIRED BY USER(S)

24.4.1. Users' responsibility

Operation of Users' Plant in accordance with Good Utility Practice requires System Testing in order to maintain and develop operational procedures, develop and measure Plant performance, comply with statutory or other industry obligations and to train staff.

In accordance with Good Utility Practice each User shall endeavour to limit the Frequency of occurrence of System Tests and to limit the effects of such System Tests on the Transmission System.

24.4.2. Procedure for requesting System Tests

Users shall submit a request for a System Test in time. As part of the request, the Users, when requesting a System Test, shall supply sufficient detail to the System Operator to allow any operational consequences of the test to be adequately assessed. This shall include the following information:

- (a) The reason for the proposed test;
- (b) The preferred time or times for the test;
- (c) The milestones for individual stages of the System Test;

-
- (d) Whether there may be an adverse material impact on the User if the System Test is cancelled at short notice or delayed; and
 - (e) Where the User is a Generator, the Dispatch required by the Generator for completion of the test.

Additionally, the factors that influence the completion of the stages should be outlined to the System Operator, e.g., if the procedure to be followed for a certain stage depends on the outcome of a previous stage.

24.4.3. Generator Specific request

A request by a Generator for a System Test requiring a Generating Unit or Power Park Module to be Dispatched to a particular Active Power output or operating condition shall not be considered a re-declaration of Availability, Ancillary Service capability or operating characteristics.

24.5. EVALUATION OF PROPOSED SYSTEM TESTS

24.5.1. Impact assessment

The System Operator shall, on receipt of a System Test request from a User, assess the impact of the proposed test on the operation of the Power System. The System Operator may request additional information from the User in order to evaluate the impact of the test.

24.5.2. Objections and sensitivity

The System Operator shall evaluate the impact of the System Test with Users that might be significantly affected. Any reasonable objections from any such Users shall be considered. When discussing the System Test with any affected User, the System Operator shall not disclose what it reasonably believes to be commercially sensitive or otherwise potentially sensitive information to Users without the consent of the User requesting the test.

24.5.3. Generator Dispatch outside currently registered values

Where a System Test requested by a Generator in respect of one of its Generating Units or Power Park Modules requires a Dispatch that is outside the currently registered values of Availability, Ancillary Service capability or operating characteristics of the Generating Unit or Power Park Module, then the System Operator may so Dispatch the Generating Unit or Power Park Module for the period required for the System Test.

24.6. APPROVAL FOR SYSTEM TESTS

24.6.1. Approval criteria

The criteria for approving System Tests shall include:

- (a) The impact of the System Test on Transmission System operational security;
- (b) The impact of the System Test on Transmission System operational economics;
- (c) The impact of the System Test on other Users' Systems; and

(d) The effect of the System Test on continuity and quality of electricity supply.

24.6.2. Proposed Dispatch procedure and schedule

On approval by the System Operator of a System Test requested by a User, who is a Generator, the System Operator shall contact the Generator outlining the proposed Dispatch procedure and schedule.

On receipt of the proposed Dispatch procedure and schedule of the System Test, the test requestor shall notify the System Operator without undue delay, of the test requestor's acceptance or rejection of the proposed Dispatch procedure and schedule for the System Test.

24.6.3. Rejection of Dispatch procedure and schedule

On notification of rejection of the proposed Dispatch procedure and schedule for the System Test by the test requestor, the System Test shall not take place. The test requestor may enter into discussions with the System Operator as to an alternative schedule for the System Test, or may request a different System Test, or may request the System Test at an alternative time.

24.6.4. Acceptance of Dispatch procedure and schedule

On notification of acceptance of the proposed Dispatch procedure and schedule for the System Test by the test requestor, the System Operator shall inform other Users as to the scheduled time and nature of the test, if in the opinion of the System Operator those Users shall or may be significantly affected by the test, or otherwise as dictated by standing arrangements.

24.6.5. Concerns by affected Users

If Users that might be significantly affected are not satisfied with the proposed System Test, they shall promptly advise the System Operator of their concerns. If the System Operator considers these objections to be unreasonable the proposed System Test shall not be cancelled. If operationally affected Users are still not satisfied with the System Test being approved they may appeal the decision to the Commission. In this latter case the affected Users must promptly inform the System Operator that they intend to appeal and the System Test shall not be allowed to take place until the Commission has decided in favour of it.

24.7. SCHEDULING OF SYSTEM TESTS

24.7.1. Where the System Operator requires a System Test, either:

- (a) The Generator/User shall nominate half-hourly Active Power outputs and constraints and the System Operator shall then Dispatch consistent with the planned System Test, or
- (b) Where System Test costs and conditions have been agreed in advance between the Generator/User and the System Operator, the Generator shall nominate in accordance with the System Operator requirements for the System Test.

24.7.2. Test prioritisation

The System Operator shall use reasonable endeavours to promptly schedule System Tests where the test requestor has notified the System Operator that System Tests are required in accordance with licence conditions, statutory regulations or safety Codes or that a delay in the execution of the tests may have an adverse material impact on the User.

24.8. DISPATCHING OF SYSTEM TESTS

24.8.1. Dispatch Instructions

The System Operator shall issue Dispatch Instructions for System Tests in the manner for issuing normal Dispatch Instructions.

The System Operator shall use reasonable endeavours to ensure that scheduled System Tests are Dispatched in accordance with the agreed Dispatch procedures.

24.8.2. Revised test procedure

Where the System Operator assesses that the impact of a System Test on Transmission System security or on the continuity and Quality of Supply or operation of a User may or is likely to be significantly greater than originally estimated, the System Operator may contact the test requestor to discuss a revised test procedure or schedule.

24.8.3. Possibility of cancellation or postponement

Where the System Operator foresees a requirement or likely requirement to cancel, postpone or otherwise significantly alter an agreed Dispatch procedure and schedule, then the System Operator shall inform the test requestor as soon as reasonably possible.

24.8.4. Cancellation, interruption or postponement of test

The System Operator may where it considers it necessary, cancel, interrupt or postpone a System Test at any time, but shall, where possible, utilise the agreed procedures prior to taking such action where the cancellation, interruption or postponement is for other than technical reasons.

24.8.5. Cancellation by test requestor

If the test requestor wishes to cancel a System Test either before commencement of the test or during the test, the test requestor shall notify the System Operator. Nominations and Dispatch Instructions shall remain valid when System Tests are cancelled.

24.9. TEST REPORTING

24.9.1. Scheduled completion time

Upon conclusion of the scheduled time for a System Test, the test requestor shall notify the System Operator as to whether the test, or sections of the test, if divided into sections, has been completed.

24.9.2. Reporting

At the conclusion of the System Test, the test requestor shall be responsible for preparing a written report on the System Test which shall be available to the System Operator, operationally effected Users and the Commission on request within 30 days of the conclusion of the System Test.

The Report shall include a description of the Plant and/or Apparatus tested and a description of the System test carried out together with the results, conclusions and recommendations as they relate to the System Operator and operationally affected Users.

24.9.3. Report confidentiality

The Report shall not be submitted to any person who is not a representative of the System Operator or the test requestor unless the System Operator and the test requestor, having reasonably considered the confidentiality issues arising shall have unanimously approved such submission.

24.10. DISPUTES

Disputes shall be handled according to relevant industry rules and regulations as approved by NERC.

25. SECTION: SAFETY AND CO-ORDINATION

25.1. OBJECTIVE

25.1.1. The objective of this Section is to achieve Safety on the network when either:

- (a) work on TSP Equipment necessitates the provision of Safety Precautions on User Equipment; or
- (b) work on User Equipment necessitates the provision of Safety Precautions on TSP Equipment.

25.1.2. A flow chart in Appendix 4C illustrates the process utilised in this Section to achieve Safety on the network. In the case of a conflict between the flow chart and the provisions of this Section, this Section will prevail.

25.2. GENERAL

25.2.1. This Section specifies the standard operating procedures to be used by System Operator, TSP and Users of the network for the co-ordination, establishment and maintenance of necessary Safety Precautions when work is to be carried out on the Transmission Network or on a User's Apparatus and when there is a need for Safety Precautions on the high Voltage Equipment on the other's System for work to be carried out safely. The term "work" includes testing, other than Network Tests. This Section applies between System Operator, TSP and Users and does not impose a particular set of Safety Rules on SO, TSP and Users; the Safety Rules to be adopted and used by SO, TSP and Users shall be those chosen by them. This Safety procedure applies to:

- (a) TSP
- (b) System Operator
- (c) Generators
- (d) Distribution Network Operators
- (e) Directly Connected Customers

25.3. INTERPRETATION

25.3.1. In this Section 25 the following terms shall have the meaning:

- (a) "High Voltage Equipment" means high Voltage electrical circuits forming part of a System, on which Safety from the System may be required or on which Safety Precautions may be applied to allow work to be carried out on a circuit.
- (b) "Isolation" means the disconnection of Equipment from the remainder of the network in which the Equipment is situated by either of the following:
 - (i) an Isolating Device maintained in an isolating position. The isolating position must either be:

-
- b.i.1) maintained by immobilising the Locking and Isolating Device in the isolating position and affixing a Caution Notice to it. Where the Isolating Device is Locked with a Safety Key, the Safety Key must be secured in a Key Safe. The Key Safe must be retained in a safe custody; or
 - b.i.2) maintained and/or secured by such other method which must be in accordance with the Local Safety Instructions of SO or that of the User, as the case may be; or
 - (ii) an adequate physical separation which must be in accordance with, and maintained by, the method set out in the Local Safety Instructions of SO or that of the User as the case may be, and, if it is a part of that method, a Caution Notice must be placed at the point of separation.
 - (c) “Earthing” means a way of providing a low impedance connection between conductors and the earth by an Earthing Device which is either:
 - (i) immobilised and Locked in an earthing position. Where the Earthing Device is Locked with a Safety Key, the Safety Key must be secured in a Key Safe. The Key Safe must be retained in a safe custody; or
 - (ii) maintained and/or secured by such other method which must be in accordance with the Local Safety Instructions of the SO or that of the User, as the case may be.

25.4. PROCEDURE

25.4.1. Approval of Local Safety Instructions

- (a) In accordance with the timing requirements of its Grid Connection Agreement with the TSP, each User will supply to the SO a copy of its Local Safety Instructions relating to its side of the Connection Point at each Connection Site.
- (b) In accordance with the timing requirements of each User Agreement, the SO will supply to each User a copy of its Local Safety Instructions relating to the TSP side of the Connection Point at each Connection Site.
- (c) Prior to connection each party must have approved the other’s relevant Local Safety Instructions in relation to Isolation and Earthing.
- (d) Either party may require that the Isolation and/or Earthing provisions in the other party’s Local Safety Instructions affecting the Connection Site should be made more stringent in order that approval of the other party’s Local Safety Instructions can be given. Provided that these requirements are not unreasonable, the other party will make such changes as soon as reasonably practicable.

If approved, a party that wishes to change the provisions in its Local Safety Instructions relating to Isolation and/or Earthing after approval, must inform the other party. If the change is to make the provisions more stringent, then the other party merely has to note the

changes. If the change is to relax the provisions, then the other party need to assess and approve the new provisions and procedures referred to in Subsection 25.4.1(c).

25.4.2. Safety Coordinators

For each Connection Point, the SO and each User must at all times have person(s) “Safety Coordinator(s)” to be responsible for the coordination of Safety Precautions when work is to be carried out on the network or parts of it which necessitates the provision of Safety Precautions on High Voltage Equipment pursuant to this Section of the Grid Code. A Safety Coordinator may be responsible for the coordination of safety at more than one Connection Point on the network.

Each Safety Coordinator shall be authorised by the SO or a User, as the case may be, as competent to carry out the functions set out to achieve Safety from the Network at all times.

Only Authorised Persons of the SO and the User(s) will carry out Safety activities at all times.

Contact between Safety Coordinators at SO and User(s) will be made via normal operational channels, and accordingly separate telephone numbers for Safety Coordinators need to be registered and available at SO and Users at all times.

If work is to be carried out on the network which necessitates the provision of Safety Precautions, in accordance with the provisions of this Section, the Requesting Safety Coordinator who requires Safety Precautions to be provided shall contact the relevant Implementing Safety Coordinator to coordinate the establishment of Safety Precautions throughout the work.

25.5. RECORD OF NETWORK SAFETY PRECAUTIONS (RNSP)

25.5.1. The SO and Users will use the format of the RNSP forms set out in Appendix 4A, and 4B of this Code. The one set out in Appendix 4A and designated as “RNSP-R” shall be used by the SO when the SO is Requesting Safety Coordinator, and the one in Appendix 4B designated as “RNSP-I” used by the SO when the SO is Implementing Safety Coordinator. The same shall apply to the User mutatis mutandis. Proformas of RNSP-R and RNSP-I must be provided by the SO and Users for use at all times when Safety Precaution is required.

25.5.2. All references to RNSP-R and RNSP-I shall be taken as referring to the corresponding parts of the alternative forms or other tangible written records agreed between the SO and the User.

25.5.3. RNSP-R will have an identifying number written or printed on it, comprising a prefix which identifies the location at which it is issued, and a unique serial number consisting of four digits and suffix “R” for the SO and the User.

25.5.4. Each User shall apply to the SO for approval of its proposed prefix

25.5.5. The SO shall consider the proposed prefix to see if it is the same as a prefix used by the SO or another User and that it is not confusing. The SO shall respond in writing within ten days of its decision on the prefix to the User.

25.5.6. If the SO disapproves, it shall explain in its response why it has disapproved and will suggest an alternative prefix. In this situation, the User shall either notify the SO in writing of its acceptance of the suggested alternative prefix or it shall apply in writing to the SO with its revised prefix proposal and the above procedure shall apply.

25.6. SAFETY PRECAUTIONS ON HIGH VOLTAGE EQUIPMENT

25.6.1. Safety Precautions

For the purpose of coordination of safety relating to High Voltage Equipment, the term “Safety Precautions” means Isolation and /or Earthing.

25.6.2. Agreement of Safety Precautions

The Safety Coordinator requesting Safety Precautions on Equipment or parts of the Transmission Network will contact the relevant Implementing Safety Coordinator to agree the location of the Safety Precautions to be established. This agreement will be recorded in the respective Safety Logs.

It is the responsibility of the implementing Safety Coordinator to ensure that adequate Safety Precautions are established and maintained. This can be in terms of his own Equipment and/or Equipment of another party connected to his Equipment, to enable Safety from the Equipment to be achieved on the High Voltage Equipment, specified by the Requesting Safety Coordinator which is to be identified in RNSP.

When the Implementing Safety Coordinator is of the reasonable opinion that it is necessary for Safety Precautions on the System of the Requesting Safety Coordinator, other than on the High Voltage Equipment specified by the Requesting Safety Coordinator, which is to be identified in RNSP, he shall contact the Requesting Safety Coordinator and the details shall be recorded in the RNSP forms. It is the responsibility of the Requesting Safety Coordinator to establish and maintain such Safety Precautions.

In the event where the Requesting Safety Coordinator and the Implementing Safety Coordinator are unable to agree on the location of the Isolation and Earthing (if requested), both shall be at the closest available points on the infeeds to the High Voltage Equipment on which Safety from the network is to be achieved as indicated on the operating diagram.

25.6.3. Implementation of Isolation

Following the agreement of the Safety Precautions in accordance with 25.6.2 the Implementing Safety Coordinator shall then establish the agreed Isolation.

The Implementing Safety Coordinator shall confirm to the requesting Safety Coordinator that the agreed Isolation has been established, and identify the Requesting Safety Coordinator’s High Voltage Equipment up to the Connection Point, for which the Isolation has been provided. The confirmation shall specify:

-
- (a) For each location, the identity (by means of High Voltage Equipment name, nomenclature and numbering or position as applicable) of each point of Isolation, whether Isolation has been achieved by an isolating Device in the isolating position or by an adequate physical separation;
 - (b) Where an Isolating Device has been used whether the isolating position is either:
 - (i) Maintained by immobilising and Locking the Isolating Device in the isolating position and affixing a Caution Notice to it, or
 - (ii) Where the Isolating Device has been Locked with a Safety Key that the Safety Key has been secured in a Key Safe and the Key Safe will be retained in a safe custody;
 - (c) Where an adequate physical separation has been used that will be in accordance with, and maintained by the method set out in the Local Safety Instructions of SO or that of the User, as the case may be, and, if it is part of that method, that a Caution Notice be placed at the point of separation.
 - (d) The confirmation of Isolation shall be recorded in the respective Safety Logs.

25.6.4. Implementation of Earthing

The Requesting Safety Coordinator will confirm to the Implementing Safety Coordinator that the relevant Isolation of its Equipment in the Safety Precautions agreed in 25.6.2 has been performed, in order that the Implementing Safety Coordinator may proceed to the Earthing phase.

The Implementing Safety Coordinator shall confirm to the Requesting Safety Coordinator that the agreed Earthing has been established, and identify the Requesting Safety Coordinator's High Voltage Equipment for which Earthing has been provided. The confirmation shall specify:

- (a) For each location, the identity (by means of the High Voltage Equipment name, nomenclature and numbering or position, as is applicable) of each point of Earthing; and
- (b) In respect of the Earthing Device used, whether it is:
 - (i) Immobilised and Locked in the Earthing position. Where the Earthing Device has been Locked with a Safety Key, that the Safety Key has been secured in a Key Safe and the Key Safe will be retained in safe custody; or
 - (ii) Maintained and/or secured in position by such other method which is in accordance with the Local Safety Instruction of the SO or that User, as the case may be.

The confirmation of Earthing shall be recorded in the respective Safety Logs.

The Implementing Safety Coordinator shall ensure that the established Safety Precautions are maintained until requested to be removed by the relevant Requesting Safety Coordinator.

25.6.5. Procedure for Issuing RNSP

Where Safety Precautions on Equipment are being provided to enable work on the Requesting Safety Coordinator's Equipment, before any work commences they must be recorded by the RNSP being issued. The RNSP is applicable to High Voltage Equipment up to the Connection Point identified in the RNSP-R and RNSP-I forms.

Where Safety Precautions are being provided to enable work to be carried out on both sides of the Connection Point an RNSP will need to be issued for each side of the Connection Point with the SO and the respective User each enacting the role of Requesting Safety Coordinator. This will result in an RNSP-R and RNSP-I form being completed by each of the SO and the User, with each Safety Coordinator issuing on RNSP number.

Once the Safety Precautions have been established, the Implementing Safety Coordinator shall complete form RNSP-I recording the details specified in 25.6.2, 25.6.3 and 25.6.4.

The Requesting Safety Coordinator shall complete form RNSP-R, making a precise copy of the details received. On completion, the Requesting Safety Coordinator shall read the entries made back to the sender and check that an accurate copy has been made.

The Requesting Safety Coordinator shall then issue the number of the RNSP taken from the RNSP-R, to the Implementing Safety Coordinator who will ensure that the number, including the prefix and suffix, is accurately recorded in the designated space on the RNSP-I form.

The Requesting Safety Coordinator and the Implementing Safety Coordinator shall complete and sign appropriate parts of the RNSP-R and RNSP-I forms respectively and then enter the time and date. When signed no alteration to the RNSP is permitted; the RNSP may only be cancelled.

The Requesting Safety Coordinator is then free to authorise work (including a test that does not affect the Implementing Safety Coordinator's Equipment. Where testing is to be carried out which affects the Implementing Safety Coordinator's Equipment, the procedure set out in 25.6.7 shall be implemented.

25.6.6. RNSP Cancellation Procedure

When the Requesting Safety Coordinator decides that Safety Precautions are no longer required, he will contact the relevant Implementing Safety Coordinator to effect cancellation of the associated RNSP.

The Requesting Safety Coordinator will inform the relevant Implementing Safety Coordinator of the RNSP identifying number (including the prefix and suffix), and agree it is the RNSP to be cancelled.

The Requesting Safety Coordinator and the relevant Implementing Safety Coordinator shall then respectively complete RNSP-R and RNSP-I forms with their names and contact address and shall then exchange details. On exchange of details the respective RNSP is cancelled.

Neither Safety Coordinator shall instruct the removal of any Isolation forming part of the Safety Precautions as part of the returning of the High Voltage Equipment to service until it is committed to each by each other that every earth on each side of the Connection Point, within the points of isolation identified on the RNSP has been removed or disconnected by the provision of additional Points of Isolation.

Subject to provisions in this Subsection the Implementing Safety Coordinator is then free to arrange the removal of the Safety Precautions, the procedure to achieve that being entirely an internal matter for the party the Implementing Safety Coordinator is representing. Nothing in this Code prevents the SO and Users agreeing to a simultaneous cancellation and issue a new RNSP, if both agree.

25.6.7. Testing Affecting another Safety Coordinator's Equipment

The carrying out of a test may affect Safety Precautions on RNSPs or work being carried out which does not require an RNSP. Testing can, for example include the application of an independent test voltage. Accordingly, where the Requesting Safety Coordinator wishes to authorise the carrying out of such a test to which the procedures in this Section of the Grid Code apply he may not do so and the test will not take place unless the steps in (a) to (c) below have been followed and confirmation of completion has been recorded in the respective Safety Logs:

- (a) Confirmation must be obtained from the Implementing Safety Coordinator that:
 - (i) no person is working on, or testing, or has been authorised to work on, or test, any part of its Equipment or another Equipment (other than the Equipment of the Requesting Safety Coordinator) within the points of Isolation identified on the RNSP form relating to the test which is proposed to be undertaken, and
 - (ii) no person will be so authorised until the proposed test has been completed (or cancelled) and the Requesting Safety Coordinator has notified the Implementing Safety Coordinator of its completion (or cancellation);
- (b) Any other current RNSP which relates to the parts of the Equipment in which the testing is to take place must have been cancelled in accordance with procedures set out in 25.6.6
- (c) The Implementing Safety Coordinator must agree with the Requesting Safety Coordinator to permit the testing on that part of the Equipment between the points of Isolation identified in the RNSP associated with the test and the points of Isolation on the Requesting Safety Coordinator's Equipment.
- (d) The Requesting Safety Coordinator will inform the Implementing Safety Coordinator as soon as the test has been completed or cancelled and the confirmation shall be recorded in the respective Safety Logs.
- (e) When the test gives rise to the removal of Earthing which it is not intended to re-apply, the relevant RNSP associated with the test shall be cancelled at the completion or cancellation of the test in accordance with the procedure set out

in either 25.6.5 or 25.6.6. Where the Earthing is re-applied following the completion or cancellation of the test, there is no requirement to cancel the relevant RNSP associated with the test pursuant to this Subsection.

25.6.8. Emergency Situations

There may be circumstances where Safety Precautions need to be established in relation to an unintended electrical connection or situations where there is an unintended risk of electrical connection between the Transmission Network and a User's Equipment, for example resulting from an incident where one line becomes attached or unacceptably close to another.

In those circumstances, if both the SO and the respective User agree, the relevant provisions of 25.6.5 will apply as if the electrical connections or potential connections were, solely for the purposes of this Section, a Connection Point.

The relevant Safety Coordinator shall be that for the electrically closest existing Connection Point to that User's Equipment or such other local Connection Point as may be agreed between the SO and the User, with discussions taking place between the relevant local Safety Coordinators. The Connection Point to be used shall be known in this Subsection as the "Relevant Connection Point".

- (a) The Local Safety Instructions shall be those which apply to the Relevant Connection Point.
- (b) The prefix for the RNSP will be that which applies for the Relevant Connection Point.

25.6.9. Loss of Integrity of Safety Precautions

In any instance when any Safety Precautions may be ineffective for any reason the relevant Safety Coordinator shall inform the other Safety Coordinator(s) without delay of that being the case and of the reasons why.

25.6.10. Safety Log

The SO and Users shall maintain Safety Logs which shall be a chronological record of all messages relating to Safety Coordination under this Code sent and received by the Safety Coordinator(s). The Safety Logs must be retained for a period of not less than one year.

26. SIGNIFICANT INCIDENT AND ACCIDENT REPORTING

26.1.1. Significant Incident

Every case where either, or a combination of the following happens:

- malfunctioning of Equipment, Apparatus connected to the Transmission Network;
- a person receives an electric shock, whether mild or serious or suffers an injury or burn, directly or indirectly due to electrical causes;

shall be treated as a Significant Incident. The System Operator personnel in charge of the concerned Equipment, Apparatus or area shall report the incident immediately to the highest responsible officer of the System Operator in charge within 12 hours. A

designated officer from the System Operator should reach the spot within 24 hours and assess the situation and probable cause of the accident, losses to consumers, and damage to Equipment, Apparatus of the TSP and or the User(s).

26.1.2. Whenever an accident occurs resulting in or likely to have resulted in loss of life or injury to human beings the above report should be followed by a detailed report within 48 hours. The System Operator shall take all other statutorily required actions, such as reporting to the police etc.

26.1.3. The System Operator shall send a preliminary report to the Nigerian Electricity Regulatory Commission of all Significant Incidents in the Power System which results in interruption to service, substantial damage to Equipment, loss of life, injury to human beings within 36 hours of its occurrence followed by a detailed report within two weeks.

26.1.4. For every Significant Incident relating to 26.1.2, NERC shall order an enquiry of the event. It should be completed with the least possible delay, in any case, not exceeding twenty days to guard against the possibility of destruction or disappearance of material evidence being presented, to escape responsibility. It should be a searching probe that may or not involve members of the security forces to uncover the root causes of the accident, which sometimes are quite difficult to ascertain. The enquiry should not only fix responsibility for the accident, but it is more important, to spell out steps to be taken to prevent such accidents in future.

26.1.5. The System Operator and the affected person or their agent shall establish a format and procedure for exchange of information for any Significant Incident event.

26.1.6. Users or their agent shall furnish information to the System Operator regarding any major incident occurring on their Systems promptly.

1. APPENDIX 1: DEFINITIONS

ELECTRICAL TERMS USED IN THE APPENDICES TAKE THEIR STANDARD INTERNATIONAL MEANINGS.

1.1. TABLE A 1

“Abnormal Operation”	has the meaning assigned in Subsection 20.2.1;
“AC”	means alternating current;
“ACC”	means area Control Centre;
“Act”	means the Electric Power Sector Reform Act, 2005, as amended;
“Active Power”	means the product of voltage and the in-phase component of alternating current measured in units of Watts and standard multiples thereof: 1000 Watts = 1 kW 1000 kW = 1 MW 1000 MW = 1 GW 1000 GW = 1 TW;
“Activation Time”	means the time delay between the activation of Reserve (either manually by the System Operator’s instruction, automatically by a central controller or by a Frequency condition) and the full, sustained availability of the declared Reserve power (in the case of full activation);
“Active Power Output”	means the sent out Active Power from a Generating Unit or Power Park Module or Power Station as appropriate;
“Agreements”	has the meaning assigned to that term in the Market Rules;
“Ancillary Service”	means a service, other than the primary production of electricity, which is used to operate a stable and secure Power System including but not limited to: Reactive Power, Operating Reserve, Frequency Control and Black Start Capability;
“Apparatus”	means all TSP Equipment, or User Equipment, as the case may be, in which electrical conductors are

		used, supported or which they form a part;
“Applicable Criteria”	Reliability	means the Reliability criteria that will ensure that the Power System development conforms to minimum planning criteria;
“ARC”		means automatic recloser;
“Area (ACE)”	Control Error	means the instantaneous difference between actual and scheduled interchange, taking into account the effects of Frequency bias (and time error or unilateral inadvertent error if automatic correction for either is part of the system's AGC);
“Authorised Person”		means a person authorised in writing by the SO or a User to carry out safety activities;
“Automatic Control (AGC)”	Generation	means the process whereby electronic Equipment automatically adjusts a Control Area’s Generation from a central location to maintain its Interchange Transaction Schedule plus Frequency bias;
Automatic Load Shedding		means Under-Frequency Load Shedding or Under-Voltage Load Shedding;
“Automatic Regulator (AVR)”	Voltage	means a continuously acting automatic closed loop control system acting on the excitation system so as to maintain a Generating Unit's terminal Voltage at a desired set point;
“Auxiliary”		means any item of Plant and/or Apparatus not directly a part of the boiler Plant or Generating Unit, but required for the boiler Plant's or Generating Unit's functional operation;
“Availability”		means a measure of the time a Generating Unit or Power Park Module, transmission line or other Facility as the case may be is capable of delivering Energy to the Transmission System at the delivery point or of providing Ancillary Services to the Transmission System and the term “Available” shall be construed accordingly;
“Back-up Control Centre”		means the alternative National Control Centre used in emergencies when the NCC is out of action;
“Black Start”		means the procedure necessary for a recovery from a Total Shutdown or Partial Shutdown;

“Black Start Capability”	means the capability of a Power Station to commence operation without an outside Energy supply so as to energise a defined position of a TCN controlled grid;
“Black Start Station”	means a Power Station, which has Black Start Capability;
“Bulk Power Energy Curtailment Index”	means the sum of Load (MW) lost multiplied by the frequency of such an event, divided by the actual amount of Load (MW) in the Power System. Given in equivalent number of Shutdowns per year;
“Business Day”	Has the meaning given in Subsection 2.8.1;
“Calculation Day”	has the meaning given in the Market Rules;
“Capability Chart”	means a chart, which shows the MW and MVAR capability limits at generator terminals within which a Generating Unit or Power Park Module will be expected to operate under steady state conditions;
“Caution Notice”	A notice conveying a warning against interference;
“CCGT”	Combine Cycle Gas Turbine. A generating unit comprising one or more gas turbine units (or other gas based units) and one or more steam units where in normal operation, the waste heat from the gas turbine is passed to the water/steam system of the associated steam unit(s) directly connected to the hot gas line which enable those units to contribute to improve efficiency of the combined cycle operation of the module;
“Code”	means this Code, (including the Appendices) as amended from time to time, and approved by the Commission, in accordance with the Market Rules;
“Commission” or “Regulator” or “NERC”	has the meaning assigned to that term in the Act or in the case of the definition NERC in Section 2.3.1;
“Conditions Precedent”	has the meaning assigned to that term in the Market Rules;
“Connection Facilities”	means the facilities at the Connection Point as defined in the relevant Grid Connection Agreement;
“Connection Point”	means the physical point where the User’s Plant is

		joined to the Transmission System;
“Connection Site”		means for each User’s Connection Point the associated substation;
“Control Action”		means any action required by the System Operator in controlling the Power System securely;
“Control Area”		means a Power System with Interconnections that is capable of maintaining continuous balance between the generation under its control, the consumption of electricity in the Control Area and the scheduled interchange with other Control Areas. The Nigerian Power System forms one Control Area;
“Control Centre”		means the centre responsible for monitoring and operation of the applicable network;
“CT”		means current transformer;
“Customer Damage Function (CDF)”		means the variation of a customer’s perception with regard to the worth of service Reliability as a function of interruption duration;
“Day-ahead Demand Forecast”		means the Demand Forecast for the following 24hrs starting at 00:00hrs;
“Day-ahead Nomination”		has the meaning assigned to that term in the Market Rules;
“Day-ahead Price”		has the meaning assigned to that term in the Market Rules;
“DC”		means direct current;
“De-energisation” or “De-energise(d)”		means the operation of any isolating device, breaker or switch or the removal of any fuse whereby no Electricity can flow to or from the relevant System through the User's Equipment;
“Demand”		means the rate at which electric Energy is delivered by the System or part of the System comprising of both Active and Reactive Power, unless otherwise stated;
“Demand Control”		means all or any of the methods of achieving a Demand reduction or an increase in Demand;

“Demand Forecast”	means an estimate of future Demand typically worked out by using mathematical forecasting techniques and historical Demand data, weather forecasts and other pertinent information;
“De-synchronise”	means the process of taking a Generating Unit or Power Park Module off a Power System to which it has been Synchronised, by opening any circuit breaker, and like terms shall be construed accordingly;
“Directly Connected Customer”	means a customer that is directly connected to the Transmission System;
“Disconnection”	is the permanent physical disconnection of the User's Equipment or Apparatus at any given Connection Site which permits removal thereof from the Connection Site or removal of all the TSP's Assets there from (as the case may be);
“Dispatch”	means the process by which the System Operator directs the operation of the Facility to cause a specified amount of Energy or Ancillary Services to be provided to or taken off the Power System. Inclusive of curtailment of Demand and Interchange Transaction Schedules in real time, to relieve congestion, to maintain the Reliability of the Power System and to comply with Applicable Reliability Criteria, as more particularly described in the Grid Code;
“Dispatch Day”	has the meaning assigned to that term in the Market Rules;
“Dispatch Instruction”	means the physical operating instruction issued by the System Operator to a User for its Dispatch in accordance with the Grid Code;
“Dispatch Period”	means any hour interval during a Dispatch Day, the first of which shall commence at 00:00 hours of the Dispatch Day and the last of which shall end at 24:00 hours of that Dispatch Day;
“Dispatch Schedule”	means the schedule developed by the System Operator in accordance with the Grid Code for a Dispatch Period not later than two hours prior to the commencement of the relevant Dispatch Period;

“Distribution”	means conveying Energy at Voltages of less than 132kV;
“Distribution Network” or “Distribution System”	means all electric lines used for Distribution of Energy to final consumers and includes any structures and Equipment used for that purpose which is connected to the Transmission System;
“Distribution Network Operator” or “Distribution System Operator”	means the Distributor who owns, operates and maintains a Distribution Network;
“Distributor”	means a User who is licensed to distribute electricity under Part IV section 67 of the Act;
“Eligible Customer”	has the meaning assigned to that term in the Act;
“Earthing”	has the meaning given in Section 25;
“Earthing Device”	means a device providing a low impedance connection between conductors and the earth;
“Embedded Generating Unit”	means a Generating Unit connected to a Distribution System or to a Directly Connected Customer System;
“Embedded Power Park Module”	means a Power Park Module connected to a Distribution System or to a Directly Connected Customer System;
“Emergency Generation”	means the short-term generation of the Plant above its rated capacity;
“Emergency Reserve”	means reserve which is only used in emergencies which is typically made up from contracted interruptible Load, gas turbines (e.g. open cycle) and other Emergency Generation;
“Energy”	has the meaning assigned to that term in the Market Rules;
“Equipment”	Any machinery, Apparatus (stand alone or connected) that forms part of a System or sub System involved in production, transportation and consumption of electricity;
“ESI”	means Electricity Supply Industry;

“Event”		Has the meaning assigned in Subsection 20.2.1;
“Expected Energy”	Unreserved	means the sum of Energy lost due to System unreliability and is measured in MWh per annum;
“Expert”		has the meaning given in Subsection 3.3.3;
“Facility”		has the meaning assigned to that term in the Market Rules;
“Fault Level”		means prospective current that would flow into a short circuit at a stated point on the System and which may be expressed in kA or, if referred to a particular Voltage, in MVA;
“Fault Ride Through”		means the ability of a Power Park Module to remain connected during system Voltage disturbances. These disturbances may be temporary low or high Voltages as observed at the Connection Point, and which are outside of the normal operating range;
“Flicker”		means impression of unsteadiness of visual sensation induced by a light stimulus whose luminance or spectral Distribution fluctuates with time;
“Force Majeure”		has the meaning assigned to that term in the Market Rules;
“Forced Outage”		means an unanticipated or automatic removal from service of, the temporary de-rating of, restriction of use of, or reduction in performance of Equipment;
“Frequency”		means the number of alternating current cycles per second (expressed in Hertz) at which a System is running;
“Frequency Control”		means the retention of the Frequency on the Power System within acceptable limits;
“Gas Turbine Unit”		means a Generating Unit driven by a gas turbine (e.g. an aero-engine);
“Generate Generation”	and	has the meaning assigned to that term in the Market Rules;
“Generating Unit”		Any Apparatus or Equipment which produces electricity, including, for the avoidance of doubt, a CCGT unit;

“Generator”		A person or corporate entity who produces electricity under licence or exemption under the Electric Power Sector Reform Act, 2005 or its successor Act;
“Good Utility Practice”		means any of the international practices, methods and acts engaged in or approved by a significant portion of the electric utility industry during the relevant time period and under similar conditions as exist in Nigeria, or any of the practices, methods and acts in which, in the exercise of reasonable judgement in light of the faith known at the time the decision was made, could have been expected to accomplish the desired result at a reasonable cost consistent with good business practice, Reliability, safety and expedition; however for the sake of clarity, it is not intended that the item Good Utility Practice be limited to optimum practice, method or act to the exclusion of all others, but rather than intention is to refer to acceptable practices, methods or acts internationally;
“Governor System”	Control	means a self-correcting system that will adjust Active Power output of a Generating Unit, in response to a change in System Frequency, such that the Generating Unit assists in the recovery to Target Frequency;
“Governor Droop”		means the percentage steady state drop in the Frequency that would cause the Generating Unit under free governor action to change its output from zero to stated capacity;
“Grid Code”		means this Code as defined in the Act, as amended from time to time, and approved by the Commission, in accordance with the Market Rules;
“Grid Agreement”	Connection	Means the compulsory agreement, approved by the Commission, between the TSP and a User (in particular a DCC as an eligible customer) for Connection of the specific Facilities of the User to the Power System and the interface between User, TSP and SO. As the context dictates this may be construed to include the Transmission Use of System Agreement which covers the charges the TSP applies to the User for using its Transmission System;

“Harmonics”		means sinusoidal currents with a Frequency equal to an integer multiple of the fundamental Frequency of the connection Voltage;
“High Voltage”		means a Voltage, used for the supply of electricity, whose lower limit of nominal root-mean-square value is greater than or equal to 132kV;
“High Voltage Equipment”	Voltage	Has the meaning given in Section 25 and applies in Section 25 and Appendix 4;
“Hot Line”		means a direct voice line between two locations which are 100 % of the time available and not subject to any switching via the communication switch network;
“HP”		means High Pressure;
“HV”		means High Voltage;
“Hz”		means Hertz (Frequency);
“IEC”		means International Electrotechnical Commission;
“Imbalance Energy”		has the meaning assigned to that term in the Market Rules;
“Interconnected Network”		means a network with more than one Control Area Synchronously Connected which in terms of this Code means the West African Power Pool or part of it. For the avoidance of doubt the practice of feeding parts of Niger and Benin disconnected from the rest of their countries’ Systems does not make an Interconnected Network;
“Interconnection Agreement”		has the meaning assigned to that term in the Market Rules;
“Interconnector Capacity Entitlement”	Capacity	has the meaning assigned to that term in the Market Rules;
“Interconnector Energy Trade Nomination”	Energy	has the meaning assigned to that term in the Market Rules;
“Interrupted Energy Assessment Rate (IEAR)”	Energy	means the factor that relates the customer losses caused by electric power interruptions to the worth of electric service Reliability;
“Interruptible Load”		means a portion or a combination of a Distributor

		Load or a Directly Connected Customer Load that can be interrupted or reduced by remote control or on instruction from the System Operator pursuant to a contract between such Distributor or Directly Connected Customer and the TCN;
“IP”		means Intermediate Pressure;
“Isolating Device”		means a device which ensures the disconnection of Equipment from the remainder of the network;
“Isolation”		Has the meaning defined in Section 25;
“Key Safe”		means a safe in which keys used to ensure Isolation and Earthing are kept;
“kV”		means kilovolt;
“kVA”		means kilovolt-ampere;
“Largest Credible Trip”		has the meaning given in Subsection 15.4.2;
“Load”		means the amount of electric power delivered or required at any specified point or points on a System;
“Load Factor”		means the ratio of the actual electrical Energy produced by a Generating Unit or Power Park Module to the possible maximum electrical Energy that could be produced by that Generating Unit or Power Park Module in any defined period;
“Load Shedding Severity Index”		means the annual expected duration of Load curtailment and is measured in minutes;
“Local Safety Instructions”		means the safety instructions of the SO or User as applicable;
“Locked”		means a secured Isolating or Earthing Device;
“Locking and Isolating Device”		means an Isolating Device that is lockable;
“Low Voltage”		means a Voltage, used for the supply of electricity, whose upper limit of nominal root-mean-square value is 1kV;
“LP”		means Low Pressure;

“LV”	means Low Voltage;
“Market Rules” or “Rules”	means the electricity market rules as defined in the Act, as amended from time to time, and approved by the Commission;
“Medium Term Stage”	has the meaning assigned to that term in the Market Rules;
“Medium Voltage”	means a Voltage, used for the supply of electricity, whose nominal root-means-square value lies between 1kV and 132kV;
“Meter”	means a device that measures and registers electrical parameters including active or reactive Energy or Power and voltage or current;
“Meter Data”	has the meaning assigned to that term in the Market Rules;
“Metering Installation”	means any Apparatus used to measure the Energy flowing through a specified point in the Power System, which provides remote access to Meter Data and which may provide remote monitoring of Equipment conditions, including Meters, instrument transformers, secondary circuitry, secondary devices, meter data services, related communication Facilities and related local Equipment;
“MVA”	means megavolt-ampere;
“MVA _r ”	means megavar (1,000,000 vars), the unit for Reactive Power;
“MVA _{rh} ”	means megavar hour;
“MW”	means megawatt (1,000,000 watts), the unit for Active Power;
“MWh”	means megawatt hour;
“National Control Centre (NCC)”	means the National Control Centre of the Nigerian Transmission System;
“Network Constrained Capacity”	has the meaning assigned in 8.3.2;
“Nigerian Bulk Electricity	means the entity responsible for purchasing Energy

Trader (NBET)”		and Ancillary Services from Generators;
“Nigerian Electricity Supply Industry”		means the electricity industry of Nigeria including all traders, Users of the Transmission System and Participants in the electricity market;
“Node”		means the busbars at the end terminal of a branch of the Power System;
“Nomination”		has the meaning assigned to that term in the Market Rules;
“Normal Margin”	Regulating	means the minimum on-line capacity that can be increased or decreased to allow the System to respond to all reasonable Demand changes;
“N-1 Criteria”		means that a System is sufficiently reliable if it is able to operate acceptably under any unplanned outage of Equipment due to a single cause;
“Off-taker”		means a Distribution Network Operator or a Directly Connected Customer;
“Operating Agreement”		means an agreement between the System Operator and a User covering operational issues such as for example intertripping;
“Operating Reserve”		means the unused capacity above System Demand, which is required to cater for regulation, short-term Load and Power Park Module forecasting errors, and unplanned Plant Outages. It consists of Quick Reserve and Slow Reserve;
“Operating Policy”	Reserve	means the document prepared by the System Operator and approved by NERC which specifies the permissible mix of different types of reserve that will be used during the dispatch and real time operation;
“Operating Security”		means the ability of a Power System to withstand or limit the adverse effects of any credible contingency to the System including overloads beyond emergency ratings, excessive or inadequate Voltage, and loss of stability or abnormal Frequency deviations;
“Operating State”		means any or all of the states as defined in Subsection 18.2.2 of this Code;

“Operational Planning”	means all those actions as defined in Section 19 of this Code;
“Outage”	means the removal of Equipment from service, unavailability for connection of Equipment, restriction of use for any reason including, but not limited to, to permit the performance of inspections, tests or repairs on Equipment, and shall include a Planned Outage, an Unplanned Outage and a Forced Outage;
“Partial Shutdown”	means that there is a partial loss of the Power System, and that there has been substantial Generation and Load loss;
“Planned Outage”	unless otherwise agreed between all relevant Control Centres, Planned Outages shall mean Outages, which are scheduled as part of the Outage scheduling plan and confirmed two weeks in advance.;
“Plant”	means fixed and movable Equipment used in the generation and/or transmission and/or distribution of electricity other than Apparatus. For the avoidance of doubt, Equipment may be considered to be Plant even though it contains LV conductors that provide electrical power for that Plant item;
“PLC”	means power line carrier;
“Power Factor Control”	A method of controlling the Reactive Power exchange from a Generator’s site at the Connection Point, to a specified power factor, leading or lagging, depending on the Active Power generated by that Generator’s site as measured at the Connection Point.;
“Power Park Module”	A collection of Power Park Units joined together by a System and connected to the Transmission System or Distribution System via a single Connection Point;
“Power Park Unit”	An individual non-synchronous generating unit contained within a Power Park Module. For the avoidance of doubt, this may include, but is not limited to, a wind turbine generator or PV converter module , or non-synchronous storage device;

“Power Station”	has the meaning assigned to that term in the Market Rules;
“Power System”	means a network of Power Stations, Load Facilities, Transmission Systems and Distribution Systems, including the associated Equipment electrically or mechanically connected;
“Power System Stabiliser (PSS)”	means a device that injects a supplementary signal into the AVR (Automatic Voltage Regulator) in order to improve Power System damping;
“Pre-dispatch Day”	has the meaning assigned to that term in the Market Rules;
“Primary Reserve”	means reserve that is provided automatically and immediately to correct drops in frequency
“Procedure”	means a document governing the actions of the System Operator, TSP and Users in an orderly manner which is subservient to this Code: <ul style="list-style-type: none"> • it can be a “System Operation Procedure” where the System Operator has responsibility for it; or • a transmission Procedure where the TSP has responsibility for it;
“Protection Scheme”	means the provisions for detecting abnormal conditions in the Power System and initiating fault clearance or actuating signals or indications;
“Q(P) Control”	means a method of controlling the Reactive Power exchange from a Generator’s site at the Connection Point, to a specified characteristic whereby the site maintains unity power factor (0 MVar exchange) from zero Active Power to a specified Active Power value. Above this Active Power value the site should control Reactive Power linearly up to a Reactive Power (MVar) value specified at full Active Power output, as measured at the Connection Point;
“Quality of Supply”	means the quality of electrical power as measured at Connection Points. Typical parameters of power quality are the harmonic content; flicker and Voltage fluctuations;
“Quantity Nomination”	has the meaning assigned to that term in the Market

	Rules;
“Quick Reserve”	means the reserve used for balancing the System within one Dispatch Period. It is comprised of Primary, Secondary, Tertiary and Emergency Reserve. Primary Reserve and Secondary Reserve is activated automatically for controlling the Frequency of the System. Tertiary Reserve and Emergency Reserve are manually activated by the System Operator and are used for substituting Primary and Secondary Reserve and for balancing the System in the time frame of several minutes (Formerly known as Spinning Reserve);
“Reactive Power”	means the product of voltage and current and the sine of the phase angle between them measured in units of volt-amperes reactive and standard multiples thereof i.e. 1000 VAr = 1kVAr 1000kVAr = 1MVar;
“Reactive Power Control”	means a method of controlling the Reactive Power exchange from a Generator’s site at the Connection Point, to a specified Reactive Power value (e.g. MVar value);
“Record Of Network Safety Precautions (RNSP)”	has the meaning given in Subsection 25.5 and can either be a “Record Of Network Safety Precautions - Requesting (RNSP-R)” or a “Record Of Network Safety Precautions - Implementing (RNSP-I)”;
“Registered Capacity”	means for a Generating Unit other than a CCGT Module, the normal full load capacity (MW) of the Generating Unit as declared by the Generator, less the MW consumed by the Generating Unit’s unit transformer when producing at full load. For a CCGT Module, the normal full load capacity (MW) of a CCGT Module as declared by the Generator, being the Active Power declared deliverable by the CCGT Module at the Grid or Interconnected Entry Point to a network. For a Power Park Module the maximum potential full load capacity (MW) declared by the Generator which is available at the Connection Point;
“Registered Information”	has the meaning assigned to that term in the Market Rules;

“Regulatory Long Term Transmission Plan”		means the plan developed by the System Operator and approved by NERC which specifies the additions or refurbishments to be developed in the Transmission System in a predefined period in the future;
“Relevant Connection Point”		has the meaning ascribed in Subsection 25.6.8;
“Reliability”		means in respect of the Power System, the ability of the Power System to operate and deliver Energy within Applicable Reliability Criteria in an adequate and secure manner;
“Reliability Must-run Agreement”		has the meaning assigned to that term in the Market Rules;
“Reliability Must-run Unit”		has the meaning assigned to that term in the Market Rules;
“Remote Terminal Unit” or “RTU”		means the computer unit in the substation that communicates readings and status changes of Equipment to the main SCADA computer at NCC;
“Renewable Energy”		means a type of electricity generated from an energy resource that is replaced rapidly by a natural process such as from the sun (e.g. solar PV, biomass), wind (e.g. wind power, wave power), earth’s core (e.g. geothermal), or the moon (e.g. tidal);
“Responsible Manager”		means the person representing the User and shall be responsible for dealing with issues relating to this Code;
“Rotational Load Shedding”		means the manual disconnection of customer or User circuits to reduce Load on the System over a period of time. This will be done by some rota system agreed with the Commission and/or the Ministry of Power;
“Safety”		means the operation of the Power System in such a manner as not to cause risk of injury or death to any person or risk of damage to any Equipment;
“Safety Coordinators		Has the meaning given in Subsection 25.4.2 they can either be a “Requesting Safety Coordinator” or an “Implementing Safety Coordinator”;
“Safety Key”		means a key used for locking an Earthing or

	Isolating Device;
“Safety Log”	means the log book in the relevant Control Room where Safety Precautions, instructions and incidents are logged;
“Safety Precautions”	Has the meaning given in Subsection 25.6.1;
“Secondary Reserve”	means the capability of a Generating Unit to have its generated outputs adjusted frequently (e.g. by AGC) so that any Power System Frequency variations can be corrected;
“Section”	means a provision in the body of this Code if the reference is in the body or to a provision in an Appendix if the reference is in that Appendix;
“Service Provider”	means the System Operator or the Transmission Service Provider or if the context requires the Market Operator or NBET;
“Single Line Diagram”	means a drawing of electrical circuits where three phase circuits are represented by a single line rather than three lines;
“Slow Reserve”	means available capacity ready for Synchronisation to the Transmission System within an agreed contracted timescale (e.g. 4 hours). The purpose of Slow Reserve is to replace any Generating Units on Unplanned Outages or to meet forecast Demand;
“Station Capacity”	means the capacity of a Power Station being the sum of the Generating Unit Registered Capacities minus the Station Transformer Load;
“Station Transformer” or “Station Service Transformer”	means the transformer at a Power Station or a Transmission substation that directly supplies the station Load;
“Subsection”	means a specific provision in this Code;
“Subtransmission”	means at Voltages just below those of the Transmission Network i.e. 11kV, 33kV or 66kV;
“Subtransmission System”	means a Distributor or Directly Connected Customer System that is at Subtransmission Voltages which may contain Embedded Generating Units or Power Park Modules or connect in parallel between Connection Points;

“Supervisory Control and Data Acquisition (SCADA)”	means a system of remote control and telemetry used to monitor and control the Power System;
“Switched Voice Circuit”	means a voice line between different Users which are established via the communication network through a process of exchanging various switching actions before the voice connection is established between the Users;
“Synchronise”	means the process of connecting two Energy supplies together in parallel or the selection of the appropriate time for switching a synchronous Generating Unit or Power Park Module onto energised busbars or into parallel with another normally running synchronous Generating Unit and like terms shall be construed accordingly;
“Synchronous Compensation Mode”	means the operation of a Generating Unit or Power Park Module by importing Active Power from the System so as to provide Voltage Control and Reactive Power for the System;
“System”	User(s) or TSP Apparatus or Equipment which can be ‘stand-alone’ or connected to other Equipment or Apparatus, employed in activities involving production, supply and consumption of electricity;
“System Disturbance”	means any disturbance that results in localised or widespread loss of Load or resulting in one or more of the following phenomena: System instability, cascading Outages, formation of islands, or undesirable Voltage or Frequency;
“System Emergency Condition”	means the condition that the Power System is in when under stress. This is normally related to a shortage of generation and the Power System Frequency dropping to below predefined emergency limits;
“System Marginal Price”	has the meaning assigned to that term in the Market Rules;
“System Minutes”	means the sum of Energy (MW Minutes) lost, divided by the peak Demand (MW) in the Power System;
“System Operator” or	means the holder of a System Operation License;

“SO”	
“System Stability”	means the dynamic behaviour of the Power System following a disturbance, being its ability to automatically return to a normal state;
“System Tests”	means those tests which involve simulating conditions and recording them or the controlled application of irregular, unusual or extreme conditions on the Power System or any part of it and recording them, but not including routine testing, commissioning or re-commissioning tests;
“TCN”	means the Transmission Company of Nigeria;
“Total Shutdown”	means the complete failure of the Power System to function;
“Tertiary Reserve”	Quick Reserve that can be manually instructed by the SO to replace Secondary Reserve, and to balance Load and Power Park Module forecast errors;
“Transitional Stage”	has the meaning assigned to that term in the Market Rules;
“Transmission”	means conveying Energy at Voltages of greater than or equal to 132kV;
“Transmission Constraint”	means a limit imposed on power transfer across any part of the Transmission System due to thermal overload, Voltage or stability considerations;
“Transmission Planning Criteria”	means a set of criteria to be used to plan and develop the Transmission System;
“Transmission Service Provider (TSP)”	means the division of TCN that owns and maintains the Transmission Network;
“Transmission System” or “Transmission Network”	means the System or network of electric lines comprising wholly or mainly high Voltage lines and electric Plant and which is used for Transmission of Energy from a Power Station to a substation, from one Power Station to another, from one substation to another or to or from any Interconnector or to final consumers, and includes any structures and Equipment for that purpose;
“Under-Frequency”	means Frequencies below the nominal Frequency

	of 50Hz;
“Under-Frequency Load Shedding”	means the automatic tripping of customer Load by means of one or more relays set to trip at specific Under-Frequencies which during a sudden mismatch between Generation and customer Load attempts to prevent System shutdown;
“Unintentional Islanding”	means the unintentional energisation of a part of a system. For example, it could be the unintentional separation of part of a system which was not conceived to operate in an island mode. Alternatively, if a feeder is disconnected for maintenance work and back-energized by local generation, the feeder forms an unintentional island;
“Unplanned Outage or Emergency Outage”	means unless otherwise agreed between all relevant Control Centres, Unplanned Outages shall mean Outages which are not scheduled with the necessary advance notice;
“Unreliability”	has the meaning assigned in Appendix 3.3 and applies to Appendix 3;
“Usage Charge”	has the meaning assigned to that term in the Market Rules;
“Users”	means a person or party using Transmission System as agreed and permitted by the TSP and NBET;
“Voltage”	means a measure of electrical pressure or potential as it applies to a System. One volt being the potential difference between two points where there is a current flow of one amp through a resistance of one ohm;
“Voltage Control”	means the retention of the Voltage on the System within acceptable limits;
“Voltage Dip”	means a sudden reduction of the Voltage to a value between 90% and 100% of the nominal Voltage followed by a Voltage recovery after a short period of time;
“Voltage Droop”	means the relationship between Voltage and Reactive Power, specified in percent, for use in the

	Voltage Droop Control. The value represents the change in Voltage which will cause a Generator's site to move from 0 MVAR exchange to full Reactive Power exchange at the Connection Point;
“Voltage Droop Control”	means a method of controlling the Reactive Power exchange from a Generator's site at the Connection Point, depending on the Voltage, Voltage Droop and Voltage Target settings;
“Voltage Fluctuations”	means a series of rapid Voltage changes, which may be regular or irregular;
“Voltage Reduction”	means the method to temporarily control Demand by reduction of the entire System Voltage;
“Voltage Support”	means injection or withdrawal of Reactive Power by means of changing the excitation of Generating Units, or Power Park Module Voltage Control or Reactive Power Control settings, or operation of reactive compensation devices to maintain Voltages across the Power System within a specified range;
“Voltage Unbalance”	means a condition in a three-phase network in which the root-mean-square value of the phase Voltages or the phase angles between consecutive phases is not equal;
“VT”	means voltage transformer; and
“West African Power Pool (WAPP)”	has the meaning defined in the relevant inter-governmental agreement between the participating countries in West Africa.

2. APPENDIX 2: CONDITIONS PRECEDENT

The Conditions Precedent for this Code are already in place.
Order No. NERC/GL022 empowers this Code.

3. APPENDIX 3: RELIABILITY CONCEPTS AND DEFINITIONS

3.1 Introduction

The Nigerian Power System consists of those Generation and Transmission facilities, which are controlled by the TCN System Operator and which function as part of an integrated and coordinated power supply network.

In order to maintain reliable operation of the Transmission System, it is necessary that all Systems observe and subscribe to certain minimum planning criteria. The criteria and principles provided in this Appendix serves as a guideline to develop criteria and methodologies applicable to the TCN and related interconnections and customers.

This Appendix 3 consists of this introduction and a conclusion together with three sections as follows:

Section 2 provides guidelines to transmission contingency criteria based on NERC standards,

Section 3 provides guidelines to the measuring of Reliability indices in order to produce annual performance figures, and

Section 4 provides guidelines with regard to the measurement of the value of network infrastructure.

This Appendix thus provides guidelines that can be used to direct the TCN planning and operational criteria in future. It does not provide the procedures and measures required to ensure that the criteria are followed. Neither does the Appendix direct responsibility to any of the TCN divisions. These issues will need to be developed and resolved before criteria of this nature can effectively be implemented.

3.2 Transmission Reliability Criteria

In general an interconnection philosophy is to minimize loss of Load by remaining interconnected. Interconnected System planning will include steady state and dynamic simulated testing to represent specific occurrences for each type of contingency specified below or listed in Table A2 of this Planning Standard. The contingency tests will be performed for reasonable variations of Load level, Dispatch Schedules, planned Transmission line maintenance outages, and anticipated power transfers. At a minimum, this should include projected Loads for the upcoming dry and wet seasons and a ten-year planning horizon. The Transmission providers involved should plan to resolve any unacceptable test results through the provision of Transmission Facilities, the alteration of System Operation Procedures, or other means as appropriate.

While the requirements listed in Table A2 address most planning concerns, tests will also be conducted to ensure that the planned System conforms to the following additional requirements:

The contingency loss of a double-circuit Transmission line in length (either without a fault or subsequent to a normally-cleared non-three-phase fault) with all other facilities normal should not cause:

- a. cascading or uncontrolled outages,

-
- b. instability of Generating Units or Power Park Modules at multiple Plant locations, or
 - c. interruption of service to firm Demand or Generation other than that isolated by the double-circuit loss,

following the execution of all automatic operating actions such as relaying and special protection systems.

Furthermore, the loss should result in no damage to or failure of Equipment and, following the execution of specific non-automatic predefined operator-directed actions such as re-dispatch, curtailment of interruptible Load, or curtailment of unplanned transfers, should not result in applicable Voltage or thermal ratings being exceeded.

With any single Generating Unit unavailable, and with any other generation pre-emptively re-dispatched, the contingency loss of a single transmission element (either without a fault or subsequent to a normally-cleared non-three-phase fault) with all other facilities normal should not cause:

- a. cascading or uncontrolled outages,
- b. instability of Generating Units or Power Park Modules at multiple Plant locations, or
- c. interruption of service to firm Demand or generation other than that isolated by the transmission element,

following the execution of all automatic operating actions such as relaying and special protection systems.

Furthermore, the loss should result in no damage to or failure of Equipment and, following the execution of specific non-automatic predefined operator-directed actions such as re-dispatch, curtailment of interruptible Load, or curtailment of unplanned transfers, should not result in applicable Voltage or thermal ratings being exceeded.

3.2.1 Report and Testing

Annual preparation of adequacy indices of the TCN Power System will be required. This should be read in conjunction with the long-term planning reports for infrastructure additions with possible quantification of the worth of these network additions as outlined in Section 4. These working papers to report the results of System tests future planning reports will provide the basis for statements concerning the adequacy of the planned TCN System.

Table A2. Transmission Systems Standards — Normal and Contingency Conditions

Category	Contingencies		System Limits or Impacts				
	Initiating Event(s) and Contingency Component(s)	Components Out of Service	Thermal Limits	Voltage Limits	System Stable	Loss of Demand or Curtailed Firm Transfers	Cascading ^c Outages
A – No Contingencies	All Facilities in Service	None	Normal	Normal	Yes	No	No
B – Event resulting in the loss of a single component.	Single Line Ground (SLG) or 3-Phase (3Ø) Fault, with Normal Clearing:	Single	Applicable Rating ^a (A/R)	Applicable Rating ^a (A/R)	Yes	No ^b	No
	1. Generator	Single	A/R	A/R	Yes	No ^b	No
	2. Transmission Circuit	Single	A/R	A/R	Yes	No ^b	No
	3. Transformer	Single	A/R	A/R	Yes	No ^b	No
	Loss of a Component without a Fault.						

C – Event(s) resulting in the loss of two or more (multiple) components.	SLG Fault, with Normal Clearing: 1. Bus Section	Multiple	A/R	A/R	Yes	Planned ^d	No
	2. Breaker (failure or internal fault)	Multiple	A/R	A/R	Yes	Planned ^d	No
	SLG or 3Ø Fault, with Normal Clearing, Manual System Adjustments, followed by another SLG or 3Ø Fault, with Normal Clearing: 3. Category B (B1, B2, B3) contingency, manual system adjustments, followed by another Category B (B1, B2, B3) contingency	Multiple	A/R	A/R	Yes	Planned ^d	No
	Fault (non 3Ø), with Normal Clearing: 4. Double Circuit line	Multiple	A/R	A/R	Yes	Planned ^d	No
	SLG Fault, with Delayed Clearing: 5. Generator 7. Transformer 6. Transmission Circuit 8. Bus Section	Multiple Multiple	A/R A/R	A/R A/R	Yes Yes	Planned ^d Planned ^d	No No
D ^e – Extreme event	3Ø Fault, with Delayed Clearing (stuck breaker or protection system failure):	Evaluate for risks and consequences.					

<p>resulting in two or more (multiple) components removed or cascading out of service</p>	<p>1. Generator 3. Transformer 2. Transmission Circuit 4. Bus Section 3Ø Fault, with Normal Clearing: 5. Breaker (failure or internal fault) Other: 6. Loss of line with three or more circuits 7. All transmission lines on a common right-of way 8. Loss of a substation (one voltage level plus transformers) 9. Loss of a switching station (one voltage level plus transformers) 10. Loss of all generating units or Power Park Modules at a station 11. Loss of a large load or major load centre 12. Failure of a fully redundant special protection system (or remedial action scheme) to operate when required 13. Operation, partial operation, or mis-operation of a fully redundant special protection system (or remedial action scheme) for an event or condition for which it was not intended to operate 14. Impact of severe power swings or oscillations from disturbances in another Regional Council.</p>	<p><input type="checkbox"/> May involve substantial loss of customer demand and generation in a widespread area or areas.</p> <p><input type="checkbox"/> Portions or all of the interconnected systems may or may not achieve a new, stable operating point.</p> <p><input type="checkbox"/> Evaluation of these events may require joint studies with neighbouring systems.</p> <p><input type="checkbox"/> Document measures or procedures to mitigate the extent and effects of such events.</p> <p><input type="checkbox"/> Mitigation or elimination of the risks and consequences of these events shall be at the discretion of the entities responsible for the reliability of the interconnected Transmission Systems.</p>
---	---	---

Footnotes to Table A2.

a) Applicable rating (A/R) refers to the applicable normal and emergency Facility thermal rating or system voltage limit as determined and consistently applied by the system or Facility owner.

-
- b) Planned or controlled interruption of generators or electric supply to radial customers or some local network Customers, connected to or supplied by the faulted component or by the affected area, may occur in certain areas without impacting the overall security of the interconnected transmission systems. To prepare for the next contingency, system adjustments are permitted, including curtailments of contracted firm (non-recallable reserved) electric power transfers.
 - c) Cascading is the uncontrolled successive loss of system elements triggered by an incident at any location. Cascading results in widespread service interruption which cannot be restrained from sequentially spreading beyond an area predetermined by appropriate studies.
 - d) Depending on system design and expected system impacts, the controlled interruption of electric supply to customers (Load Shedding), the planned removal from service of certain Generators, or the curtailment of contracted firm (non-recallable reserved) electric power transfers may be necessary to maintain the overall security of the Interconnected Transmission Systems.
 - e) A number of extreme contingencies that are listed under Category D and judged to be critical by the transmission planning entity (ies) will be selected for evaluation. It is not expected that all possible Facility Outages under each listed contingency of Category D will be evaluated.

3.3 Reliability Measures

3.3.1 Reliability indices

The fundamental attributes for probabilistic Reliability measures to be considered to evaluate risk of probable extreme events as discussed in Table A2 include:

- The Frequency of events (e.g. frequency of circuit overload – 0.72 events/year),
- Duration of events (e.g. duration of circuit overload – 2.5 hours/year), and
- Severity of events (how does event impact on load curtailment)

From these attributes other indices to quantify network performance can be calculated. To enable the definition of applicable indices, which may apply to the TCN, a number of concepts and definitions related to network, configuration and aspects influencing network performance are discussed below. These concepts and definitions are taken from Reference [1]¹.

3.3.2 Concepts and Definitions

Bulk system Reliability performance is normally measured in terms of the amount of Unreliability created by events in the bulk system, such as discussed in Table A2. “Unreliability” denotes the inability to provide the required supply to all customers connected to the bulk system. This involves loss of load to the bulk system, or maybe indirectly through the Distribution System.

Furthermore, a bulk system unreliability event can be defined as an event in the bulk system representing the inability to supply load to one or more customers. This inability may be a consequence of manual actions or of automatic operations of protective devices.

3.3.2.1 Manual Actions to Avoid Unreliability

These are defined as actions to:

- Adjust voltage and power flow through transformer tap changers,
- Re-dispatch generation,
- Reduce sales/ increase purchases from interconnections, and
- Manual actions such as switching operations.

Unreliability by Reducing Load.

These are defined as actions such as:

- Shed interruptible loads,
- Reduce system-wide voltage,
- Appeal to public or key customers to reduce demand, and

1

C.C. Fong, R. Billinton, R.O. Gunderson, P.M. O’Neill, J. Raksany, A.W. Schneider, Jr, B. Silverstein, “Bulk System Reliability – Measurement and Indices”, IEEE Trans. On Power Systems, Vol.4, No32, August 1989, pp. 829-835

-
- Institute Rotational Load Shedding.

3.3.2.2 Automatic Operations Signifying Unreliability

Automatic, intentional load shedding by devices designed to prevent or minimize a System Disturbance.

Interruption of supply due to bulk system Equipment Outages causing loss of continuity.

System Disturbance that is widespread load loss involving one or more of the following phenomena: system instability, cascading Outages, formation of islands, or undesirable Voltage or Frequency.

The manual actions to avoid unreliability listed above are usually taken to avoid violation of Operating Security limits in anticipation of further Outages that may cause Unreliability. The manual actions to confine Unreliability, on the other hand, are usually taken when a condition such as capacity or energy shortfall has already occurred, in order to minimize its consequences.

Summarizing, the proposed measurement system concentrates on the following Unreliability events:

- Interruption of supply due to loss of continuity,
- System Disturbance, and
- Automatic and Rotational Load Shedding.

3.3.2.3 Monitoring Points

With the above in mind, two types of monitoring points are defined. They are illustrated conceptually in Figure 1: and are defined as follows:

Radial Delivery Point: A radial delivery point is:

A low voltage bus of a Transformer. The bus radially supplies a Distribution System, or

A point in the bulk system, which is an interface between Transmission System and Directly Connected Customer-owned facilities. The point radially supplies the Directly Connected Customer.

Meshed Delivery Points: a set of points on the boundary between the Transmission System and a discrete part of the Distribution System.

Significant point: This is a bus or a point within the bulk system, where SO deems it important to monitor the reliability of service. This type of monitoring point recognizes that there may be special purpose monitoring points that are different from radial or meshed delivery points.

This distinction between radial and meshed delivery points is that interruption of radial delivery points result in load loss, whereas interruption of meshed delivery points does not always result in load loss but could result in inadequate service conditions.

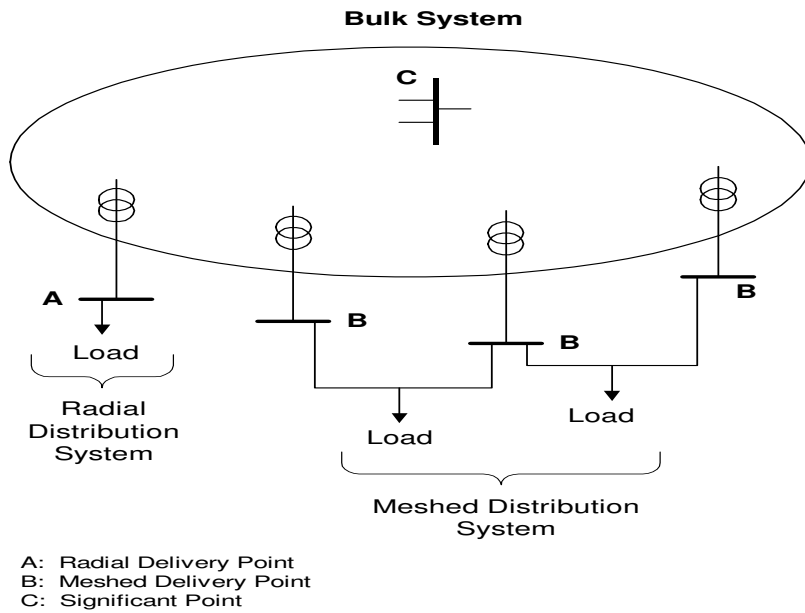

Figure 1: Measurement Points

Figure 2: further illustrates the two types of delivery points.

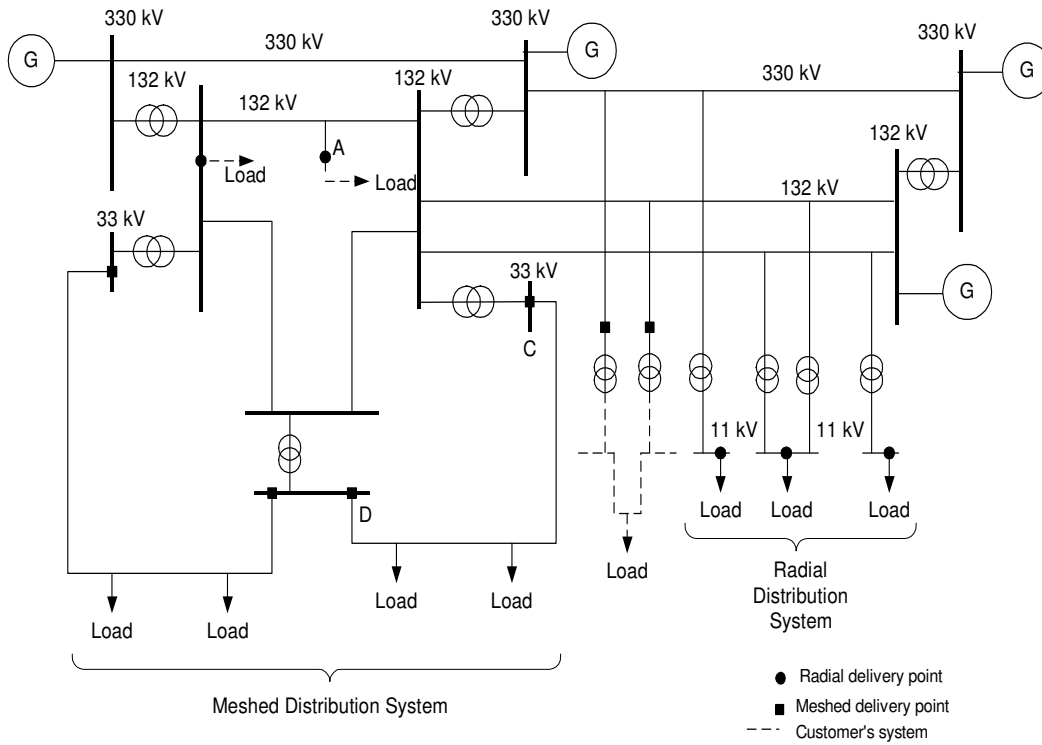

Figure 2: NEPA Bulk System

3.3.3 Basic Indices

Several fundamental indices are proposed. These can be expanded based on the TCN needs. All of these indices can be calculated for a defined recording period. The length of the period should be measured over multiple years to facilitate comparison.

Delivery Point Interruption Indices

(a) Individual Delivery Point Indices: For each delivery point (radial or meshed):

$$\text{Interruption Frequency} = \frac{\text{No. of Interruptions}}{\text{Period (Years)}}$$

$$\text{Annual Interruption Duration} = \frac{\text{Sum of Interruption Durations}}{\text{Period (Years)}}$$

$$\text{Average Duration per Interruption} = \frac{\text{Sum of Interruption Durations}}{\text{No. of Interruptions}}$$

$$\text{Annual Load Interrupted} = \frac{\text{Sum of MW Interrupted}}{\text{Period (Years)}}$$

$$\text{Annual Unsupplied Energy} = \frac{\text{Sum of Unsupplied Energy}}{\text{Period (Years)}}$$

$$\text{Delivery Point Interruption Severity} = \sum_i \frac{\text{Total Unsupplied Energy (MW minutes) in Year } i}{\text{Delivery Point Peak Load (MW) in Year } i}$$

(b) System-Wide Delivery Point Indices: For the bulk system and for each type of delivery point (radial or meshed):

$$\text{System Average Interruption Frequency} = \frac{\text{No. of Interruptions}}{\text{Delivery Point - years}}$$

$$\text{System Average Interruption Duration} = \frac{\text{Sum of Interruption Durations}}{\text{Delivery Point - Years}}$$

$$\text{System Average Restoration Duration} = \frac{\text{Sum of Interruption Durations}}{\text{Number of Interruptions}}$$

$$\text{System Average Load Interrupted} = \frac{\text{Sum of MW Interrupted}}{\text{Delivery Point - Years}}$$

$$\text{System Average Unsupplied Energy} = \frac{\text{Sum of Unsupplied Energy}}{\text{Delivery Point - Years}}$$

$$\text{System Interruption Severity} = \sum_i \frac{\text{Total Unsupplied Energy (MW Minutes) in Year } i}{\text{System Peak Load (MW) in Year } i}$$

Indices for Interruption of a Significant Point

For each significant point

$$\text{Interruption Frequency} = \frac{\text{No. of Interruptions}}{\text{Period (Years)}}$$

$$\text{Annual Interruption Duration} = \frac{\text{Sum of Interruption Durations}}{\text{Period (Years)}}$$

The monitoring of significant points is very specific to the needs of individual operations. “System-wide” average indices are not suggested here but may be considered, for groups of significant points.

Automatic and Rotational Load Shedding Indices

For each type of load shedding:

$$\text{Frequency} = \frac{\text{No. of Events}}{\text{Periods (Years)}}$$

$$\text{Load Shedding Severity} = \sum_i \frac{\text{Total Unsupplied Energy (MW Minutes) in Year } i}{\text{System Peak (MW) in Year } i}$$

These indices may also be calculated for a specific automatic scheme, to indicate its impact on bulk system reliability. The Load Shedding Severity Index is expressed in System Minutes.

System Disturbance Indices

For an individual System Disturbance:

$$\text{System Disturbance Severity} = \frac{\text{Unsupplied Energy (MW Minutes)}}{\text{Annual System Peak (MW)}}$$

This index is expressed in System Minutes. It is again fundamentally the same as the Bulk Power Energy Curtailment Index, but is applied to an individual System Disturbance in this case.

3.4 Value of Network Performance

Broadly speaking, the cost of an interruption from a customer’s perspective is related to the nature of the degree to which the activities interrupted are dependent on electricity. This dependency can be translated to a Customer Damage Function (CDF) that provides the severity of an interruption in relation to the duration of the interruption for a specific customer or group of customers. In turn, this dependency is a function of both customer and interruption characteristics.

Customer characteristics include:

- Type of customer;
- Nature of the customer’s activities;
- Size of operation, and other demographic data;
- Demand, and energy requirements; and
- Energy dependency as a function of time of day, etc.

Interruption characteristics include:

- Duration;
- Frequency;

-
- Time of occurrence of interruptions;
 - Whether an interruption is complete or partial;
 - If advance warning or duration information is supplied by the utility; and
 - Whether the area affected by the outage is localized or widespread.

3.4.1 Application of Customer Interruption Cost

The broadest application of a Customer Damage Function is its use to relate the composite customer losses to the socio-economic worth of electric service Reliability for an entire Utility Service Area². The cost estimates can be obtained by multiplying the Expected Unserved Energy to customers due to interruptions by a suitable factor, designated as the Interrupted Energy Assessment Rate (IEAR) expressed in \$/kWh.

3.4.2 Feedback into the System Planning Process

Some countries with extremely high reliability have attempted to introduce obligations on Distributors to make some form of payment to customers based on lost load. However this is not the common application of the Customer Damage Function.

The standard application of the Customer Damage Function is as feedback into the planning process. This is in order to support the planning security of supply analysis.

3.5 Conclusion

This Appendix serves as a guideline for the TCN to develop applicable Reliability measures and methodologies to maintain reliable operation of the Transmission System.

The Appendix provided fundamental concepts relating to:

- Transmission contingency criteria based of NERC standards,
- The measuring of Reliability indices in order to produce annual performance figures, and
- Guidelines with regard to the measurement of the value of network infrastructure.

²

Li Wenyuan, R. Billinton, "A Minimum Cost Assessment Method for Composite Generation and Transmission System Expansion Planning", IEEE Trans. On Power Systems, Vol.8, No.2, May 1993, pp. 628-635

4. APPENDIX 4A – RECORD OF NETWORK SAFETY PRECAUTIONS (RNSP)

[TCN] [_____ CONTROL CENTRE/SITE]

RECORD OF NETWORK SAFETY PRECAUTIONS REQUEST (RNSP-R)

(Requesting Safety Coordinator's Record)

RNSP NUMBER.....

PART 1

1.1 High Voltage Equipment Identification

Safety Precautions have been established by the implementing **Safety Coordinator** (or by another **User** on that **User's Equipment** connected to the implementing **Safety Coordinator's Equipment**) to achieve (in so far as it is possible from that side of the **Connection Point**) **Safety From** the Equipment on the following **High Voltage Equipment** on the **Requesting Safety Coordinator's Equipment**:

[State identity - name(s) and, where applicable, identification of the **high voltage** circuit(s) up to the **Connection Point**]:

Further **Safety precautions** required on the requesting **Safety Coordinator's Equipment** as notified by the implementing **Safety Coordinator**.

1.2 SAFETY PRECAUTIONS ESTABLISHED

(a) ISOLATION

[State the **Location(s)** at which **Isolation** has been established (whether on the implementing **Safety Coordinator's Equipment** or on the Equipment of another **User** connected to the implementing **Safety Coordinator's Equipment**). For each **Location**, identify each point of **Isolation**. For each point of **Isolation**, state the means by which the **Isolation** has been achieved, and whether, immobilised and **Locked**, **Caution Notice** affixed, other safety procedures applied, as appropriate.]

(b) **EARTHING**

[State the **Location(s)** at which **Earthing** has been established (whether on the implementing **Safety Coordinator's Equipment** or on the **System** of another **User** connected to the **implementing Safety Coordinator's System**). For each **Location**, identify each point of **Earthing**. For each point of **Earthing**, state the means by which **Earthing** has been achieved, and whether, immobilised and **Locked**, other safety procedures applied, as appropriate].

1.3 **ISSUE**

I have received confirmation from _____
(name of **Implementing Safety Coordinator**) at _____
(location) that the **Safety Precautions** identified in paragraph 1.2 have been established and that instructions will not be issued at his location for their removal until this **RNSP** is cancelled.

Signed(**Requesting Safety Coordinator**)
at(time) on (Date)

PART 2

2.1 **CANCELLATION**

I have confirmed to _____ (name of the
implementing **Safety Coordinator**) at _____
(location) that the **Safety Precautions** set out in paragraph 1.2 are no longer required and accordingly the **RNSP** is cancelled.

Signed(**Requesting Safety Coordinator**)
at(time) on (Date)

4. APPENDIX 4B – RECORD OF NETWORK SAFETY PRECAUTIONS

[TCN] [_____ CONTROL CENTRE/SITE]
RECORD OF NETWORK SAFETY PRECAUTIONS IMPLEMENTATION
(RNSP-I)
(Implementing Safety Coordinator's Record)

PART 1

RNSP NUMBER

1.1 High Voltage Equipment IDENTIFICATION

Safety Precautions have been established by the implementing **Safety Coordinator** (or by another **User** on that **User's Equipment** connected to the implementing **Safety Coordinator's Equipment**) to achieve (in so far as it is possible from that side of the **Connection Point**) **Safety from the System** on the following **High Voltage Equipment** on the **Requesting Safety Coordinator's Equipment**.

[State identity - name(s) and, where applicable, identification of the **high voltage** circuit(s) up to the **Connection Point**]:

Recording of notification given to the **Requesting Safety Coordinator** concerning further **Safety Precautions** required on the **Requesting Safety Coordinator's Equipment**.

1.2 SAFETY PRECAUTIONS ESTABLISHED

(a) ISOLATION

[State the **Location(s)** at which **Isolation** has been established (whether on the implementing **Safety Coordinator's Equipment** or on the **System** of another **User** connected to the implementing **Safety Coordinator's Equipment**). For each **Location**, identify each point of **Isolation**. For each point of **Isolation**, state the means by which the **Isolation** has been achieved, and whether, immobilised and **Locked**, **Caution Notice** affixed, other safety procedures applied, as appropriate.]

(b) **EARTHING**

[State the **Location(s)** at which **Earthing** has been established (whether on the implementing **Safety Coordinator's Equipment** or on the **System** of another **User** connected to the **Implementing Safety Coordinator's System**). For each **Location**, identify each point of **Earthing**. For each point of **Earthing**, state the means by which **Earthing** has been achieved, and whether, immobilised and **Locked**, other safety procedures applied, as appropriate].

1.3 **ISSUE**

I have confirmed to _____ (name of **Requesting Safety Coordinator**) at _____ (location) that the **Safety Precautions** identified in paragraph 1.2 have been established and that instructions will not be issued at my location for their removal until this **RNSP** is cancelled.

Signed(**Implementing Safety Coordinator**)
at(time) on (Date)

PART 2

2.1 **CANCELLATION**

L
I have received confirmation from _____ (name of the **Requesting Safety Coordinator**) at _____ (location) that the **Safety Precautions** set out in paragraph 1.2 are no longer required and accordingly the **RNSP** is cancelled.

Signed(**Implementing Safety Coordinator**)
at(time) on (Date)

(Note: This form to be of a different colour from RNSP-

4. APPENDIX 4C – RNSP ISSUE PROCESS

RSC – Requesting Safety Coordinator

Person requiring Safety Precaution from another User

ISC – Implementing Safety Coordinator

Person who co-ordinates provision of Safety Precautions

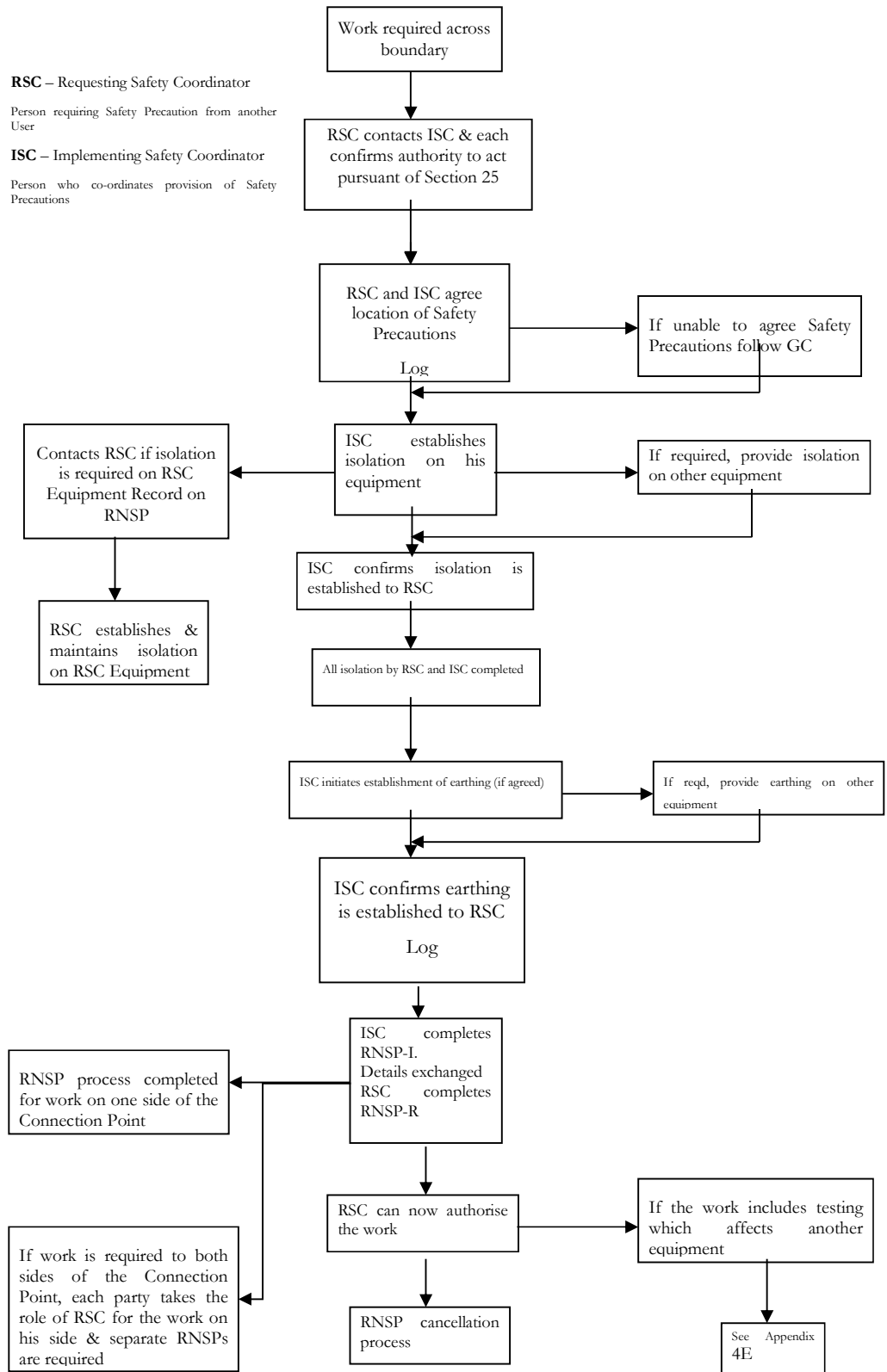

4. APPENDIX 4D – RNSP CANCELLATION PROCESS

RSC – Requesting Safety Coordinator

Person requiring Safety Precaution from another User

ISC – Implementing Safety Coordinator

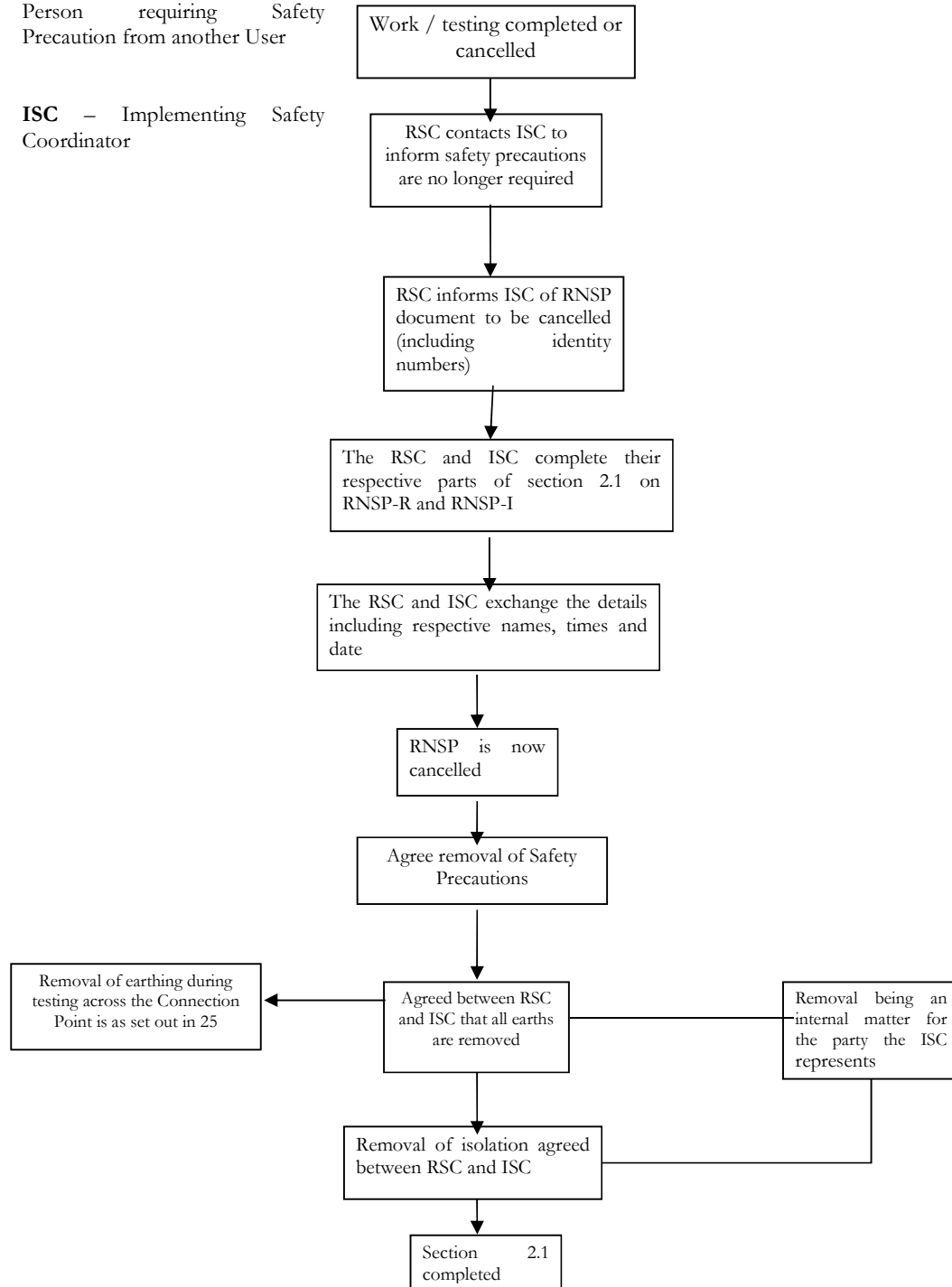

4. APPENDIX 4E – RNSP TESTING PROCESS

RSC – Requesting Safety Co-ordinator

Person requiring Safety Precaution from another User

ISC – Implementing Safety Co-ordinator

Person who co-ordinates provision of Safety Precautions

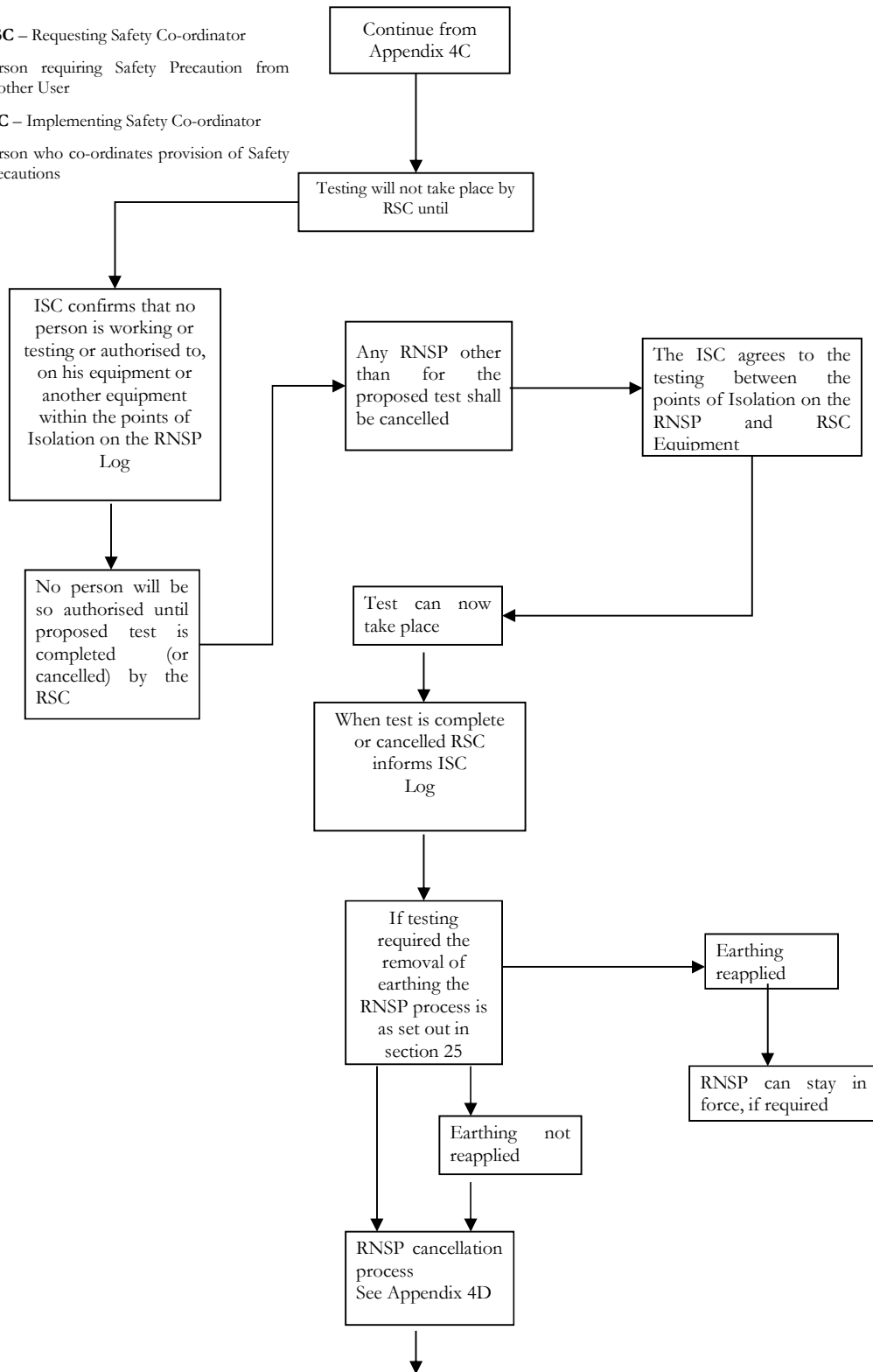

5. **APPENDIX 5 – DATA REGISTRATION REQUIREMENTS**

5.1 Introduction:

The System Planning specifies the technical and design criteria and procedures to be adopted by the TCN for the planning and development of the Transmission System. The Users of the Transmission System shall take the Data Registration for system planning into account for planning and development of their own Equipment or Apparatus.

5.1.1 Reinforcements and extensions to the Transmission Network arise due to many reasons of which a few are mentioned below:

1. A development on a User's Equipment or Apparatus already connected to the Transmission Network as a User development.
2. Introduction of a new Connection Point between a User's Equipment or Apparatus and the Transmission Network.
3. The need to increase Transmission Network capacity, removal of operational constraints, maintenance of Security Standards and meeting general increases in Demand.
4. Steady state and transient stability considerations.
5. Cumulative effects of any combination of the above four.

5.1.2 The work of such reinforcement and extension to the Transmission Network may also involve work at a connecting point (entry or exit) of a Power Station/Distributor to the Transmission Network.

5.1.3 The development of the Transmission Network must be planned in advance duly allowing sufficient lead time, considering the following:

1. Time required for obtaining all the necessary statutory approvals like Environmental Impact Assessment clearance, Forest clearance, Road or Railway clearance, clearance from aviation authorities, etc., and the right of way permissions wherever required,
2. Time required for detailed engineering, design and construction work to be carried out. This Network Planning, therefore, enforces the time scales for exchange of information between the TCN and the User(s). All the concerned parties, wherever appropriate, shall have due regard to the confidentiality of such information.

To enable the TCN to discharge its responsibilities under its Transmission Licence Conditions by conducting System Studies and preparation of perspective plans for Demand, Generation and Transmission Network expansion as detailed under the Grid Code, all Users of the Transmission Network shall furnish all the data to the TCN from time to time detailed below under Data Registration Requirement of Sections 8 and 12.

BASIC DATA REQUIREMENTS BASED ON SECTIONS 8, 12

Configurations of sites will vary hence the data requirements below are broadly phrased.

The interpretation of the requests for data is to be based on what the User owns or has necessary access to.

Ancillary Services (Power Quality Services)

The provision of Ancillary Services by Generators is critical to the secure operation of the Power System. The requirement to provide them is compulsory on Generators under the MR, GC and the Generator Licence.

On all timescales the Generator must provide the SO with its AS capability covering:

- 1) Reserve and Frequency Control
 - a) Reserve capability at all operating levels
 - i) Based on Frequency drop
 - ii) Response time
 - iii) Sustainability
 - b) automatic deloading capability at high frequencies
- 2) Voltage Control
 - a) Maximum and minimum MVAR levels
 - b) MVAR response to Voltage change
- 3) Black Start
 - a) This is a compulsory service.

PART-1 - GENERATION

To be furnished by Generators to TCN

5A Standard Planning Data (Generation)

THERMAL

I. GENERAL: -

<p>1. Site:</p>	<p>i. Furnish location map to scale showing roads, Railway lines, Transmission lines, Rivers, and reservoirs if any.</p> <p>ii. Fuel linkage (Natural Gas, Naptha, Oil pipeline)</p> <p>iii. Furnish information on means of Coal transport from mines or means of coal carriage if coal is to be brought from distance.</p> <p>iv. In case of other fuels, furnish details of sources of fuel and their transport.</p> <p>v. Water Sources (furnish information on availability of water for operation of the Power Station).</p> <p>vi. Environmental (State whether forest, lands mining clearance areas are affected).</p>
<p>2. Site Map: (To scale)</p>	<p>Showing area required for Power Station coal linkage, coal yard, water pipe line, ash disposal area, colony etc.</p>

3. Approximate period of construction.
4. Guaranteed Plant Load Factor.
5. Annual Generation.

II. Connection:

1. Connection Point	Furnish Single Line Diagram of the proposed connection with the system.
---------------------	---

2. Step up voltage for connection in kV

III. Station Capacity:

1. Total Power Station capacity (MW).	MW
2. Ancillary Services provided	

3. No. of Units and Unit size MW. State whether development will be carried out in phases and if so, furnish details.

4. Generating Unit Data:	<p>4 Steam Turbine- State Type, capacity, steam pressure, steam temperature, heat rate, efficiency etc.</p> <p>5 Generating Unit:</p> <p>a) Type</p> <p>b) Rating (MVA)</p> <p>c) Terminal Voltage (kV)</p> <p>d) Rated Power Factor</p> <p>e) Frequency Response Table</p> <p>f) Reactive Power capability (MVA_r) in the range 0.95 leading and 0.85 lagging.</p> <p>g) Short Circuit Ratio</p> <p>h) Direct axis transient reactance (% on MVA rating)</p> <p>i) Direct axis sub-transient reactance (% on MVA rating)</p>
--------------------------	---

	j) Auxiliary Power requirement 6 Generating Unit transformer / Station Transformer a) Rated Capacity (MVA) b) Voltage Ratio (HV/LV) c) Tap change range (+% to -%) d) On-load or off-load tap change e) Percentage Impedance (Positive Sequence at Full load).
--	--

5B Hydro Electric:

1. General:

1. Site	Furnish location map to scale showing roads, railway lines, Transmission lines
2. Site Map (To scale)	Map showing proposed dam, reservoir area, water pipe system, fore bay, powerhouse etc.
3. Submerged Area	Furnish information on area of villages submerged, forestland, agricultural land etc.
4. Approximate period of construction.	
5. Commissioning Date	
6. Annual Generation: expected water flow, expected Energy, annual load factor	

5B.1. Connection:

1. Connection Point	Furnish Single Line Diagram of proposed connection with the Transmission System
Step up voltage for connection kV	

5B.2. Station Capacity:

1. Total Power Station capacity MW	State whether development would be carried out in phases and if so furnish details
------------------------------------	--

2. No. of Units and unit size MW.	
-----------------------------------	--

5B.3 Generating Unit Data:

1. Operating Head (In Mtr)	Maximum Minimum Average
2. Turbine	State type and capacity
3. generator	a) Type b) Rating (MVA) c) Terminal Voltage (kV) d) Rated Power Factor e) Reactive Power capability (MVA _r) in the range of 0.95 leading and 0.85 of lagging. f) Short Circuit Ratio g) Direct axis transient reactance (% on rated MVA) h) Direct axis Sub-transient reactance (% on rated MVA) i) Auxiliary Power Requirement
4. generator – transformer	a) Type b) Rated Capacity (MVA) c) Voltage Ratio HV/LV d) Tap change Range (+ % to - %) e) On-load or off-load tap change f) Percentage Impedance (Positive sequence at Full load rating)

5C Detailed Planning Data (Generation)

5C.1 Thermal Power Stations

I. **General:**

1. Name of Power Station:
2. No. and capacity of Generating Units (MW):
3. Ratings of all major Equipment:

-
- a) Boilers and Major accessories (Steam temperature/pressure)
 - b) Coal Mill (KW)
 - c) Feed water Pumps (KW)
 - d) Major Fans (KW)
 - e) Turbines
 - f) Alternators
 - g) Generating Unit Transformers (MVA)
 - h) Station Transformers
4. Auxiliary Transformers (MVA)
 5. Single Line Diagram of Power Station and switchyard.
 6. Relaying and metering diagram.
 7. Neutral Grounding of Generating Units.
 8. Excitation control (type - E.g. Static Excitation System, Fast Brushless)
 9. Earthing arrangements with earth resistance values.

5C.2. Protection and Metering:

1. Full description including settings for all relays and protection systems installed on the generating Unit, Generating Unit Transformer, Auxiliary Transformer and electrical motor of major Equipment listed.
2. Full description including settings for all relays installed on all outgoing circuits from Power Station substation switchyard, tie circuit breakers, incoming circuit breakers.
3. Full description of inter-tripping of Breakers at the point or points of Connection with the Transmission System.
4. Most probable fault clearance time for electrical faults on the User's system.
5. Full description of operational and commercial metering schemes.

5C.3 Switchyard:

1. In relation to interconnecting transformers between High Voltage Transmission System and the Generating Unit:
 - a) Rated MVA
 - b) Voltage Ratio
 - c) Vector Group
 - d) Positive sequence reactance (maximum, minimum, normal Tap(% on MVA)
 - e) Positive sequence resistance (maximum, minimum, normal Tap (% on MVA)
 - f) Zero sequence reactance (% on MVA)
 - g) Tap changer Range (+ % to - %) and steps
 - h) Type of Tap changer (off-load/on-load)
2. In relation to switchgear including circuit breakers, isolators on all circuits connected to the points of connection:
 - a) Rated Voltage (KV)

-
- b) Type of Breaker (MOCB/ABCB/SF6)
 - c) Rated short circuit breaking current (kA) 3 Phase
 - d) Rated short circuit breaking current (kA) 1 Phase
 - e) Rated short circuit making current (kA) 3 Phase
 - f) Rated short circuit making current (kA) 1 Phase
 - g) Provisions of auto reclosing with details.
3. Lightning Arresters: technical data.
 4. Communication- Details of PLC Equipment installed at points of connections.
 5. Basic Insulation Level (kVp).
 - a) Busbar.
 - b) Switchgear.
 - c) Transformer Bushings.
 - d) Transformer windings.

5D. Generating Units: -

5D.1. Parameters of Generating Units:

1. Rated terminal voltage (KV)
2. Rated MVA
3. Rated MW
4. Inertia constant (MW Sec./MVA) of generator, exciter and turbine
5. Short circuit ratio
6. Direct axis synchronous reactance (% on MVA)
7. Direct axis transient reactance (% on MVA)
8. Direct axis sub-transient reactance (% on MVA)
9. Quadrature axis synchronous reactance (% on MVA)
10. Quadrature axis transient reactance (% on MVA)
11. Quadrature axis sub-transient reactance (% on MVA)
12. Direct axis transient open circuit time constant (Sec)
13. Direct axis sub-transient open circuit time constant (Sec)
14. Quadrature axis transient open circuit time constant (Sec)
15. Quadrature axis sub-transient open circuit time constant (Sec)
16. Stator Resistance (Ohm)
17. Stator leakage reactance (Ohm)
18. Stator time constant (Sec)
19. Rated Field current (A)

-
20. Open Circuit saturation characteristic for various terminal voltages giving the exciting current to achieve the same.
 21. Generating Unit Capability Chart
 22. SCADA details
 23. Communication details

5D.2 Parameters of Excitation control system:

1. Type of Excitation
2. Maximum Field voltage
3. Minimum Field voltage
4. Rated Field voltage
5. Gain Factor
6. Feedback Strength
7. Time constant for control amplifier
8. Time constant for Exciter
9. Time constant for Feedback
10. Output voltage of control amplifier
11. Maximum Output voltage of control amplifier
12. Minimum Output voltage of control amplifier
13. Details of excitation loop in Block Diagrams showing transfer functions of individual elements using IEEE symbols along with set values.
14. Dynamic characteristics of over - excitation Limiter
15. Dynamic characteristics of under -excitation Limiter

Note: Using IEEE Committee Report symbols the following parameters shall be furnished: D , A , BS_x , K_a , K_e , K_f , T_a , Y_f , $V_r(\max)$, $V_r(\min)$, S_a , S_b .

5E. Parameters of Governor:

1. Governor average gain (MW/Hz)
2. Speeder motor setting range
3. Time constant of steam or fuel Governor valve
4. Governor valve opening limits.
5. Governor valve rate limits.
6. Time constant of Turbine

-
7. Governor Block Diagram showing transfer functions of individual elements using IEEE symbols along with set values.

5F. Plant Performance:

1. Daily Demand Profile (Last Year)	Peak and Average in time marked 30 minutes throughout the day.
2. Daily Demand Profile (forecast)	In time marked 30 minutes throughout the day.
3. Units Generated (MWh)	
4. Units consumed in Auxiliaries (MWh)	
5. Units supplied from system to Auxiliary Load	
6. Seasonal Generation	

5G. Operational Parameters:

1. Min. notice required for Synchronizing a Generating Unit.
2. Min. time between Synchronizing different Generating Units in a Power Station.
3. The minimum block load requirements on Synchronizing.
4. Time required for Synchronizing a Generating Unit for the following conditions:
 - a) Hot
 - b) Warm
 - c) Cold
5. Maximum Generating Unit loading rate for the following conditions:
 - a) Hot
 - b) Warm
 - c) Cold
6. Maximum Generating Unit deloading rate
7. Minimum on-load time
8. Minimum off-load time
9. Minimum load
10. Minimum load without oil support (MW)

-
11. Any staffing constraints (e.g. only day and evening shifts are employed so no overnight operation)

5H. Hydroelectric Stations:

I. General:

1. Name of Power Station:
2. No. and capacity of Units (MVA)
3. Expected level of Generation
4. Impeller type: only in exceptional circumstances will non-Kaplan machines be accepted on the system.
5. Reserve capability: full details
6. Period of Generation (in months) per year
7. Whether the Plant is based on water released from dam/canal for irrigation purposes
8. Rating of all major Equipment.
 - a) turbine (HP):
 - b) generators (MVA):
 - c) generator transformers (MVA):
 - d) auxiliary transformers (MVA):
9. Single Line Diagram of Power Station and switchyard.
10. Relaying and metering diagram.
 - a) Neutral grounding of generator.
 - b) Excitation control.
 - c) Earthing arrangements with earth resistance values.
11. SCADA details
12. Communication details

II. Reservoir Data:

Salient features:

1. Type of Reservoir: Multipurpose/Power only
2. Operating Table with:
 - a) Area capacity curves,
 - b) Unit capability at different net heads,
 - c) FRL/MDDL.

III. Protection:

-
1. Full description including settings for all relays and protection systems installed on the Generating Units, generator transformer, Auxiliary transformer and electrical motor of major Equipment {included}, but not limited to those listed under General.
 2. Full description including settings for all relays installed on all outgoing feeders from Power Station switchyard, tie breakers, and incoming breakers.
 3. Full description of inter-tripping of breakers at the point or points of Connection with the Transmission System.
 4. Most probable fault clearance time for electrical faults on the User's system.

IV. Switchyard:

1. Interconnecting Transformers:

- a) Rated MVA
- b) Voltage Ratio
- c) Vector Group
- d) Positive sequence reactance for maximum, minimum, normal Tap (% on MVA)
- e) Positive sequence resistance of maximum, minimum, normal Tap (% on MVA).
- f) Zero sequence reactance (% on MVA)
- g) Tap changer Range (+ % to - %) and steps
- h) Type of Tap changer (off-load/on-load)

2. Switchgear (including circuit breakers, Isolators on all circuits connected to the points of connection):

- a) Rated voltage (KV)
- b) Type of Breaker (MOCB/ABCB/SF6)
- c) Rated short circuit breaking current (KA) 3 Phase.
- d) Rated short circuit breaking current (KA) 1 Phase.
- e) Rated short circuit making current (KA) 3 Phase.
- f) Rated short circuit making current (KA) 1 Phase.
- g) Provisions of auto reclosing with details.
- h) Details of Instrument Transformers.

3. Lightning Arresters, Technical data.

4. Communications: Details of communications Equipment installed at points of connections.

5. Basic Insulation level (KV):

- a) Bus bar
- b) Switchgear
- c) Transformer Bushings
- d) Transformer Windings

6. Generating Units:

i. Parameters of generator:

-
- a) Rated terminal voltage (KV)
 - b) Rated MVA
 - c) Rated MW
 - d) Inertia constants (MW Sec./MVA) of generator, exciter and turbines
 - e) Short circuit ratio
 - f) Direct axis synchronous reactance. (% on MVA)
 - g) Direct axis transient reactance. (% on MVA)
 - h) Direct axis sub-transient reactance (% on MVA)
 - i) Quadrature axis synchronous reactance (% on MVA)
 - j) Quadrature axis sub-transient reactance (% on MVA)
 - k) Direct axis transient open circuit time constant (SEC)
 - l) Direct axis sub-transient open circuit time constant (SEC)
 - m) Stator Resistance (Ohm)
 - n) Stator leakage reactance (Ohm)
 - o) Stator time constant (Sec)
 - p) Rated Field current (A)
 - q) Open Circuit saturation characteristics of the generator for various terminal voltages giving the compounding current to achieve this.
 - r) Generating Unit Capability Chart

ii. Type of Turbine:

- a) Type:
- b) Operating Head (Mtr.)
- c) Discharge with Full Gate Opening (Cumecs)
- d) Speed Rise on total Load throw off (%)

iii. Parameters of Excitation Control system

(AS APPLICABLE TO THERMAL POWER STATIONS)

iv. Parameters of Governor

(AS APPLICABLE TO THERMAL POWER STATIONS)

7. Operational parameters:

- a) Minimum notice required for Synchronizing a Generating Unit.
- b) Minimum time between Synchronizing different Generating Units in a Power Station.
- c) Minimum block load requirements on Synchronizing.
- d) Maximum and minimum flow rates
- e) Equivalent maximum and minimum generation at various head levels
- f) Any inter Generating Unit constraints.

5I. Planning Data Generation

(For submission on request by Transmission Licensee)

5I.1 for Thermal Power Stations:

5I.1.1 General:

1. Detailed Project report.
2. Status Report:
 - a) Land
 - b) Fuel type
 - c) Cooling Method
 - d) Environmental clearance
 - e) Rehabilitation of displaced persons.
3. Approval by Nigeria Electricity Regulatory Commission
4. Financial tie-up in place.
5. Connection Agreement and Use of System Agreement in place

5I.1.2 Connection:

1. Report of studies of parallel operation with Transmission System:
 - a) Load flow studies
 - b) Stability studies
 - c) Short Circuit studies
2. Proposed connection with Transmission System:
 - a) Voltage
 - b) No. of circuits
 - c) Connection Point

5I.2. Hydroelectric Power Stations:

5I.2.1 General:

1. Detailed Project Report
2. Status Report
 - a) Topographical survey
 - b) Geological Survey
 - c) Land
 - d) Environmental clearance
 - e) Rehabilitation of displaced persons
3. Approval by Nigeria Electricity Regulatory Commission
4. Financial Tie-up in place.
5. Connection Agreement and Use of System Agreement in place

5I.2.2 Connection:

1. Reports of studies for parallel operation with TCN System.
 - a) Load flow studies
 - b) Short Circuit studies
 - c) Stability studies
2. Proposed Connection with Transmission System:
 - a) Voltage
 - b) No. of Circuits.
 - c) Connection Point.

5J. Standard Planning Data for Power Park Modules:

I General:	
1. Site:	<ol style="list-style-type: none">i. Furnish location map to scale showing roads, Railway lines, Transmission lines, Rivers, and reservoirs if any.ii. Environmental (State whether forest, lands mining clearance areas are affected).
2. Site Map: (To scale)	Showing area required for Power Park Module, main Plant, buildings and location of Power Park Units.

3. Approximate period of construction. 4. Estimated Plant Load Factor. 5. Estimated Annual Generation.	
<u>II. Connection:</u>	
3. Connection Point	Furnish Single Line Diagram of the proposed connection with the system.
4. Step up voltage for connection in kV	
<u>III. Station Capacity:</u>	
5. Total Power Park Module capacity (MW). 6. Ancillary Services provided	State the total installed capacity (in MW) of Power Park Units, and the total export capacity (in MW) at the Connection Point
7. No. of Power Park Units and Unit size MW.	State whether development will be carried out in phases and if so, furnish details.
8. Power Park Module and Power Park Unit Data:	7 Generator: a) Type b) Rating (MVA) c) Terminal Voltage (kV) d) Rated Power Factor e) Frequency Response Table (where applicable) f) Reactive Power capability chart (MW/MVAr) at the Power Park Unit Terminals. 8 Power Park Module a) Power Park Module capability chart (MW/MVAr) at the Connection Point b) Grid Transformer(s)

	<ul style="list-style-type: none"> i. Rated Capacity (MVA) ii. Voltage Ratio (HV/LV) iii. Tap change range (+% to - %) iv. On-load or off-load tap change v. Percentage Impedance (Positive Sequence at Full load).
--	--

5K. Detailed planning data for Power Park Modules:

5K.1 General:

1. Name of Power Park Module:
2. No. and capacity of Power Park Units (MW):
3. Ratings of all major Equipment:
 - a) Power Park Unit Transformers (MVA)
 - b) Power Park Module Grid Transformers (MVA)
 - c) Auxiliary Transformers (MVA)
 - d) Cables
 - e) Additional reactive Equipment (e.g. STATCOM / SVC / shunt elements)
4. Single Line Diagram of Power Park Module and switchyard.
5. Relaying and metering diagram.
6. Neutral Grounding of Power Park Units.
7. Voltage Control methodology (e.g. utilising Power Park Units / STATCOM / SVC / shunt elements etc.)
8. Earthing arrangements with earth resistance values.

5K.2 Protection and Metering:

1. Full description including settings for all relays and protection systems installed on the Power Park Module, including but not limited to, those on the Power Park Unit, Generating Unit Transformer, Auxiliary Transformer, Power Park Module Grid Transformer and cable networks.
2. Full description including settings for all relays installed on all outgoing circuits from Power Park Module substation switchyard, tie circuit breakers, incoming circuit breakers.
3. Full description of inter-tripping of Breakers at the Connection Point(s) with the Transmission System.
4. Most probable fault clearance time for electrical faults on the User's system.
5. Full description of operational and commercial metering schemes.

5K.3 Switchyard:

1. In relation to interconnecting transformers between High Voltage Transmission System and the Power Park Module MV system:
 - a) Rated MVA
 - b) Voltage Ratio
 - c) Vector Group
 - d) Positive sequence reactance (maximum, minimum, normal Tap(% on MVA)
 - e) Positive sequence resistance (maximum, minimum, normal Tap (% on MVA)
 - f) Zero sequence reactance (% on MVA)
 - g) Tap changer Range (+ % to - %) and steps
 - h) Type of Tap changer (off-load/on-load)
2. In relation to transformers on individual Power Park Units:
 - i) Rated MVA
 - j) Voltage Ratio
 - k) Vector Group
 - l) Positive sequence reactance (maximum, minimum, normal Tap(% on MVA)
 - m) Positive sequence resistance (maximum, minimum, normal Tap (% on MVA)
 - n) Zero sequence reactance (% on MVA)
 - o) Tap changer Range (+ % to - %) and steps
 - p) Type of Tap changer (off-load/on-load)
3. In relation to switchgear including circuit breakers and isolators in all areas on of the Power Park Module and at the Connection Point(s):
 - a) Rated Voltage (KV)
 - b) Type of Breaker (MOCB/ABCB/SF6)
 - c) Rated short circuit breaking current (kA) 3 Phase
 - d) Rated short circuit breaking current (kA) 1 Phase
 - e) Rated short circuit making current (kA) 3 Phase
 - f) Rated short circuit making current (kA) 1 Phase
 - g) Provisions of auto reclosing with details.
4. Lightning Arresters: technical data.
5. Communication- Details of PLC Equipment installed at Connection Point(s).
6. Basic Insulation Level (kVp).
 - e) Busbar.
 - f) Switchgear.
 - g) Transformer Bushings.
 - h) Transformer windings.

5K.4 Power Park Module and Power Park Units: -

5K.4.1 Parameters of Power Park Units:

-
1. Rated terminal voltage (KV)
 2. Rated MVA
 3. Rated MW
 4. Power Park Unit Capability Chart (MW/MVAr at terminals)

5K.4.2 Parameters of Power Park Module

1. SCADA details
2. Communication details
3. Control point details and location / contact details
4. Description of Voltage Control / Reactive Power Control methodology and associated Equipment

5K.5 Power Park Module Study Requirements

Study reports to be submitted:

1. Short circuit report
2. Reactive capability load flow report
3. Voltage Control / Reactive Power Control system performance report
4. Fault Ride Through report
5. Harmonic studies report

5K.6 Power Park Module Model Requirements

1. Dynamic model of Power Park Module

5K.7. Plant Performance:

1. Daily Demand Profile (Last Year)	Peak and Average in time marked 30 minutes throughout the day.
2. Daily Demand Profile (forecast)	In time marked 30 minutes throughout the day.

3. Units Generated (MWh)	
4. Units consumed in Auxiliaries (MWh)	
5. Units supplied from system to Auxiliary Load	
6. Seasonal Generation	

5K.8 Operational Parameters:

1. Min. notice required for Synchronizing a Power Park Module
2. Min. time between Synchronizing different Power Park Units in a Power Station
3. The minimum block load requirements on Synchronizing
4. Maximum Power Park Module loading rate
5. Maximum Power Park Module deloading rate
6. Minimum on-load time
7. Minimum off-load time
8. Minimum load
9. Any staffing constraints (e.g. only day and evening shifts are employed so no overnight operation)

5L Planning Data for Power Park Modules:

(For submission on request by Transmission Licensee)

5L.1 General:

1. Detailed Project report.
2. Status Report:
 - a) Land
 - b) Fuel type
 - c) Environmental clearance
 - d) Rehabilitation of displaced persons.
3. Approval by Nigeria Electricity Regulatory Commission
4. Financial tie-up in place.
5. Connection Agreement and Use of System Agreement in place

5L.2 Connection:

1. Report of studies of parallel operation with Transmission System:
 - a) Load flow studies (including Reactive Power capability)
 - b) Stability studies (Fault Ride Through)
 - c) Short Circuit studies

2. Proposed connection with Transmission System:
 - a) Voltage
 - b) No. of circuits
 - c) Connection Point

-
1. Line Data: Furnish length of line and voltages within the area.
 2. Sub-station Data: Furnish details of 132/33 kV Sub-station, 33/11 KV, Sub-stations, capacitor or reactor installations:

IV. Loads:

1. Loads drawn at points of connection:
2. Details of loads fed at 11kV or above: Give name of consumer, voltage of supply, contract demand and name of Grid Sub-station from which line is drawn, length of line from Grid Sub-station to consumer's premises.

V. Demand Data (For all Loads 1 MW and above):

1. Type of load: State whether furnace loads, rolling mills, traction loads, other industrial loads, pumping loads etc.
2. Rated voltage:
3. Electrical loading of Equipment: State number and size of motors, types of drive and control arrangements.
4. Sensitivity of load to voltage and Frequency of supply:
5. Power Factor of load for night and day
6. Maximum harmonic content of load:
7. Average and maximum phase unbalance of load:
8. Nearest sub-station from which load is to be fed:
9. Location map to scale: Map shall show the location of load with reference to lines and sub-stations in the vicinity.

VI. Load Forecast Data:

1. Peak load and energy forecast for each category of loads for each of the succeeding 5 years.
2. Details of methodology and assumptions on which forecasts are based.

-
3. If supply is received from more than one sub-station, the sub-station breaks up of peak load and energy projection for each category of loads for each of the succeeding 5 years along with estimated daily load curve.
 4. Details of load 1MW and above.
 - a) Name of prospective consumer.
 - b) Location and nature of load/complex.
 - c) Sub-station from which to be fed.
 - d) Voltage of supply.
 - e) Phasing of load.

6B. Detailed Planning Data: Distribution

6B.1 General:

1. Distribution map (To scale). Showing all lines up to 11 kV and sub-stations belonging to the Licensee.
2. Single Line Diagram of distribution system (showing distribution lines from points of connection with transmission system 132/33 kV Sub-station, 33/11 kV sub-station, consumer bus if fed directly from Transmission System)
3. Numbering and nomenclature of lines and sub-stations (Identified with feeding Grid sub-stations of the Transmission System and concerned 33/11 kV sub-station of supplier).
4. Monitoring Distribution Losses (Methods adopted for reduction of losses to be stated).

6B.2 Connection:

1. Points of connection (Furnish details of existing arrangement of Connection)
2. Details of metering at points of connection.

6B.3 Loads:

1. Connected Load (Category-wise) - Furnish consumer details, No. of consumers category-wise details of loads 1 MW and above)
2. Information on diversity of load and coincidence factor.
3. Daily demand profile (current and forecast) on each 33kV/11kV sub-station.
4. Cumulative Demand Profile of Distribution (current and forecast)

6B.4 Detailed Planning Data: Distribution

(For submission on request by the TCN)

I. General:

1. Detailed Project Report (For new and system improvement schemes)
2. Status Report
 - (a) Load Survey
 - (b) Load forecast for next five years
3. Single Line Diagram showing proposed new lines and Sub-stations

II. Connection:

1. Points of connection as applied for
 - (a) New
 - (b) Upgrading existing connection
2. Changes in metering at points of connection
3. SCADA details
4. Communication details

III. Loads:

1. Details of loads as per the forecast in next 5 years
2. Distribution of loads 33/11 kV Sub-station wise projected for next 5 years
3. Details of major loads of 1 MW and above to be contracted for next 5 years

IV. Improvement Schemes for reduction of Distribution Losses:

1. Statement of estimated Distribution losses for next five years
2. Brief indication of improvement scheme for reduction of losses (excerpts from Detailed Project Report)
 - (a) New lines
 - (b) Upgrading of lines
 - (c) New Sub-station/Upgrading of Sub-stations
 - (d) Rearrangement of loads
 - (e) Installation of capacitors.

7. APPENDIX 7 – NETWORK EXPANSION PLANNING DATA

REQUIREMENTS:

To enable the TCN to discharge its responsibilities under its Transmission Licence by conducting System Studies and preparation of plans for Demand, Generation and Transmission Network expansion as detailed under the Grid Code, all Users of the Transmission Network shall furnish all the data to the TCN from time to time detailed below under Data Registration Requirement of Sections 8 and 12.

[In pursuance of Sections 8 and 12 of the Grid Code, items in this Appendix must be included in the yearly 5 year planning study report of TCN and provided to Users (e.g. Generating Companies, Discos) on an annual basis.]

7A. Standard Planning Data: Transmission

This is a list of planned circuits

Note: - The compilation of the data is currently the internal matter of the Licensee, and as such the Licensee shall make arrangements for getting the required data from different Departments of the Licensee to up-date its standard planning Data in the format given below:

1. Name of the line: (Indicating Power Stations and Sub-stations to be connected)
2. Voltage of line (KV):

-
3. No. of Circuits:
 4. Route length (Circuit KM):
 5. Conductor sizes:
 6. Line parameters (PU on 100 MVA base or ohmic values):
 - (a) Resistance/KM
 - (b) Series Inductive Reactance /KM
 - (c) Shunt Susceptance/KM
 7. Approximate power flow MW & MVA: MVA at both ends
 8. Terrain of route: Give information regarding nature of terrain i.e., forestland, fallow land, agricultural and river basin, hill slope etc.
 9. Route Map (to scale): Furnish topographical map showing the proposed route showing existing power lines and telecommunication lines
 10. Purpose of connection:
 11. Approximate period of construction:

7B Detailed System Data: Transmission

7B.1 General:

- (a) Single Line Diagram of the User's system from 132 KV bus and above at grid sub-station:
- (b) Name of sub-station
- (c) Power Station connected
- (d) Number and length of Circuits
- (e) Interconnecting transformers
- (f) Sub-station bus layouts
- (g) Power Transformers
- (h) Reactive compensation Equipment
 1. The details of capacitors installed
 2. Additional capacitors to be commissioned along with additional loads.
- (i) Lightning Arresters
- (j) Bus and/or Line Reactors

-
- (k) Series Capacitors

7B.2 Sub-station layout diagrams showing:

- (a) Bus bar layouts
- (b) Electrical circuitry, lines, cables, transformers, switchgear etc.
- (c) Phasing arrangements
- (d) Earthing arrangements
- (e) Switching facilities and interlocking arrangements
- (f) Operating voltages
- (g) Numbering and nomenclature
 - i. Transformers
 - ii. Circuits
 - iii. Circuit Breakers
 - iv. Isolating switches

7B.3.1 Line parameters: (For all Circuits)

- (a) Designation of line
- (b) Length of line (KM)
- (c) No. of circuits, size, type and number of conductors, thermal rating
- (d) Per Circuit values
 - i. Operating voltage (KV)
 - ii. Positive phase sequence reactance - ohms/KM
 - iii. Positive phase sequence resistance - ohms/KM
 - iv. Positive phase sequence susceptance - mhos/KM
 - v. Zero phase sequence reactance - ohms/KM
 - vi. Zero phase sequence resistance - ohms/KM
 - vii. Zero Phase sequence susceptance - mhos/KM

7B.3.2 Transformer parameters: (For all transformers)

- (a) Rated MVA and sharing ratio if multiple voltage
- (b) Voltage Ratio(s)
- (c) Vector Group
- (d) Positive sequence reactance on rated MVA base (Max., min. & normal)

-
- (e) Positive sequence resistance on rated MVA base (max., min. & Normal)
 - (f) Zero sequence reactance on rated MVA base
 - (g) Tap change range (+% to -%) and steps
 - (h) Details of tap changer (off-load/on-load)
 - (i) Neutral Grounding Transformer/Resistor Values

7B.3.3 Equipment Details: (For all Sub-stations):

- (a) Circuit Breakers
- (b) Isolating switches
- (c) Current Transformers
- (d) Potential Transformers
- (e) Lightning Arresters

7B.3.4 Relaying and metering:

- (a) Relay protection installed for all transformers and Feeders along with their settings and level of co-ordination with other Users.
- (b) Metering Details:
- (c) SCADA details
- (d) Communication details

7B.4.1 Demand Data: (For all sub-stations)

- (a) Demand Profile (Peak and lean load)
 - i. Current
 - ii. Forecast for next 5 years

7B.4.2 Reactive Compensation Equipment:

- (a) Type of Equipment (fixed or variable)
- (b) Capacities and/or inductive rating (Voltage and MVA_r) or its operating range.
- (c) Details of control
- (d) Connection Point to the system.

7B.5 Detailed Planning Data (Transmission)
(To be submitted by TSP upon request from the SO)

7B.5.1 General:

1. Detailed Project Report (For new and System Improvement Schemes)
2. Status Report
3. Line:
 - a) Route Survey
 - b) Forest Clearance
4. Sub-Stations
 - a) Land
 - b) Environmental Clearance
 - c) Financial Tie-up

7B.5.2 Connection:

1. Single Line Diagram showing position of connection
2. Sub-station layout diagram
 - a) New
 - b) Addition and Alteration
3. Changed parameters for revised system studies by SO
4. Connection Point
 - a) Voltage
 - b) Length of circuit
 - c) Circuit parameters
 - d) PLC facilities
 - e) Relaying with inter tripping arrangements to inter trip system breaker at Connection Point to isolate on fault
 - f) Metering at Connection Point.

8. APPENDIX 8: CIVIL EMERGENCIES

Upon the declaration of civil emergency affecting the production, transportation and/or consumption of electrical power by competent authority in Nigeria, it is the obligation on the TCN to prepare and maintain plans for mitigating the effects of any civil emergency and fuel security situation, which may occur in accordance with the Electricity Supply Emergency directive issued by the Industry Regulator. That directive shall describe the steps which authority might take to deal with an electricity production and supply emergency situation and sets down the actions which Companies in the Electricity Supply Industry should plan to take and which may be needed or required in order to deal with such an emergency.

In an electricity emergency it may become necessary to restrict User's Demand for and consumption of electricity and may be achieved by one or more of the following methods:

- a) Appeals by the Industry Regulator to the public for voluntary restraint
- b) The issue of order(s) under competent Nigeria Authority requiring restrictions on consumption by industry, commerce and other Users deem appropriate.
- c) The issue of order(s) under competent Nigeria Authority requiring rotating disconnections and associated restrictions.

In the event that the Industry Regulator issues directions to TCN to implement rotating disconnections, the TCN will establish an Emergency Coordinating Centre and as soon as possible establish communications with such relevant Users as is necessary to ensure operational liaison. The plans to be implemented will be similar or separate from the schemes outlined in Section 18 of the Grid Code.

The plans shall make provision for the need to maintain supply, so far as practicable, to consumers in protected categories. For the purpose of the Grid Code Security installations, Communication Facilities and Hospitals and other designated Facilities deemed appropriate by competent Nigeria Authority shall be deemed to be protected Facility in accordance with the provisions of the Civil Emergency Order.

9. APPENDIX 9: GRID CODE REVIEW PANEL

9.1 The Nigerian Electricity Regulatory Commission (NERC) shall establish the Grid Code Review Panel. The Panel shall be responsible for developing and improving the Code through regular review, consultation, research and the consideration of amendment submissions by Users, TSP, SO or other interested parties and other methodologies deemed appropriate from time to time. The funding and maintenance of the Panel shall be the responsibility of the SO, including the location of the Panel's secretariat.

The Panel shall be a standing body to carry out the functions referred to in paragraph 9.2.

9.2 The Grid Code Review Panel shall:

- i. keep the Grid Code and its working under review;
- ii. review all amendments to the Grid Code which NERC or any User or TCN may wish to submit for consideration by the Panel from time to time;
- iii. publish recommendations as to amendments to the Grid Code that TCN or the Panel feels are necessary or desirable and the reasons for the recommendations;
- iv. issue guidance in relation to the Grid Code and its implementation, performance and interpretation when asked to do so by any User;
- v. consider what changes are necessary to the Grid Code arising out of any unforeseen circumstances referred to it by TCN; and
- vi. consider and identify changes to the Grid Code to remove unnecessary Section(s) or clause(s) that are of irrelevant to the effective operation of the Nigeria Power System.

9.3 The Panel shall consist of:

- i. the Head of System Operations shall be Chairman;
- ii. 4 members appointed by TCN from Network, System, Market and Safety Operations of TCN;
- iii. a person appointed by the Nigerian Electricity Regulatory Commission; and
- iv. 3 persons representing Generating Companies one of which must represent hydro Power Stations;
- v. 3 persons representing the Distribution Companies;
- vi. a person representing the Rural Electrification Agency;
- vii. a person representing Directly Connected Customers and also Customers with a maximum demand greater than or equal to 1MW; and
- viii. a person representing the Nigerian Bulk Electricity Trader.

Each of the Panel members shall be appointed by their respective industry sector pursuant to the rules issued by the Panel in 9.4.

9.4 The Panel shall establish and comply at all times with its own rules and procedures relating to the conduct of its business, which shall be approved by NERC. Meetings of the Panel shall be held at regular intervals and at least every month at such time and place as the Panel shall decide.

9.5 The Panel shall consult in writing all Industry Stakeholders and Operators which are liable to be affected in relation to all submitted amendments to the Grid Code and shall review and discuss all submitted amendments and comments to the Grid Code prior to coming up with recommendations to amending the Grid Code. The Panel however has the right to treat an amendment as frivolous in accordance with the MR.

9.6 The Panel through TCN shall establish (and, where appropriate, revise from time to time) joint working arrangements with industry stakeholders or operators to facilitate the identification, coordination and implementation of change to their operations consequent on an amendment to the Grid Code in a full and timely manner. These working arrangements shall be such as to enable development and evaluation of proposed amendments to the Grid Code, how operators will proceed in a full and timely manner to changes to their operations consequent to an amendment to the Grid Code to be made and given effect wherever possible (subject to any necessary consent of the Nigerian Electricity Regulatory Commission) at the same time as such approved amendment is made and given effect.